

KENWOOD

Document Copyrights

Copyright 2006 by Kenwood Corporation. All rights reserved.

No part of this manual may be reproduced, translated, distributed, or transmitted in any form or by any means, electronic, mechanical, photocopying, recording, or otherwise, for any purpose without the prior written permission of Kenwood.

Disclaimer

While every precaution has been taken in the preparation of this manual, Kenwood assumes no responsibility for errors or omissions. Neither is any liability assumed for damages resulting from the use of the information contained herein. Kenwood reserves the right to make changes to any products herein at any time for improvement purposes.

文档版权信息

Kenwood Corporation 拥有版权 2006。保留所有权利。

未经 Kenwood 公司预先书面同意，无论出于何种目的，均不得以任何形式或任何方式包括电子、机械、影印、录音或其他方式复制、翻译、分发或传播本手册的任何部分。

免责声明

Kenwood 公司在准备本文档时已采取所有必要的预防措施，恕不对错误或疏漏承担任何责任，也不对因使用本文中所含的信息而导致的损害负责。Kenwood 公司保留出于改进的需要而随时对文中的产品信息做出更改的权利。

TKR-850

SERVICE MANUAL / 维修手册

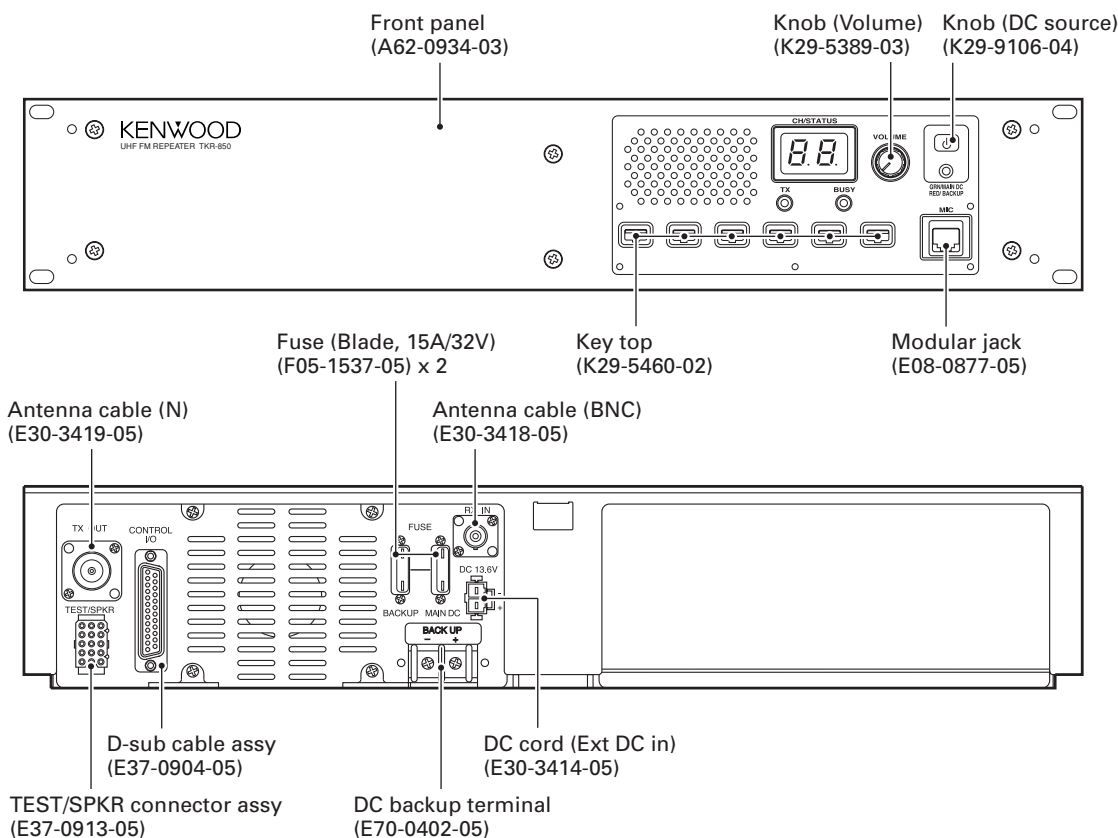
REVISED II / 修订版 II

KENWOOD

© 2004-11 在日本印刷
B51-8568-20 (N) 596

This service manual applies to products with 60800001 or subsequent serial numbers.
In terms of the products with the serial numbers earlier than 60800001, refer to the TKR-850 service manual as per part No. B51-8568-10 or B51-8676-00.

本维修手册适用于60800001或其后续序列号的产品。
有关比60800001早的序列号产品, 请参考编号为B51-8568-10和B51-8676-00的TKR-850维修手册。



CONTENTS

GENERAL	2	TERMINAL FUNCTION	65
SYSTEM SET-UP	3	BLOCK DIAGRAM	73
OPERATING FEATURES	4	INTERCONNECTION DIAGRAM	76
REALIGNMENT	5	PC BOARD	
INSTALLATION	8	FINAL UNIT (X45-374X-XX)	78
MODIFICATION	13	DISPLAY UNIT (X54-3330-21)	82
DISASSEMBLY FOR REPAIR	15	TX-RX UNIT (X57-696X-XX) (A/2)	86
CIRCUIT DESCRIPTION	16	TX-RX UNIT (X57-696X-XX) (B/2)	90
SEMICONDUCTOR DATA	26	RX VCO UNIT (X58-480X-XX)	94
COMPONENTS DESCRIPTION	31	TX VCO UNIT (X58-481X-XX)	95
PARTS LIST	34	SCHEMATIC DIAGRAM	96
EXPLODED VIEW	46	KES-5 (EXTERNAL SPEAKER)	109
PACKING	48	SPECIFICATIONS	110
ADJUSTMENT	49		

TKR-850

目 录

概 述	2	端子功能	65
系统体系	3	方 块 图	73
操作特性	4	总布线图	76
模式组合	5	PC板	
安 装	8	FINAL UNIT(X45-374X-XX)	78
改 装	13	DISPLAY UNIT(X54-3330-21)	82
维修时拆卸部件	15	TX-RX UNIT(X57-696X-XX) (A/2)	86
电路说明	16	TX-RX UNIT(X57-696X-XX) (B/2)	90
半导体数据	26	RX VCO UNIT(X58-480X-XX)	94
元件说明	31	TX VCO UNIT(X58-481X-XX)	95
零 件 表	34	原 理 图	96
部件分解图	46	KES-5 (外部扬声器)	109
包 装	48	规 格	111
调 整	50		

Service Manual List

Title	Parts number	Remarks	Destination	Final unit number	TX-RX unit number	Display unit number
TKR-850	B51-8568-00		C, C3	X45-3630-10	X57-6270-10	X54-3330-20
TKR-850	B51-8568-10	REVISED	C, C3, C6	X45-363X-XX	X57-627X-XX	X54-3330-20
TKR-850	B51-8676-00	SUPPLEMENT II	C, C3, C6	X45-374X-XX	-	-
TKR-850	B51-8568-20 (This service manual)	REVISED II	C, C3, C6	X45-374X-XX	X57-696X-XX	X54-3330-21

GENERAL / 概述

INTRODUCTION

SCOPE OF THIS MANUAL

This manual is intended for use by experienced technicians familiar with similar types of commercial grade communications equipment. It contains all required service information for the equipment and is current as of this publication date. Changes which may occur after publication are covered by either Service Bulletins or Manual Revisions, which are issued as required.

ORDERING REPLACEMENT PARTS

When ordering replacement parts or equipment information, the full part identification number should be included. This applies to all parts: components, kits, and chassis. If the part number is not known, include the chassis or kit number of which it is a part and a sufficient description of the required component, for proper identification.

PERSONAL SAFETY

The following precautions are recommended for personal safety:

- DO NOT transmit until all RF connectors are secure and any open connectors are properly terminated.
- SHUT OFF this equipment when near electrical blasting caps or while in an explosive atmosphere.
- This equipment should be serviced by only qualified technicians.

引言

本手册的范围

本手册是提供给熟悉通信专业并且具有维修经验的技术人员使用的。它包括了维修该设备所需要的全部资料和现行出版日期。在出版后可能发生变动,如果需要,可以参照《维修通报》或《手册修订本》进行补充。

替换零件的订购

当订购替换零件或设备资料时,应注意完整的零件识别号码。所有的零件均有识别号码:元件,组件或机壳。如果不知道零件的号码,为了正确地识别,必须注明此元件所属的机壳或组件的号码,并对元件进行充分的说明。

个人安全

为了个人的安全,请注意下列事项:

- 在没有认真核实所有射频插头之前或有任何一个脱开的插头没有连接到相应端口上的情况下均不要发射。
- 在电爆管附近或在易燃性气体环境中,必须关闭电源,不要操作本设备。
- 本设备只应该由有资格的技术人员进行维修。

GENERAL / 概述

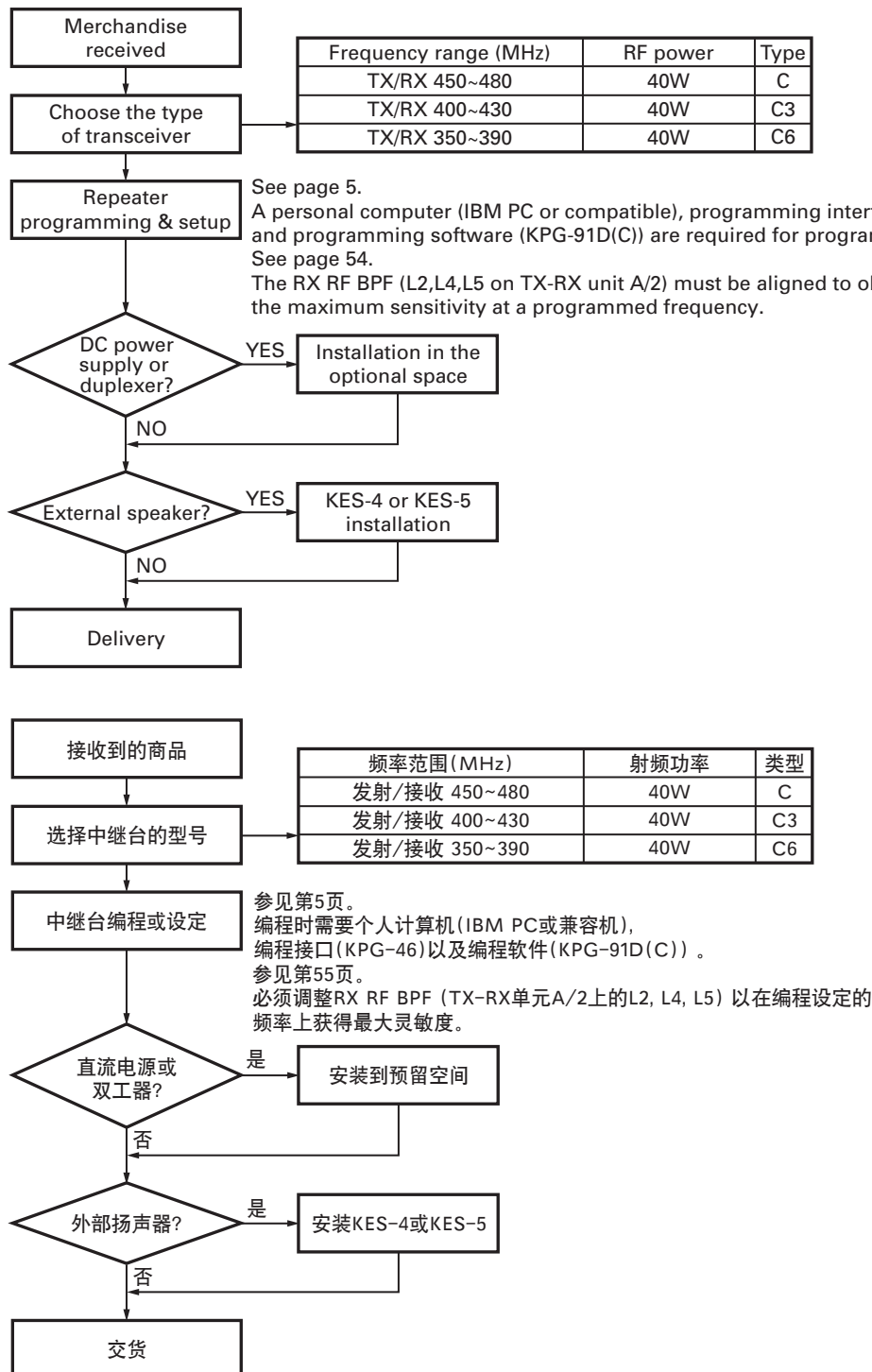
SERVICE

This radio is designed for easy servicing. Refer to the schematic diagrams, printed circuit board views, and alignment procedures contained in this manual.

维修服务

为了便于维修本设备,建立了完整的维修服务体系,提供了包括原理图,印刷电路板图和调整步骤在内的资料供参考。

SYSTEM SET-UP / 系统体系



OPERATING FEATURES / 操作特性

1. Two 7-segment LED displays

1. 双7段LED显示器

- Channel display (1~16) : While operating normally in user mode.

- 信道显示 (1 ~ 16) : 以用户模式为主运行时。

1 16

- When the displayed channel is contained in scan sequence, the right side decimal point is displayed.

- 显示的信道包含在扫描顺序中时, 显示右侧的小数点。

2.

- When the displayed channel is the priority channel, the left side decimal point is displayed.

- 显示的信道为优先信道时, 显示左侧的小数点。

.3.

- "PC" is displayed while in PC mode.

- 在PC模式下时显示 "PC"。

PC

- "PG" is displayed while in firmware programming mode.

2 decimal points displayed = 115,200bps

1 decimal point displayed = 57,600bps

No decimal = 38,400bps

- 在固件编程模式下时显示 "PG"。

显示2个小数点 = 115,200bps

显示1个小数点 = 57,600bps

无小数点 = 38,400bps

PG PG

- "E1" is displayed when FPU data is not written.

- FPU数据没有写入时显示 "E1"。

E1

- "E2" is displayed when the channel data is not written.

- 信道数据没有写入时显示 "E2"。

E2

- "E3" is displayed when PLL is unlocked.
Receiver PLL unlocked = BUSY LED blinks.
Transmitter PLL unlocked = TX LED blinks.

- PLL失锁时显示 "E3"。
接收机PLL失锁 = BUSY (占用) LED闪烁。
发射机PLL失锁 = TX (发射) LED闪烁。

E3

- "E4" is displayed when PTT is attempted on a channel number that has no frequency data programmed.

- 试图在未编程频率数据的信道号码按下PTT时显示 "E4"。

E4

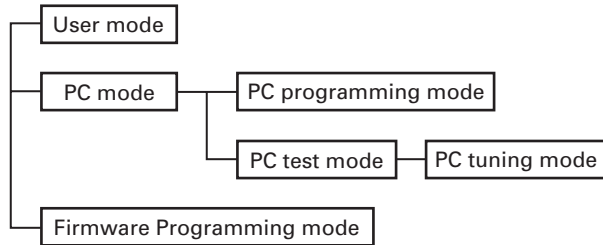
- "SC" is displayed while in scan mode.

- 在扫描模式下显示 "SC"。

SC

REALIGNMENT / 模式组合

1. Modes



Mode	Function
User mode	Use this mode for normal operation.
PC mode	Use this mode to make various settings by means of the FPU through the RS-232C port.
PC programming mode	Use to read and write frequency data and other features to and from the repeater.
PC test mode	Use to check the repeater using the PC. This feature is included in the FPU.
Firmware programming mode	Use when changing the firmware program of the flash memory.

2. How to Enter Each Mode

Mode	Operation
User mode	Power on.
PC mode	Received commands from PC.
Firmware Programming mode	[PF1] key + Power on (one second).

3. PC Mode

3-1. Preface

The TKR-850 repeater is programmed by using a personal computer, programming interface and KPG-91D(C) software.

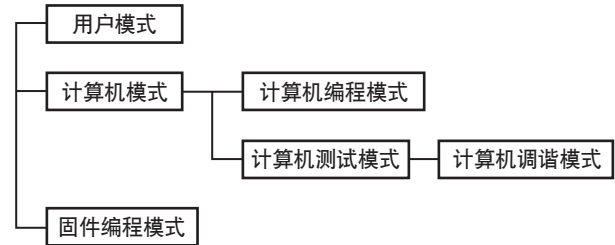
3-2. Connection Procedure

1. Connect the TKR-850 to the personal computer with the interface cable.
2. When power is applied, the user mode is entered immediately. When the PC sends a command, the repeater enters the PC mode and displays "PC" on the 7-segment LED. When data is being transmitted to the PC from the repeater, the TX LED flashes. The BUSY LED flashes when data from the PC is being received by the repeater.

Note :

- The data stored in the personal computer must match the model type, when it is written into the flash memory.
- Change the TKR-850 to PC mode, then attach the interface cable.

1. 模式



模式	功能
用户模式	一般使用。
计算机模式	使用外部写频器 (计算机) 通过RS-232C接口对通信机进行各种设定的模式。
计算机编程模式	用于阅读和写入频率数据以及其他功能。
计算机测试模式	用于使用计算机检测。此特性包括在FPU内。
固件编程模式	当改变FLASH ROM中操作主程序时使用。

2. 如何进入每一种模式

模式	操作
用户模式	接通电源
计算机模式	从计算机接收指令
固件编程模式	[PF1] + 接通电源 (1秒钟)

3. 计算机模式

3-1. 前言

TKR-850中继台使用计算机, 编程电缆 (KPG-46) 和编程软件 (KPG-91D(C)) 进行编程。

3-2. 连接步骤

1. 使用编程电缆将TKR-850与计算机连接。
2. 接通电源时立即进入用户模式。当计算机发出一个指令时, 中继台进入计算机模式, 并且在7段LED显示器上显示 "PC"。当中继台向计算机传送数据时, TX LED指示灯闪烁。当中继台接收来自计算机的数据时, BUSY LED指示灯闪烁。

注释 :

- 储存在计算机内的数据必须与写入到EEPROM的格式相匹配。
- 将TKR-850改变为计算机编程模式, 然后连接编程电缆。

REALIGNMENT / 模式组合

3-3. KPG-46 Description (PC Programming Interface Cable : Option)

The KPG-46 is required to interface the TKR-850 to the computer. It has a circuit in its D-sub connector (25-pin) case that converts the RS-232C logic level to the TTL level.

The KPG-46 connects the microphone connector of the TKR-850 to the computer's RS-232C serial port.

3-4. Programming Software Description

The KPG-91D(C) is the programming software for TKR-850 supplied on a CD-ROM. This software runs under Windows 98, ME, Windows 2000 or XP on an IBM-PC or compatible machine.

The data can be input to or read from TKR-850 and edited on the screen. The programmed or edited data can be printed out. It is also possible to tune the transceiver.

3-5. Programming With IBM PC

Data can be programmed into the flash memory in RS-232C format via the microphone connector.

3-3. KPG-46说明(计算机编程电缆:可选件)

KPG-46用于将TKR-850与计算机连接。在其D型副插座(25芯)中有一个电平转换电路,此电路可以把RS-232C逻辑电平转换为TTL电平。

KPG-46将TKR-850的话筒插座与计算机的RS-232C串行口连接。

3-4. 编程软件说明

KPG-91D(C) 是中继台TKR-850的编程软件。此软件的运行环境为IBM-PC机或兼容机的Windows 98, ME, Windows 2000或XP。

数据可以被输入到TKR-850中继台或从中继台中读取数据,并且在屏幕上进行编辑。已被编程或编辑的数据可以打印出来。也可以调整中继台的指标。

3-5. 使用IBM计算机编程

RS-232C格式的数据经由话筒插座输入到通信机的Flash Rom中。

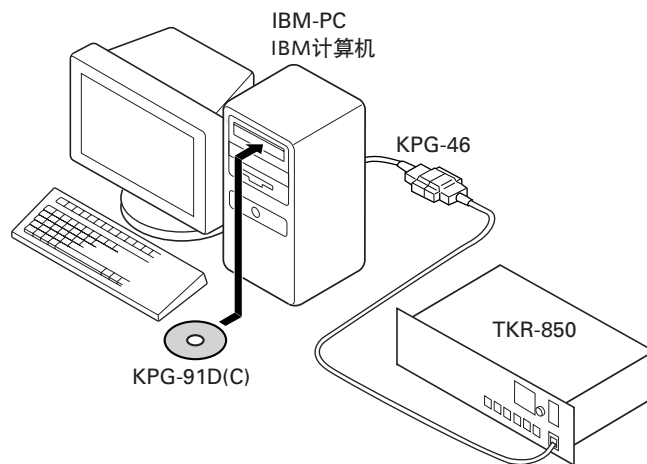


Fig. 1 / 图1

4. Firmware Programming Mode

4-1. Preface

The TKR-850 uses flash memory to allow it to be easily upgraded when new features are released in the future.

4-2. Connection Procedure

Connect the TKR-850 to the personal computer (IBM PC or compatible) with the interface cable (KPG-46). (Connection is the same as in the PC mode.)

Notes :

You can only program firmware from the 8-pin microphone connector on the front panel. Using the 25-pin logic interface on the rear panel will not work.

4. 固件编程模式

4-1. 前言

Flash Rom被安装在TKR-850上。当将来出现新功能时,允许TKR-850升级。

4-2. 连接步骤

使用编程电缆(KPG-46)将TKR-850与计算机(IBM计算机或兼容机)连接。(与计算机编程模式中的连接方法一样。)

注释:

只能通过前面板上的8芯话筒插座进行编程,无法使用后侧面板上的25芯逻辑接口。

REALIGNMENT / 模式组合

4-3. Programming

1. Start up the programming software (Fpro. exe).
2. Set the communications speed (normally, 115200 bps) and communications port in the configuration item.
3. Set the firmware to be updated by file name item.
4. Turn the TKR-850 power on with the [PF1] key held down. Hold the key down for one second until the 7-segment display changes to "P.G.". When "P.G." appears, release your finger from the key.
5. Check the connection between the TKR-850 and the personal computer, and make sure that the TKR-850 is in the program mode.
6. Press write button in the window. A window opens on the display to indicate progress of writing.
7. If writing ends successfully, the TX LED on the TKR-850 lights.
8. If you want to continue programming other TKR-850s, repeat steps 3 to 6.

Notes :

This mode cannot be entered if the firmware program mode is set to disable in the programming software (KPG-91D(C)).

4-4. Function

If you press the [PF1] key (front panel), both decimal points on the 7-segment display will disappear. The writing speed is 38400 bps (low-speed mode). If you press the [PF1] key again, the right hand decimal points will light. The writing speed is 57600 bps (middle-speed mode).

Note :

Normally, write in the high-speed mode (115200 bps).

4-3. 编程

1. 启动编程软件 (FPRO.exe)。
2. 在设置项目中设定通信速率 (通常为115200bps) 和通信端口。
3. 在文件名称项中选定新固件。
4. 在按住 [PF1] 键的同时接通TKR-850的电源。按住该键1秒钟直到7段显示器的显示成为 "P.G."。当 "P.G." 出现时, 松开按键。
5. 检查TKR-850与计算机之间的连接, 并且确认TKR-850处于编程模式。
6. 按下窗口中的写入按钮, 显示器上开启一个窗口并提示写入步骤。
7. 当成功写入数据后, TKR-850上的TX LED指示灯点亮。
8. 如果希望继续编程设置其他TKR-850, 重复步骤3到6。

注释 :

如果在编程软件 (KPG-91D(C)) 中固件编程模式设定为禁用, 则不能进入此模式。

4-4. 功能

如果按下 [PF1] 键 (前面板), 7段显示器上的两个小数点消失, 写入速率为38400bps (低速模式)。如果再按下 [PF1] 键, 右侧小数点点亮, 写入速率为57600bps (中速模式)。

注释 :

通常情况下在高速率模式中写入数据 (115200bps)。

1. External Power Supply Connection (Rear Connectors)

This unit has two external power supply connectors : Main DC and Backup.

If an external DC power supply is connected to the main DC connector and a backup battery is connected to the Backup connector at the same time, the DC power supply switches to the battery automatically if power failure occurs. Therefore, the operation of the repeater can be continued.

If the battery is used, but both the battery and power supply need not be connected (if an external switch is used or if only a solar battery is used), connect it to the Backup connector, not the Main DC connector. Current consumption can be reduced by approx. 120mA because the relay is not used.

If it is installed when the temperature at the repeater site is below freezing, check whether the switch (relay) works properly after installation.

2. Voice Scrambler

It operates only during base operation. The voice is not scrambled when it is repeated.

2-1. Modification

1) Remove R742 and R653 on the TX-RX unit (B/2) : control section.

2-2. Connection

1) The functions of pins of CN601 on the TX-RX unit (B/2) : control section are shown in the figure.
2) Join the CN601 connector to the voice scrambler board via the E37-0808-05 connector cable.

When the operation is checked in PC test mode after the modification, and the maximum deviation is adjusted, the voice from the local microphone is not modulated. In this case, remove the CN601 12-pin (PTO) cable and connect it to the land of the display unit (X54-333) from the voice scrambler. The voice from the local microphone can be modulated in PC test mode.

1. 外部电源的连接 (背面端子)

本机具有主DC和后备两个外部电源连接端子。

主DC端子连接外部DC电源, 后备端子连接后备电池, 两部分同时连接, 万一发生停电时, DC电源将自动切换到电池电源, 因此可以继续进行中继运行。

但是当即使在使用电池的情况下也没有必要进行两部分同时连接时 (如果已经在外部具备切换装置, 或者仅使用太阳能电池运行时等), 请将电源连接到后备端子, 而不要连接到主DC端子, 这样可以在运行中节省大约120mA的驱动继电器消费电流。

当中继器设置现场为零度以下环境时, 完成设置后, 应首先确认上述的切换 (继电器的动作) 是否正常工作, 然后开始使用。

2. 声音扰频器

仅在基本运行时动作。作为中继器使用时, 对中继的声音不施加扰频。

2-1. 修改

1) 取消TX-RX单元B/2 (控制部分) 的R742和R653。

2-2. 连接

1) TX-RX单元B/2 (控制部分) 上的CN601管脚的功能如图所示。
2) 使用E37-0808-05连接电缆将CN601连接器与声音扰频器板连接。

完成上述修改后, 在计算机测试模式下进行动作检查时, 对于最大偏差调整, 本机麦克风的声调制将无法进行。这时, 应拆除CN601 12管脚 (PTO) 的电缆, 从声音扰频器连接至显示单元 (X54-333) 的纹间。这样, 在计算机测试模式下也可以对来自本机麦克风的声进行调制。

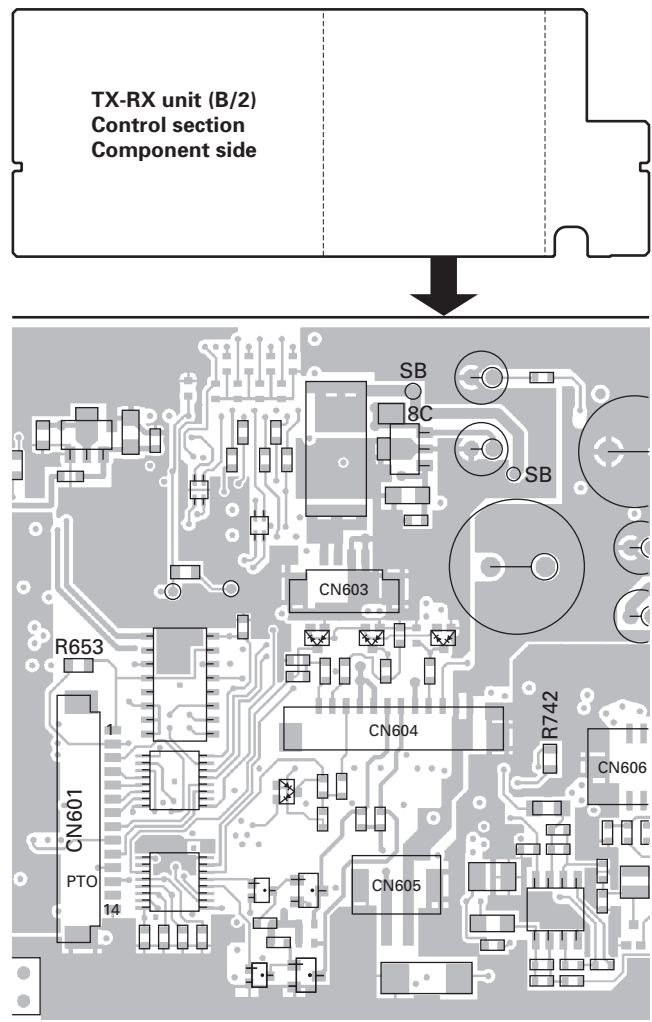


Fig. 1 / 图1

INSTALLATION / 安装

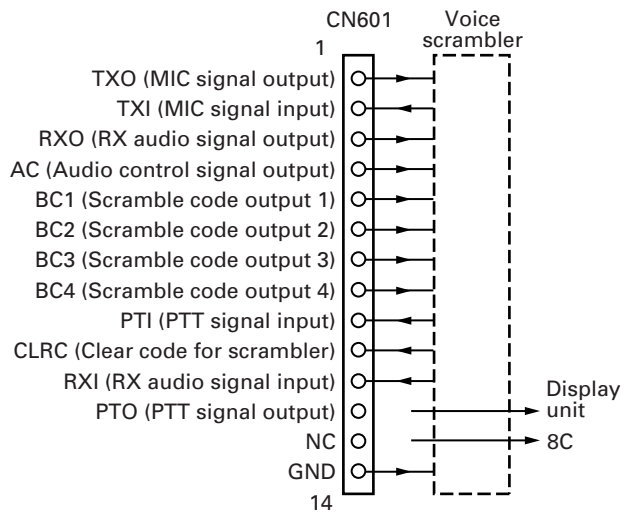


Fig. 2

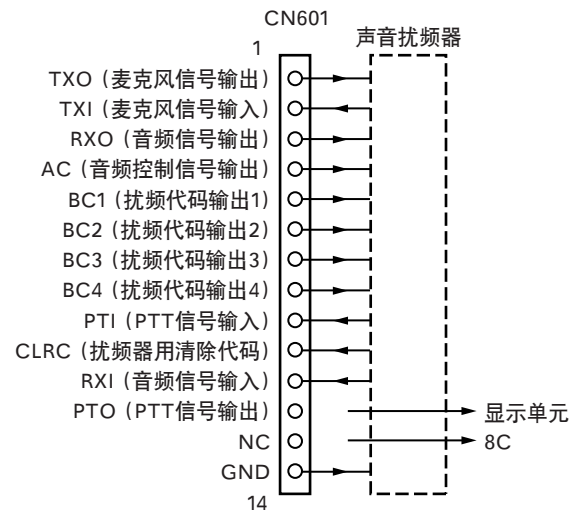


图2

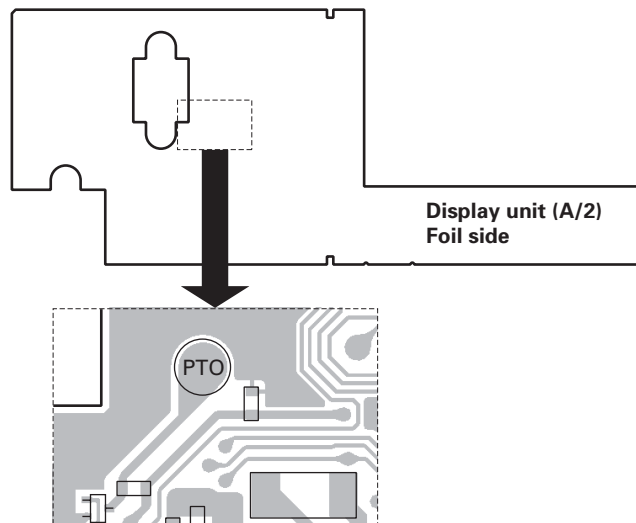


Fig. 3 / 图3

3. External Speaker (KES-4 or KES-5)

The TKR-850 has a internal built-in speaker (5W/8Ω), and the external speaker output from the TEST/SPKR connector (15-pin) on the rear of the radio is 4W/4Ω. Use external speaker KES-4 or KES-5.

3-1. Connection for the KES-4 or KES-5 With the TKR-850

■ **When taking the AF output from the TEST/SPKR connector (15-pin) on the rear of the radio**

The following tools are required for changing the connector.

3. 外部扬声器 (KES-4或KES-5)

TKR-850设有内置扬声器 (5W/8Ω) 和从本机后侧的TEST/SPKR连接器 (15插脚) 输出的外部扬声器 (4W/4Ω)。请使用KES-4或KES-5作为外部扬声器。

3-1. KES-4或KES-5与TKR-850的连接

■ **从本机后侧的TEST/SPKR连接器 (15插脚) 进行音频输出**

更换连接器时, 需要使用以下工具。

• Extracting tool

The following extracting tool is recommended :
Molex Inc. Order No. : J5800-002 (W05-0878-00)

1. Remove the connector with jumper from the external speaker connector on the rear panel of the radio. (Fig. 4-1)
Note : Save the jumper, which is required when the radio is used without the external speaker.
2. Remove the terminals with the jumper from the connector housing holes number 9 and 12 using the extracting tool.

Removing the jumper lead (Fig. 4-2)

- 1) Insert the extracting tool (J5800-002) into the connector while pushing the jumper lead in the direction of (a).
 - 2) Push the extracting tool into collapse the barbs of the crimp terminal.
 - 3) Pull out the lead while continuing to push the extracting tool in the direction (b).
3. Reinsert the terminal with the black and white stripe lead into hole number 12, and the terminal with the black lead into hole number 6. (Fig. 4-3)
 4. Attach the connector to the external speaker connector on the radio.

Note :

Relationship between TEST/SPKR connector (15-pin) connection and speaker output.

When pins 9 and 12 are shorted : Built-in internal speaker is used.

When pins 9 and 12 are open and output is from pins 6 and 12 : KES-4 or KES-5 is used.

● 拆卸工具

建议使用以下拆卸工具 :
Molex Inc. 订货编号 : J5800-002 (W05-0878-00)

1. 从本机后侧面板的外部扬声器连接器上拆下连接器和跳接器 (图4-1)。
注 : 请保存好跳接器以备本机不连接外部扬声器时使用。
2. 使用拆卸工具从连接器外壳的9号和12号孔中拆下端子。
拆下跳接器导线 (图4-2)
 - 1) 向 (a) 方向推跳接器导线, 将拆卸工具 (J5800-002) 插入连接器。
 - 2) 将拆卸工具压入解除压接端子的倒钩。
 - 3) 在继续向 (b) 方向推拆卸工具的同时拉出导线。
3. 将黑白条纹的导线重新插入端子的12号孔, 将黑色导线重新插入6号孔。(图4-3)。
4. 将连接器与本机的外部扬声器插座连接。

注 :

TEST/SPKR连接器 (15插脚) 的连接与扬声器输出的关系。
插脚9与12短路时, 使用内置扬声器。
插脚9与12开路, 并且从插脚6和12输出时 : 使用KES-4或KES-5。

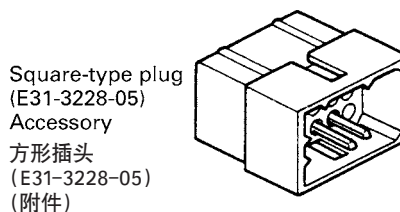


Fig. 4-1 / 图4-1

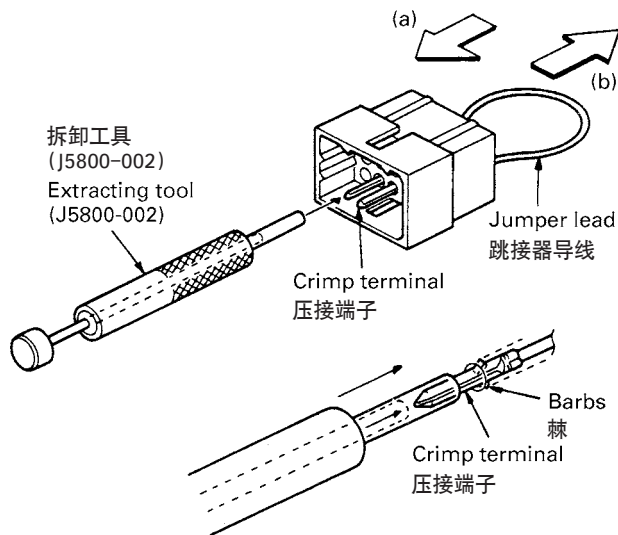


Fig. 4-2 / 图4-2

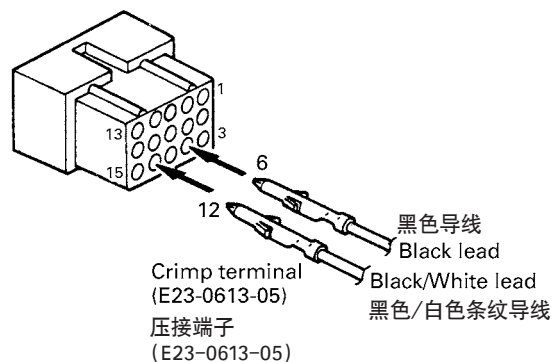


Fig. 4-3 / 图4-3

INSTALLATION / 安装

4. Accessory Cabinet

You can install optional accessories, such as a DC power supply or duplexers in the accessory cabinet.

1. Place the optional accessory in the cabinet as shown below.
2. If necessary, attach cushions (G13-1801-04 and/or G13-1802-04) to the top plate (J21-8402-04) in order to adjust the space between the cabinet and the top plate. Then, insert the 3 tabs of the plate into the slots in the side of the cabinet. High, middle, or low positions are available. To affix the plate, inset and tighten 2 screws on the other side of the plate.

You can also flip the top plate upside-down to adjust a height of the cabinet space.

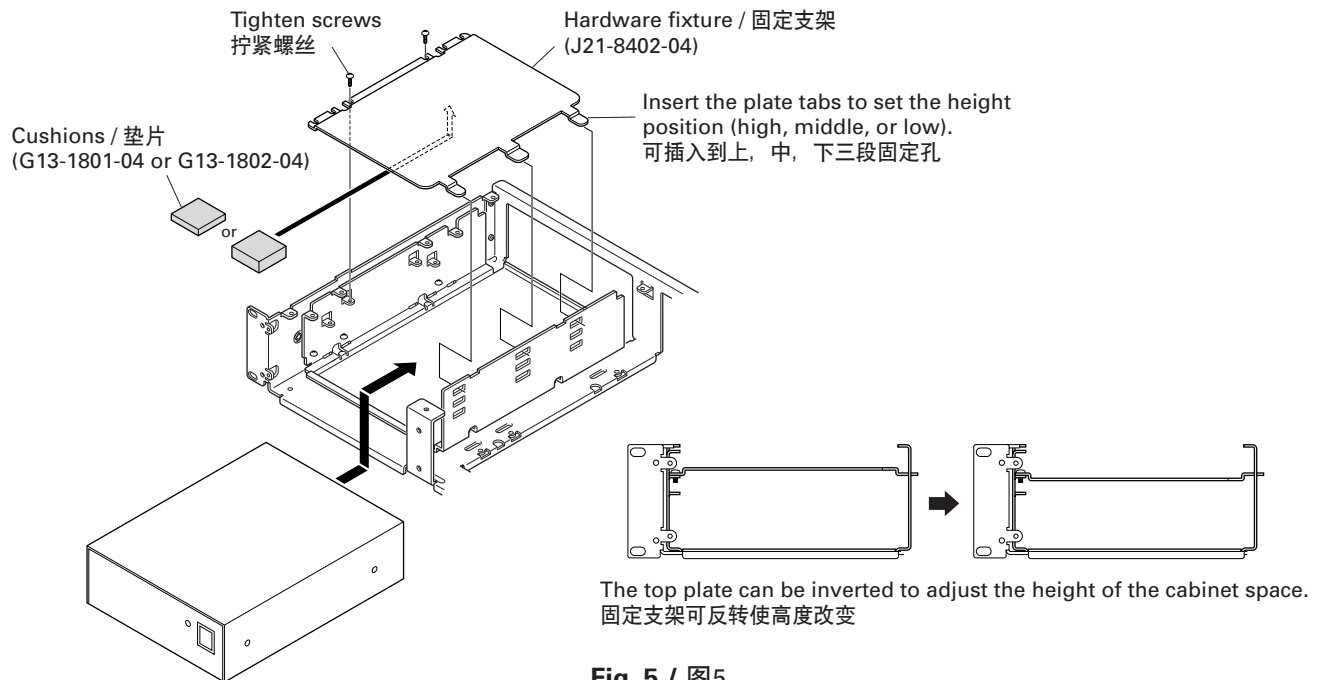


Fig. 5 / 图5

5. Key Cover

To avoid accidentally pressing the keys, you can install the key cover.

1. Install and fix the key protector using the 5 supplied screws (N35-3006-45).

5. 前面板盖

中继台设置完后, 为防止他人无意中按功能键, 建议安装前面板盖。

1. 使用附属螺丝5个, 按照图示安装前面板盖。

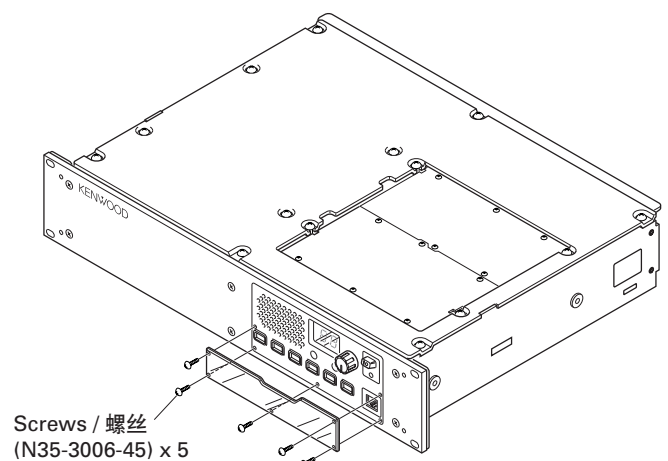


Fig. 6 / 图6

INSTALLATION / 安装

6. Desktop Repeater

When you use the repeater on the desktop, attach the 4 spacers to the base of the repeater as shown in figure. With these spacers attached, the front panel will not touch the desk surface.

6. 在桌上使用的场合

在桌上使用时,按照图所示安装支脚,然后放置于桌上。

Pegs

Firmly press these pegs (J59-0302-05) through the spacers to affix them to the repeater.

螺钉

请用力按压螺钉 (J59-0302-05) 穿过垫片将其固定到中继台上。

Peel off the backing paper to attach these spacers (J02-0492-04).

撕下衬纸附上垫片 (J02-0492-04)。

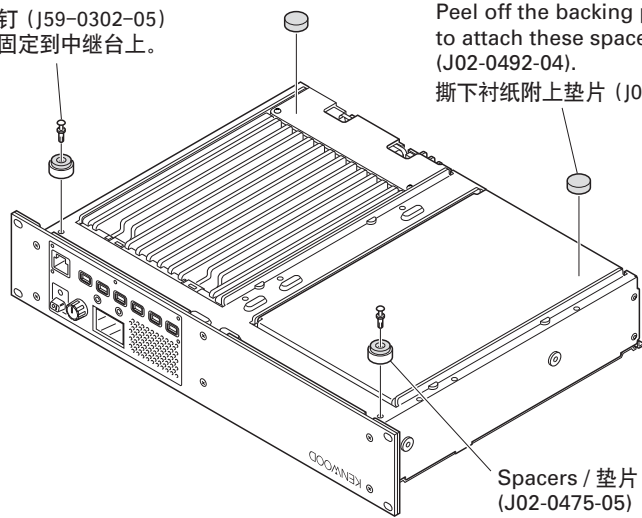


Fig. 7 / 图7

7. Installing Name Plates

Punch out the name plate card. Then insert the plates onto the relative function keys.

You can reconfigure the name plates at any time.

7. 功能键功能表示贴片的使用方法

把想使用的贴片取下,按入按键的嵌沟内。

根据设定的按键自由使用。

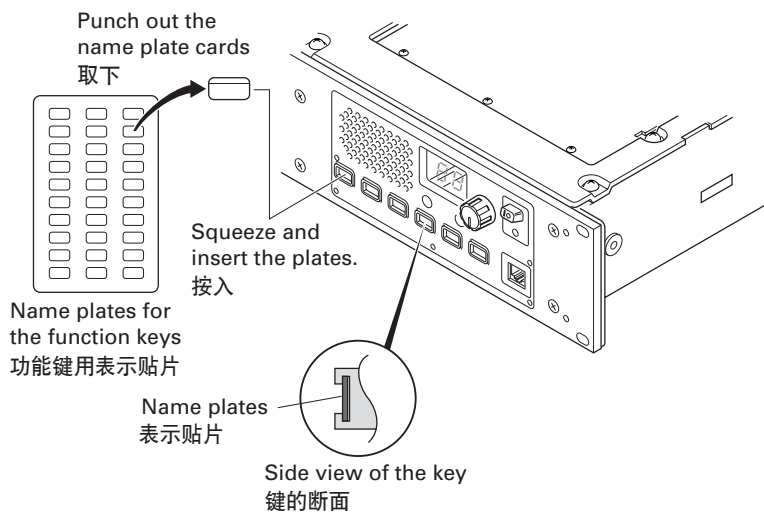


Fig. 8 / 图8

MODIFICATION / 改装

1. DC Source Switch

To prevent the power supply from turning off due to misoperation of the DC source switch on the front panel or accidents (tampering) after installation, the main unit can be kept on regardless of the on/off of the DC source switch on the front panel.

Short the PSW land near K1 relay by soldering.

1. DC电源开关

本机设置后, 为了防止对前面板的DC电源发生错误操作、以及意外(乱动)等产生本机电源切断等问题, 可以事先使得本机的电源始终接通, 而与前面板的DC电源开关的ON/OFF位置无关。

将在继电器侧面的PSW的纹间使用锡焊短路。

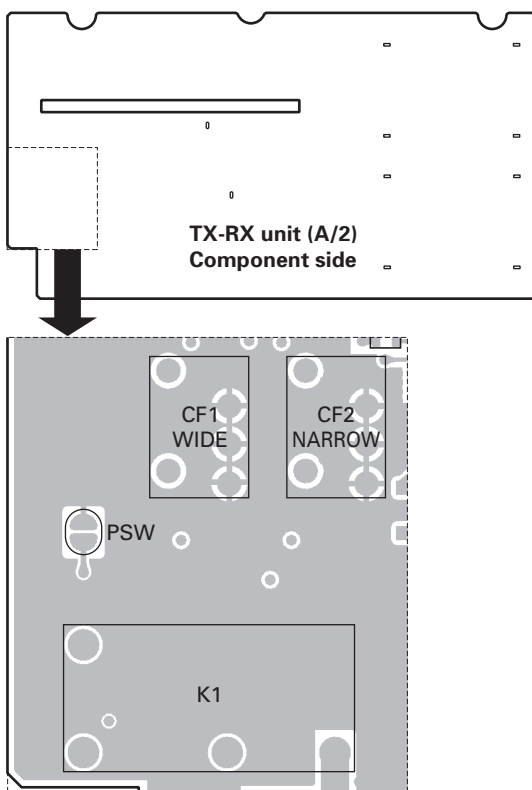


Fig. 1 / 图1

2. Trickle Charge for Backup Battery

If the external DC power supply is connected to the Main DC connector and a backup battery (12V rechargeable type) is connected to the Backup connector at the same time, the battery can be trickle-charged from the external DC power supply with a maximum current of 0.5A.

Short the CHARGE land near R61.

- When the DC power supply is connected after the modification, DC voltage is output to the Backup connector. Be careful during setup.
- When the backup battery is used for a long time, remove the battery from the repeater and recharge it because the trickle charge is not sufficient for recharging a completely discharged battery.

2. 后备电池的涓流充电

主DC端子连接外部DC电源, 并且后备端子连接后备电池(12V充电电池)时, 可以从外部DC电源对电池进行最大为0.5A的涓流充电。

将在R61侧面的充电纹间使用锡焊短路。

注意：

- 为了确保安全, 应先拆下DC电源和电池, 然后进行改装。
- 完成本改装后, 连接DC电源时DC电压将向后备端子输出, 因此请在设定时注意。
- 使用后备电池进行长期间运行之后, 应务必将电池从中继器上取出, 对电池进行单独充电。因为涓流充电无法对完全放电的电池进行充分的充电。

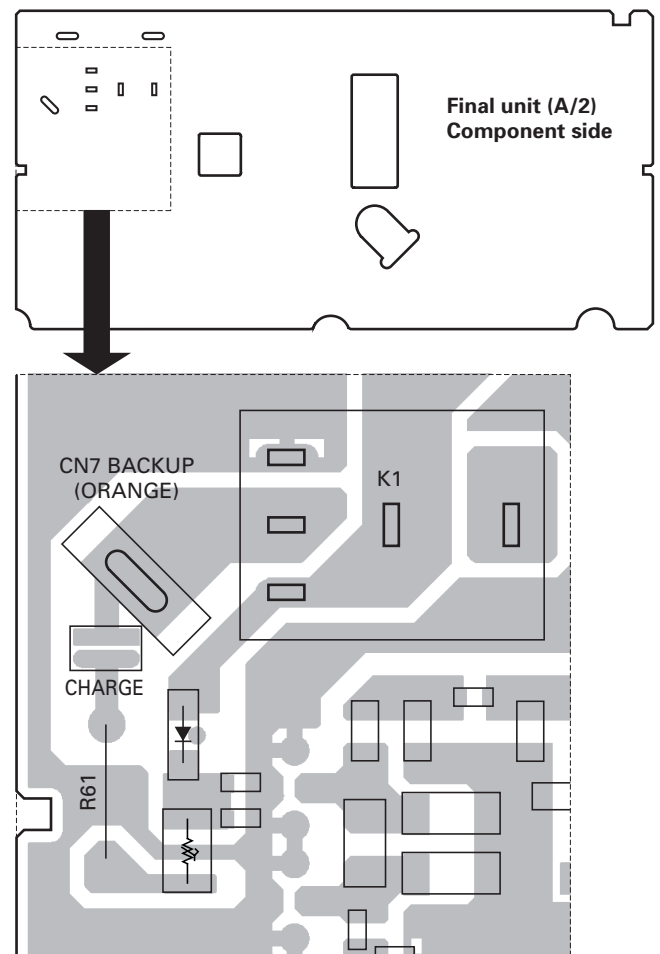


Fig. 2 / 图2

Notes :

- Make this modification after removing the DC power supply and battery for safety.

3. Single Antenna

The TKR-850 can be used as a base station by sharing an external antenna connector for both transmitting and receiving data.

3-1. Modification

1. Change the installation position of C81 and C160 of the final unit using a soldering iron.

3. 单一天线

通过共用一个外置天线连接器来发射和接收数据, TKR-850可以用作基地台。

3-1. 改装

1. 使用烙铁改变末级单元C81和C160的安装位置。

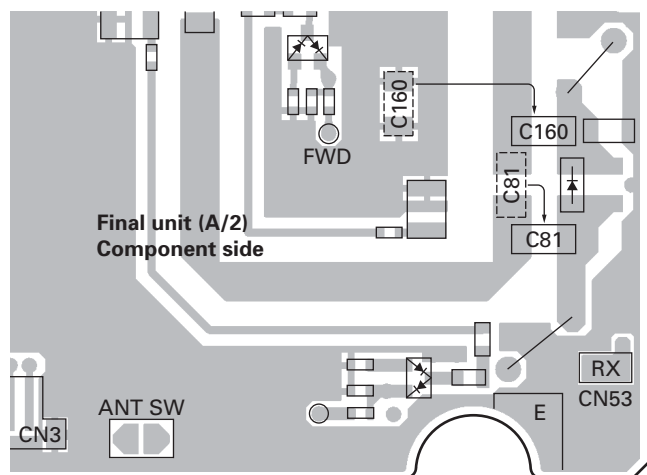


Fig. 3 / 图3

2. Short-circuit the printed pattern of ANT SW near the CN3 connector by soldering.
3. Disconnect the pin connector from CN18 of the TX-RX unit.
Remove the two screws used for securing the BNC connector on the back panel of the unit. Detach the antenna cable assy. (E30-3418-05)
4. Cut off the coaxial cable of the removed antenna cable on the BNC connector side.
Strip off the insulation of the cut-off coaxial cable to prepare it to be soldered.

2. 将在CN3侧面的ANT SW的纹间使用锡焊短路。
3. 从TX-RX单元的CN18断开管脚连接器。
取下机器后面板上用于固定BNC连接器的两颗螺钉。拆下天线电缆组件。(E30-3418-05)
4. 切断拆下的天线电缆组件BNC连接器侧的同轴电缆。
剥去切断的同轴电缆的绝缘层为焊接做好准备。

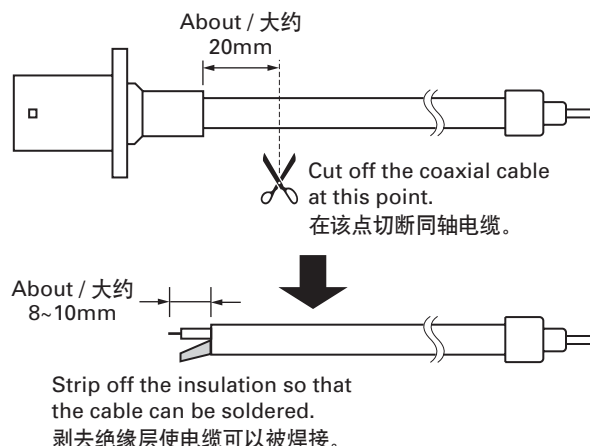


Fig. 4 / 图4

3-2. Connection

1. Solder the prepared coaxial cable to the final unit.
2. Connect the pin connector of the coaxial cable to CN18 of the TX-RX unit.

3-2. 连接

1. 将准备好的同轴电缆焊接到末级单元。
2. 将同轴电缆的管脚连接器连接到TX-RX单元的CN18。

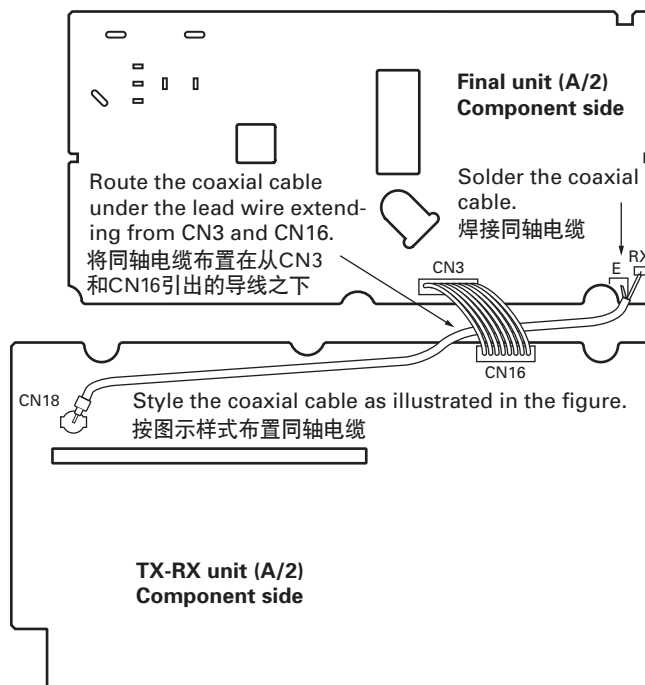


Fig. 5 / 图5

3-3. Setting the FPU

Set the channel to be used as "Simplex" using the FPU.

3-3. FPU的设置

利用FPU将信道设定为"Simplex" (单工)。

DISASSEMBLY FOR REPAIR / 维修时拆卸部件

1. How to Remove the Panel Assy (ABS)

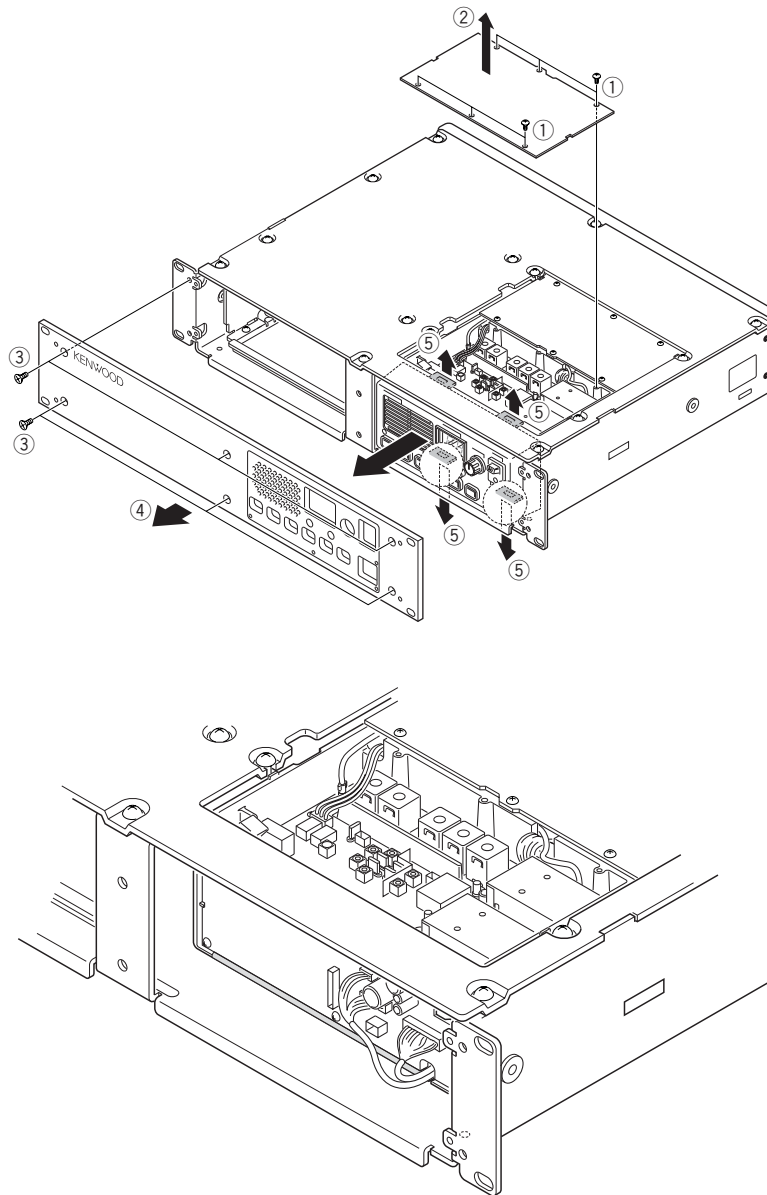
Note : You can remove the panel assembly (ABS) without removing the top panel (A62-0840-03).

1. To remove panel (TX-RX, ②), loose 6 screws (①).
2. To remove panel assembly (Front, ④), loose 6 screws (③).
3. The panel assembly (ABS) is security fastened by 4 tabs (⑤) on top and bottom. You can remove the panel assembly by pulling to front while you are pulling up the tabs.

1. 怎样拆卸前面板 (ABS)

注意 : 你可以拆下前面板 (ABS) 使之离开控制面板 (A62-0840-03)。

1. 拆除外壳 (TX-RX, ②), 卸下6个螺丝 (①)。
2. 拆除前面板 (前面板, ④), 卸下6个螺丝 (③)。
3. 在前面板的上部和下部, 有4个锁扣 (⑤), 可以在拆卸推进或拉出时锁定。



CIRCUIT DESCRIPTION / 电路说明

1. Outline

The TKR-850 is a UHF FM repeater designed to operate in the frequency range of 350 to 480MHz.

The unit consists of receiver, transmitter, phase-locked loop (PLL) frequency synthesizer, and control circuits.

2. Receiver Circuit

The receiver is double conversion super-heterodyne, designed to operate in the frequency range of 450 to 480MHz (C), 400 to 430MHz (C3) or 350 to 390MHz (C6).

The receiver circuit located in TX-RX unit (X57-696 A/2) consists of the following : 2-1 front-end circuit, 2-2 first mixer, 2-3 IF amplifier circuit, 2-4 audio amplifier circuit, and 2-5 squelch circuit.

2-1. Front-end Circuit

The front-end circuit consists of BPF L2, RF amplifier Q1, and BPF L4/L5. The helical BPF covers frequency ranges 450 to 480MHz (C), 400 to 430MHz (C3), 350 to 390MHz (C6), with a passband of 5.0MHz (C) or 3.0MHz (C3,C6).

The BPF L4/L5 attenuates the unwanted signals, and sends only the necessary signal to the first mixer DBM A1.

1. 概要

TKR-850是UHF调频中继台,在350至480MHz的频率范围内工作。

该单元由接收机,发射机,锁相环(PLL)频率合成器和控制电路构成。

2. 接收机电路

本接收部分为二次变频超外差式接收机,在450至480MHz (C),在400至430MHz (C3),在350至390MHz (C6) 的频率范围内工作。接收机的电路设在TX-RX单元 (X57-696 A/2) 中,由以下部分构成: 2-1 前置电路,2-2 第一混频器,2-3 中频放大电路,2-4 音频放大电路以及2-5 静噪电路。

2-1. 前置电路

前置电路由BPF L2, RF放大器Q1和BPF L4/L5构成。螺旋BPF的频率带宽为5.0MHz (C) 或3.0MHz (C3, C6),并且在频率范围为450至480MHz (C), 400至430MHz (C3), 350至390MHz (C6) 内移动。

BPF L4/L5可衰减不需要的信号,并且仅向第一混频器DBM A1送出需要的信号。

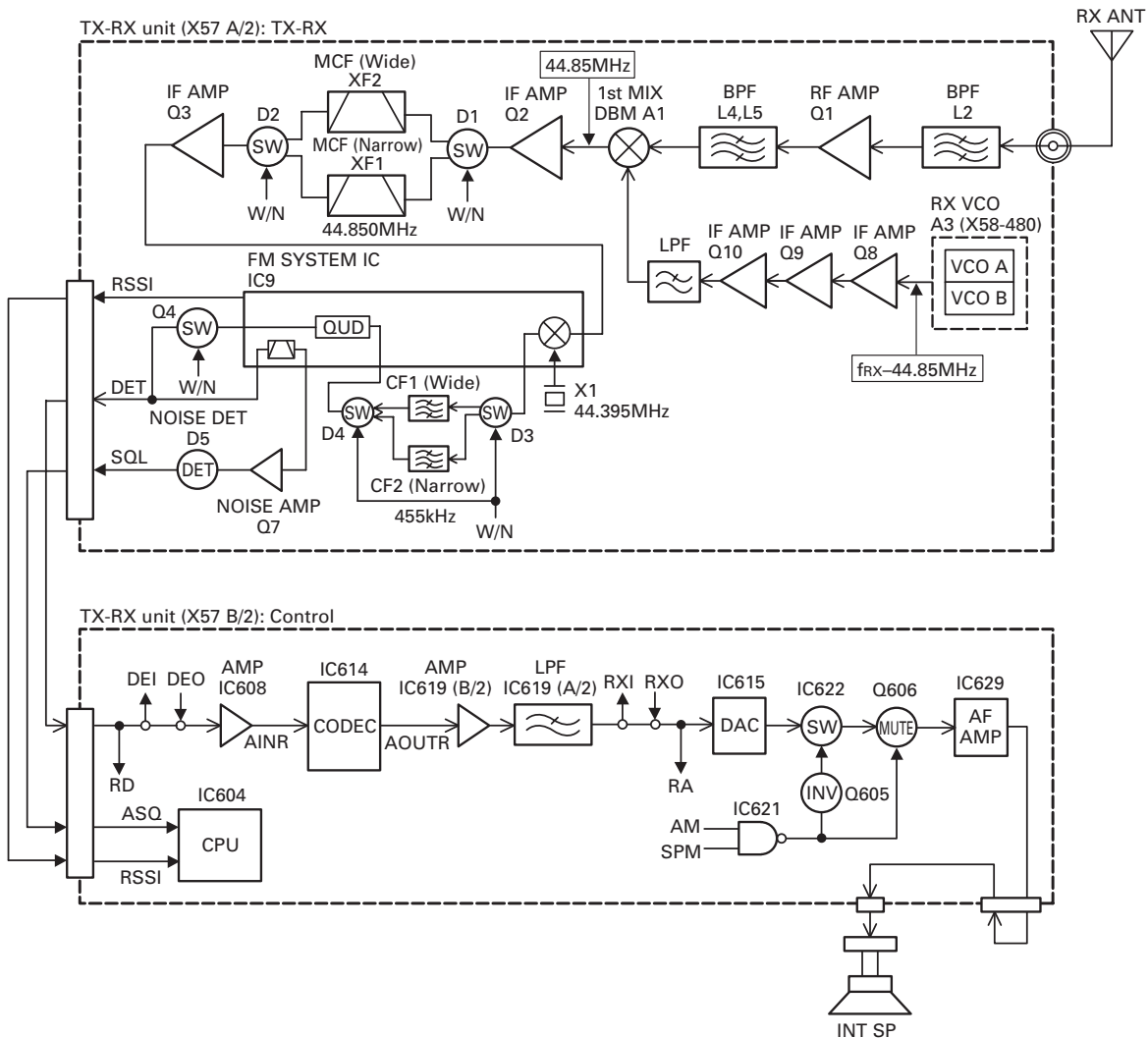


Fig. 1 Receiver circuit / 图1 接收机电路

CIRCUIT DESCRIPTION / 电路说明

2-2. First Mixer

The signal from the BPF is heterodyned with the first local oscillator signal from the PLL frequency synthesizer circuit at the first mixer DBM (A1) to become a 44.85MHz first intermediate frequency (IF) signal. The first IF signal is fed through two monolithic crystal filters (XF2; Wide, XF1; Narrow) to further remove spurious signals.

2-3. IF Amplifier

The first IF signal is amplified by Q2 and Q3, and then enters IC9 (FM system IC). The signal is heterodyned again with a second local oscillator signal (44.395MHz) with in IC9 to become a 455kHz second IF signal. The second IF signal is fed through a 455kHz ceramic filter, CF1 (Wide), CF2 (Narrow) to further eliminate unwanted signal, and the quadrature detection circuit FM-detects the signal to produce a base-band signal and output it from pin 11.

2-4. Audio Amplifier

The audio amplifier circuit is located in control section of TX-RX unit (X57-696 B/2). The recovered audio signal obtained from IC9 is amplified by IC608, input to the AINR terminal of CODEC IC (IC614), and audio processed by DSP (IC618).

The processed audio signal from AOUTR terminal of IC614 is amplified by IC619 (B/2) to a sufficient level, anti-aliasing filtered by IC619 (A/2). The audio signal goes to an electronic volume (IC615) V3/V4, to the input of multiplexer IC (IC622), and is amplified to drive a loudspeaker by an audio power amplifier (IC629). The 4W audio output can be provided to external 4 ohms speaker through the 15-pin test connector "SPO, SPG" on the rear panel.

2-5. Squelch Circuit

The output signal from IC9 enters FM IC again, then passed through a band-pass filter.

The noise component output from IC9 is amplified by Q7 and rectified by D5 to produce a DC Voltage corresponding to the noise level. The DC voltage is sent to the analog port of the CPU (IC604).

IC9 outputs a DC voltage (RSSI) corresponding to the input of the IF amplifier.

3. Transmitter Circuit

The transmitter circuit consists of the following circuits : 3-1 microphone circuit, 3-2 modulation level adjustment circuit, 3-3 driver and final power amplifier circuit, 3-4 automatic power control circuit, 3-5 RF power down detect, and 3-6 fan action control circuit.

3-1. Microphone Circuit

The signal from the microphone is passed through AGC circuit located in display unit (X54-333), so that it does not saturate. This circuit consists of IC501, D501, D502, Q501, and Q502. The AGC is operated by controlling the + and - side levels of amplitude using the current obtained by positive and negative detection of the amplified audio signal. The audio signal goes to control section of TX-RX unit (X57-696 B/2) from display unit (X54-333).

2-2. 第一混频器

来自BPF的信号在第一混频器DBM (A1) 与来自PLL频率合成电路的第一本振信号进行外差混频,生成44.85MHz的第一中频(中频)信号。第一中频信号通过两个单晶体滤波器(XF2:宽, XF1:窄),进一步滤除干扰信号。

2-3. 中频放大器

第一中频信号由Q2和Q3放大,然后进入IC9(FM系统IC)。信号再次与第二本机振荡器信号(44.395MHz)在IC9中进行外差混频,生成455kHz的第二中频信号。第二中频信号通过455kHz陶瓷滤波器(CF1:宽, CF2:窄),进一步滤除干扰信号,并且由正交检波电路进行FM信号检波,产生基带信号,最后从第11管脚输出。

2-4. 音频放大器

音频放大器电路设置在TX-RX单元(X57-696 B/2)的控制部分。来自IC9的接收音频信号经过IC608放大,然后输入到CODEC IC(IC614)的AINR端子,由DSP(IC618)处理音频信号。

来自IC614的AOUTR端子的处理后的音频信号由IC619(B/2)放大至足够的电平,由IC619(A/2)进行抗混叠滤波。音频信号送入电子电位器(IC615)V3/V4,至多路转接器IC(IC622),并且经过音频功率放大器(IC629)放大驱动扬声器。4W的音频信号经过位于后面板上的15管脚试验连接器"SPO, SPG"向4欧姆的外接扬声器输出。

2-5. 静噪电路

来自IC9的输出信号再次进入FM IC,然后通过带通滤波器。

从IC9输出的噪声成分经过Q7放大,并且经过D5校正,形成对应噪声电平的直流电压。该直流电压被送到CPU(IC604)的模拟端口。

对应中频放大器的输入,IC9输出直流电压(RSSI)。

3. 发射机电路

发射机电路由以下电路组成:3-1 麦克风电路,3-2 调制电平调节电路,3-3 驱动器和末级功率放大电路,3-4 自动功率控制电路和发射机,3-5 RF功率下降检测电路和3-6 风扇动作控制电路。

3-1. 麦克风电路

来自麦克风的信号通过设置在DISPLAY单元(X54-333)中的AGC电路,因此不会发生饱和。该电路由IC501, D501, D502, Q501和Q502构成。使用对放大的音频信号的正,负检波获得的电流,控制振幅的+侧和-侧电平实现AGC的功能。音频信号从DISPLAY单元(X54-333)进入TX-RX单元(X57-696 B/2)的控制部分。

CIRCUIT DESCRIPTION / 电路说明

The transmit audio signal goes to the input of the multiplexer IC (IC605) for microphone muting. The audio signal is amplified by IC610, input to the AINL terminal of CODEC IC (IC614), and audio processed by DSP (IC618). The processed audio signal from the AOUTL terminal of IC614 is amplified by IC616 (A/2) to a sufficient level, anti-aliasing filtered by IC616 (B/2), and amplified by the summing amplifier IC611 (A/2) (A/2).

发射音频信号进入多路转接器IC (IC605) 用于麦克风静音。音频信号被IC610放大, 输入CODEC IC (IC614) 的AINL端子, 音频信号由DSP (IC618) 处理。来自IC614的AOUTL端子的处理后的音频信号被IC616 (A/2) 放大至足够的电平, 由IC616 (B/2) 进行抗混叠滤波, 然后由加法放大器IC611 (A/2) 放大。

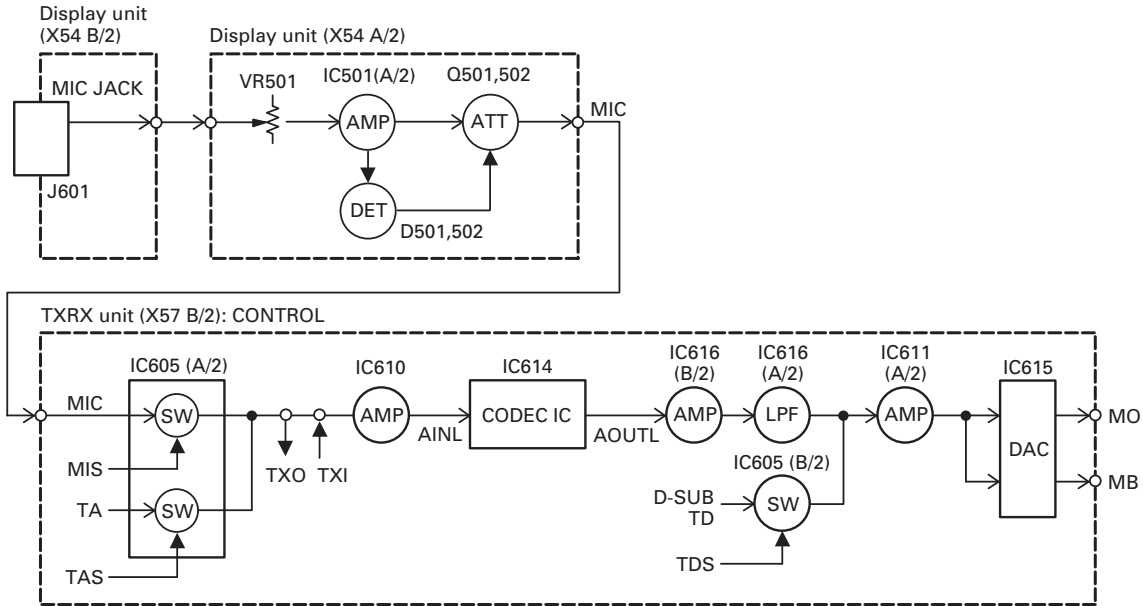


Fig. 2 Microphone circuit / 图2 麦克风电路

3-2. Modulation Level Adjustment Circuit

The output of the summing amplifier IC611 (A/2) is passed to an electronic volume (IC615) for maximum deviation adjustment before being applied to a varactor diode in the voltage controlled oscillator (VCO) A2 located in TX-RX unit (X57-696 A/2).

3-2. 调制电平调节电路

加法放大器IC611 (A/2) 的输出送入电位器 (IC615), 以便在送入设置在TX-RX单元 (X57-696 A/2)的压控振荡器 (VCO) A2 的变容二极管之前, 获得最大的偏差调节。

3-3. Driver and Final Power Amplifier Circuit

The transmit signal is generated by the TX VCO (A2), amplified by Q11, and sent to final unit (X45-374). This amplified signal is amplified by Q1, Q2, Q3 and Q4, and is passed to the FINAL stage. The RF power amplifier consists of MOS FET.

3-3. 驱动器和末级功率放大电路

TX VCO (A2) 产生发射信号, 经过Q11放大后, 送入末级单元 (X45-374)。该放大信号由Q1, Q2, Q3和Q4放大, 并且送入FINAL (末级) 部分。RF功率放大器由MOS FET构成。

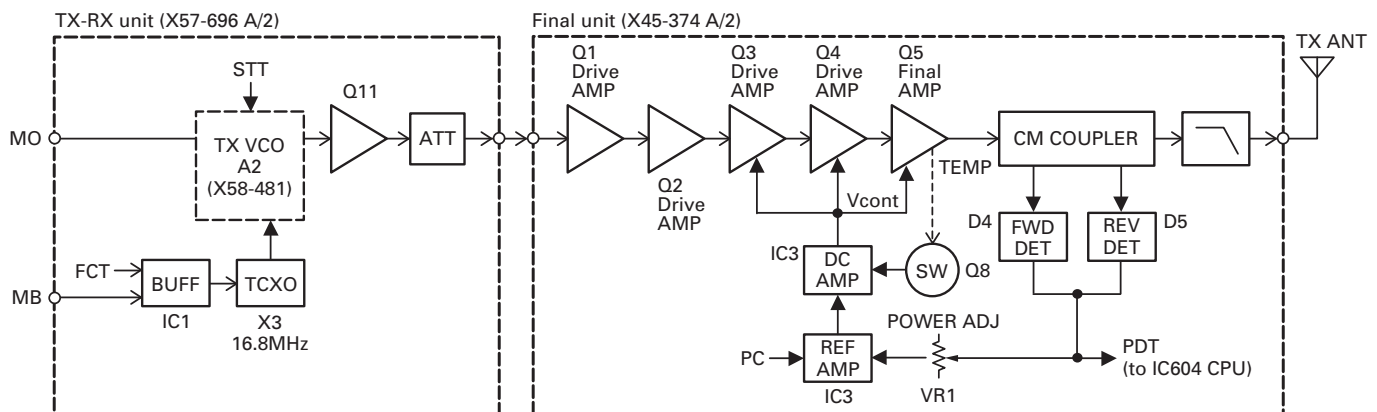


Fig. 3 Driver and final power amplifier circuit / 图3 驱动器和末级功率放大器电路

CIRCUIT DESCRIPTION / 电路说明

3-4. Automatic Power Control Circuit and Transmitter

The automatic power control (APC) circuit stabilizes the transmitter output power at a pre-determined level, and consists of forward/reverse power detector circuits, and switching transistor Q8. The forward/reverse power detector circuits detects forward RF power and reverse RF power to DC voltage, and consists of a CM coupling type detection circuit formed by a strip line, RF detector D4/D5, and DC amplifier IC3 (A/2).

The voltage comparator (IC3 B/2) compares the above detected voltage with a reference voltage, set using the micro-processor and IC6 located in the TX-RX unit. An APC voltage proportional to the difference between the sensed voltage and the reference voltage appears at the output of IC3. This output voltage controls the gate voltage for the drive amplifiers Q3 and Q4 and final amplifier Q5, which keeps the transmitter output power constant.

3-5. RF Power Down Detect

When the transmitter output power has dropped to or below the preset values (High Power : about 16W, Low Power : about 10W) in "RF Power Down Detect" adjustment, IC604 (CPU : X57-696) detects the drop in power and outputs a Low-level (default) signal to the AUX out port.

3-6. Fan Action Control Circuit

If fan action is set to "Temperature", the cooling fan is turned ON or OFF according to temperature.

If the ambient temperature of the final unit exceeds approx. 35°C, the output from the temperature detection IC1 changes from H to L. This signal is sent to the CPU (IC604) by Q602 in the TX-RX unit B/2 (control section), and the output from pin 13 (FAS) of IC7 in the TX-RX unit A/2 controlled by the CPU goes H.

This signal turns Q9 in the final unit ON to run the cooling fan. It has a hysteresis of approx. 2°C by IC1. If fan action is set to "Continuous", the fan operates continuously, but Q9 stays ON.

3-4. 自动功率控制电路和发射机

自动功率控制 (APC) 电路可以将发射输出功率稳定在预定的电平。该电路由发射/反射功率检波器电路和开关晶体管Q8构成。发射/反射功率检波器对发射的RF功率和反射的RF功率进行检测形成直流电压。该检波器由CM耦合型检波电路构成, 包括带状线, RF检波器D4/D5和直流放大器IC3 (A/2)。

电压比较器 (IC3 B/2) 将上述检波电压与参考电压进行比较, 使用设置在TX/RX单元中的微处理器和IC6进行设定。与检波电压和参考电压成正比的APC电压从IC3输出。该输出电压控制驱动放大器Q3和Q4和末级放大器Q5的栅电压, 保持发射功率的稳定。

3-5 RF功率下降检测电路

当发射机输出功率下降到或低于“RF Power Down Detect” (RF功率下降检测) 调整中的预设值 (高功率: 大约16W, 低功率: 大约10W) 时, IC604 (CPU: X57-696) 检测到功率的下降, 输出一个低电平 (默认) 信号到AUX输出端口。

3-6. 风扇动作控制电路

如果风扇动作设定为“Temperature” (温度), 将根据温度来控制冷却风扇的开或关。

如果末级单元周围环境温度超过约35°C, 温度探测器IC1的输出将从H改变到L。该信号由TX-RX单元B/2 (控制部分) 的Q602传送到CPU (IC604), 同时, 受CPU控制的TX-RX单元A/2中IC7的13 (FAS) 号引脚输出变为H。

该信号使得末级单元内的Q9接通, 冷却风扇运行。另外, IC1具有大约2°C的滞后特性。将风扇动作设定为连续时, 风扇“连续”动作, 这时Q9始终接通。

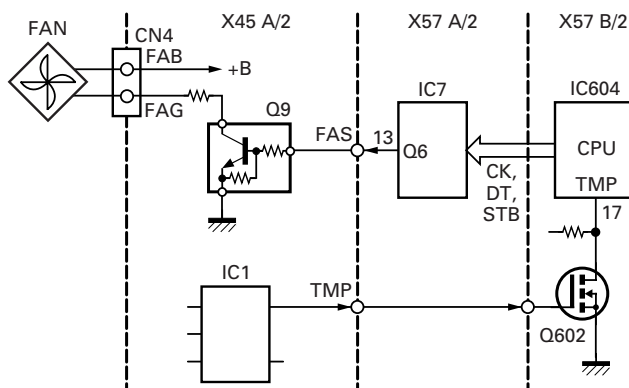
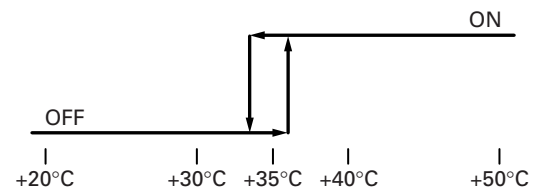


Fig. 4 Fan action control circuit / 图4 风扇动作控制电路

[Fan operation / 风扇动作]



4. PLL Frequency Synthesizer

The PLL frequency synthesizer circuit consists of the following circuits : 4-1 receiver PLL circuit, 4-2 transmitter PLL circuit, and 4-3 unlocked detector circuit.

4-1. Receiver PLL

The receiver PLL circuit is located in VCO unit A3 (X58-480) on TX-RX unit (X57-696 A/2), and consists of VCXO X2, VCO's (Q350 and Q351), a single-chip PLL IC IC300, buffer amplifier Q355, and high-frequency amplifier Q302.

The VCXO generates 16.8MHz. The frequency stability is within $\pm 1.5\text{ppm}$ (Temperature range of -30 to $+60^\circ\text{C}$). The frequency tuning of the VCXO is done to apply a voltage to pin 1 of the VCXO. The output of the VCXO is applied to pin 8 of the PLL IC through the pin 7 of the VCO.

The first local oscillator is a lower heterodyne local oscillator, and the VCO oscillator frequency is 405.15 to 435.15MHz (C), 355.15 to 385.15MHz (C3), 305.15 to 345.15MHz (C6).

The oscillator frequency is controlled by applying the VCO control voltage, obtained from the phase comparator to the varactor diodes.

4. PLL频率合成器

PLL频率合成器电路由以下电路构成：4-1 接收机PLL电路，4-2 发射机PLL电路和4-3 失锁检波器电路。

4-1. 接收机PLL

接收机PLL电路设置在TX-TR单元 (X57-696 A/2) 的VCO单元A3 (X58-480) 内, 由VCXO X2, VCO (Q350和Q351), 单片PLL IC IC300, 缓冲放大器Q355以及高频放大器Q302构成。

VCXO产生16.8MHz频率。该频率的稳定性在 $\pm 1.5\text{ppm}$ 范围 (温度范围： -30 至 $+60^\circ\text{C}$)。VCXO的频率调谐由向VCXO的引脚1施加的电压控制。VCXO的输出经过VCO的引脚7送至PLL IC的引脚8。

第一本振是下部外差本机振荡器, VCO振荡器频率为405.150至435.15MHz (C), 355.15至385.15MHz (C3), 305.15至345.15 MHz (C6)。

振荡器的频率由向VCO提供的控制电压控制, 该控制电压从相位比较器获得, 送至变容二极管。

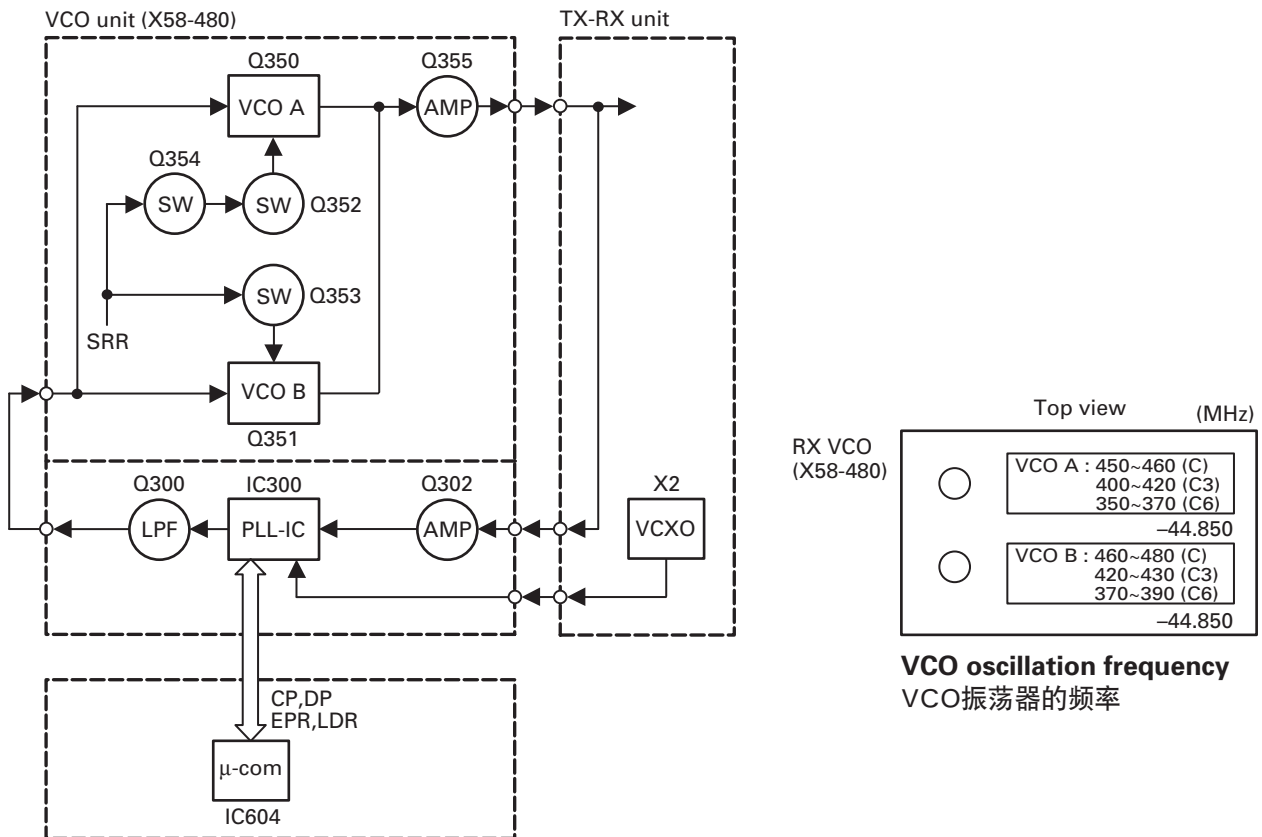


Fig. 5 Receiver PLL / 图5 接收机PLL

CIRCUIT DESCRIPTION / 电路说明

4-2. Transmitter PLL

The transmitter PLL circuit is located in VCO unit A2 (X58-481) on TX-RX unit (X57-696 A/2), and consists of VCXO X3, VCO's (Q350 : C type, Q351 : C3,C6 type), a single-chip PLL IC IC300, buffer amplifier Q355, and high-frequency amplifier Q302.

The VCXO generates 16.8MHz. The frequency stability is within ± 1.5 ppm (Temperature range of -30 to $+60^{\circ}\text{C}$). The frequency tuning and modulation of the VCXO are done to apply a voltage to pin 1 of the VCXO. The output of the VCXO is applied to pin 8 of the PLL IC through the pin 7 of the VCO.

The VCO oscillator frequency is 450.00 to 480.00MHz (C), 400.00 to 430.00MHz (C3), 350.00 to 390.00MHz (C6).

The oscillator frequency is controlled by applying the VCO control voltage, obtained from the phase comparator to the varactor diodes.

4-3. Unlock Detector Circuit

If a pulse signal appears at the LD pin of IC300, an unlock condition occurs, causing the voltage applied to the pin of the microprocessor to go low. The names of this pin are LDT for TX PLL and LDR for RX PLL. When the microprocessor detects this condition, the transmitter is disabled.

4-2. 发射机PLL

发射机PLL电路设置在TX-TR单元 (X57-696 A/2) 的VCO单元A2 (X58-481) 内,由VCXO X3,各VCO (Q350 : C或Q351 : C3, C6),单片PLL IC IC300,缓冲放大器Q355以及高频放大器Q302构成。

VCXO产生16.8MHz频率。该频率的稳定性在 ± 1.5 ppm范围(温度范围： -30 至 $+60^{\circ}\text{C}$)。VCXO的频率调谐和调制由向VCXO的管脚1提供的电压控制。VCXO的输出经过VCO的管脚7送至PLL IC的管脚8。

VCO振荡器频率为450.00至480.00MHz (C), 400.00至430.00MHz (C3), 350.00至390.00MHz (C6)。

振荡器的频率由向VCO提供的控制电压控制,该控制电压从相位比较器获得,送至变容二极管。

4-3. 失锁检波器电路

如果IC300的LD管脚出现脉冲信号,则发生失锁条件,使得施加在微处理器管脚的电压变成低状态。该管脚的名称对于TX PLL为LDT,对于RX PLL为LDR。当微处理器检测到该条件时,发射机为无法工作状态。

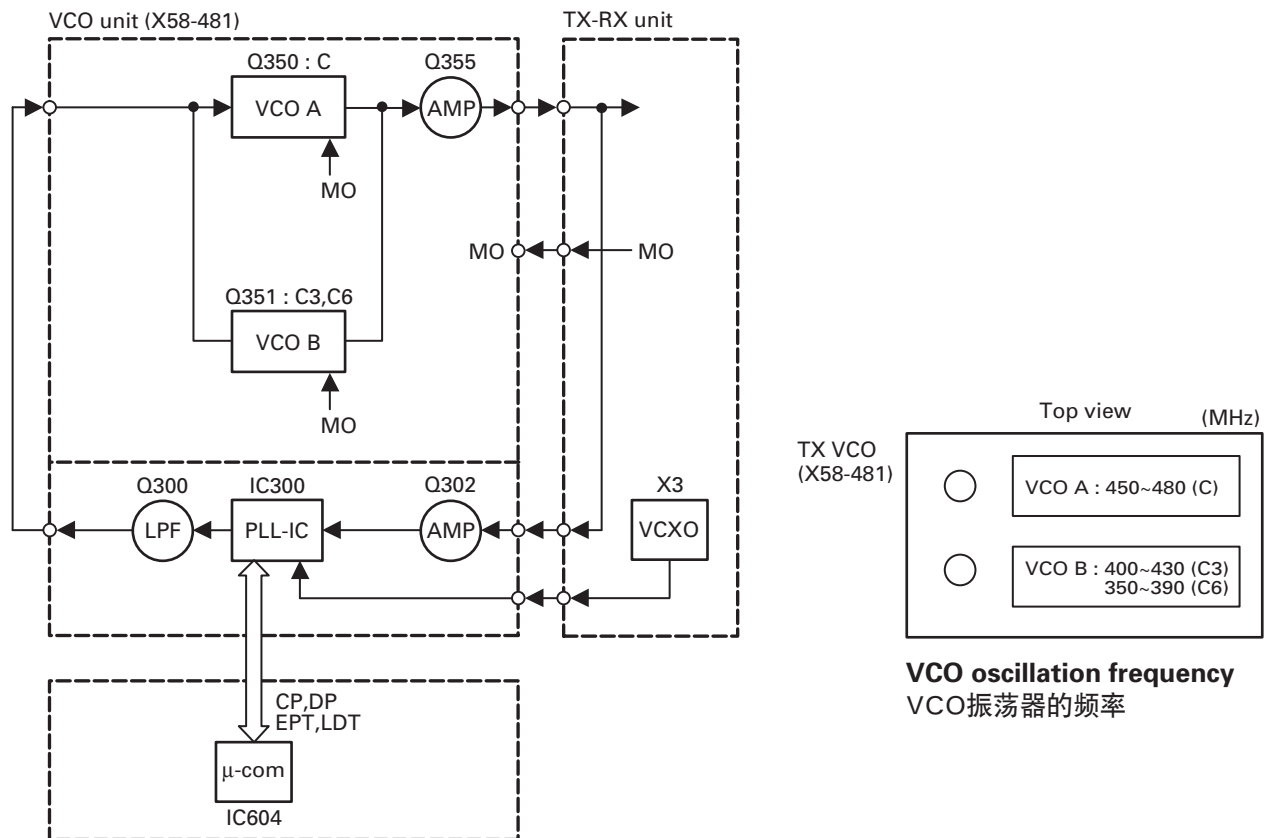


Fig. 6 Transmitter PLL / 图6 发射机PLL

CIRCUIT DESCRIPTION / 电路说明

5. Control Circuit

The control circuit mainly located in the control section of TX-RX unit (X57-696 B/2) consists of the following : 5-1 CPU, 5-2 memory circuit, 5-3 CPU clock shift, 5-4 shift register circuit, 5-5 display circuit, 5-6 DSP circuit, 5-7 base-band circuit, 5-8 RS-232C circuit, and 5-9 power supply circuit.

5-1. CPU

The CPU (IC604) is a 16bit single-chip microcomputer containing a 32k ROM and 3k RAM. This CPU controls the flash ROM, the DSP, the receiver circuit, the transmitter circuit, the control circuit, and the display circuit and transfers data to or from an external device.

5-2. Memory Circuit

IC609 has a flash ROM with a capacity of 2M bits that contains the control program for the CPU, the signal processing program for DSP and data such as channels and operating features.

This program can be easily written from an external device. Data such as the operating status are programmed into the EEPROM (IC600).

5-3. CPU Clock Shift

There are the 14.754MHz clock for the CPU (IC604) and the 16.515MHz clock for the DSP (IC618) at the control section of TX-RX unit (X57-696). When these clocks are multiplexed with the reception frequency, they become an internal beat signal. To prevent this, by tuning Q600 and Q604 on the clock frequency is shifted. (Shift on/off can be set through programming.)

5. 控制电路

控制电路主要设置在TX-RX单元(X57-696 B/2)的控制部分,由以下部分构成:5-1 CPU,5-2 存储器电路,5-3 CPU时钟移位,5-4 移位寄存器电路,5-5 显示电路,5-6 DSP电路,5-7 基带电路,5-8 RS-232C电路和5-9 电源供电电路。

5-1. CPU

CPU (IC604) 是16位单片微计算机,包括32k ROM和3k RAM。本CPU控制FLASHROM, DSP, 接收机电路, 发射机电路, 控制电路以及显示电路和向外部单元传送或者从外部单元接收数据。

5-2. 存储器电路

IC609具备容量达2MB的FLASH ROM, 包括CPU的控制程序, DSP的信号处理程序和诸如频道和操作特性的数据。

该程序可以从外部装置方便地写入。诸如操作状态等数据编程在EEPROM (IC600) 中。

5-3. CPU时钟移位

在TX-RX单元(X57-696)的控制部分, 有用于CPU (IC604) 的14.754MHz时钟和用于DSP (IC618) 的16.515MHz时钟。这些时钟与接收的频率多路传输时, 将成为内部节拍信号。为了防止出现这种现象, 接通Q600和Q604, 使得时钟频率移位。(移位的接通/切断可以通过编程设定)

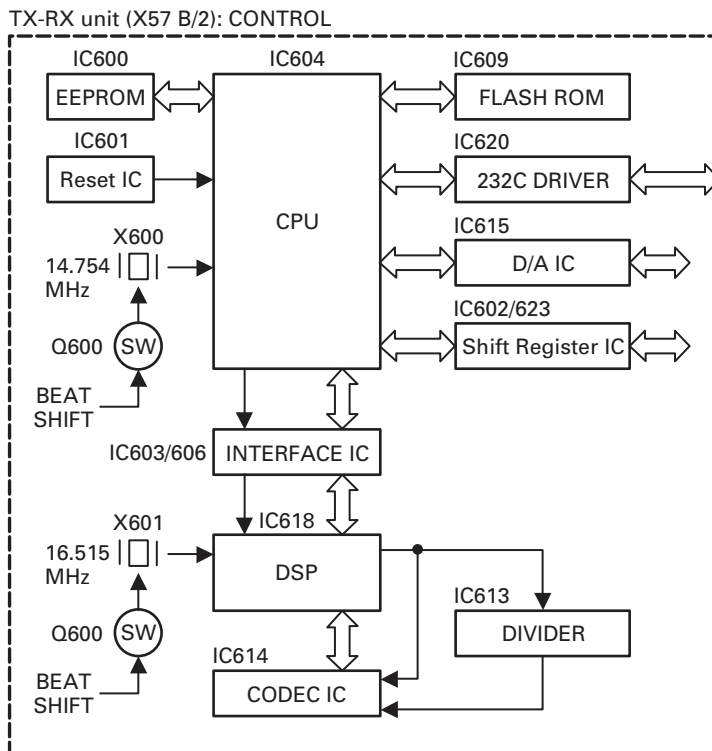


Fig. 7 Control circuit / 图7 控制电路

CIRCUIT DESCRIPTION / 电路说明

5-4. Shift Register Circuit

Serial data is sent to the shift register (IC502 to IC505 located in display unit, IC602, IC623, IC7 located in TX-RX unit) from the CPU (IC604) to control various functions in the unit.

5-5. Display Circuit

The display circuit (X54-333) contains two 7-segment LEDs D506, D507 (orange), D503 (red : transmission), two-color D504 (green : busy, orange : selective called), two-color LED D505 (red : backup, green : main DC), LEDs in switches S501 to S506, IC502, IC503, IC504, and IC505 to display this model channels and states.

IC502 to IC505 are shift registers which convert serial data from the CPU to parallel data and light LEDs.

Q507, Q510, and Q511 are switching transistors which control two-color LED D505.

IC506, and IC507 are three-pin power supply ICs which produce power used for the display circuit.

5-4. 移位寄存器电路

串行数据从CPU (IC604) 送至本移位寄存器 (设置在显示单元的IC502至IC505和设置在TX-RX单元的IC602, IC603), 控制单元的各种功能。

5-5. 显示电路

显示电路 (X54-333) 包括两个7-段LED D506, D507 (橙色), D503 (红色 : 传输), 双色D504 (绿色 : 忙, 橙色 : 选择呼叫), 双色LED D505 (红色 : 后备, 绿色 : 主DC), 开关S501, S506, IC502, IC503, IC504和IC505内用来显示本机工作信道和工作状态的LED。

IC502到IC505是移位寄存器, 将来自CPU的串行数据转换成并行数据并点亮LED。

Q507, Q510和Q511是开关晶体管, 用来控制双色LED D505。

IC506和IC507是三脚电源供应IC, 用来为显示电路提供电源。

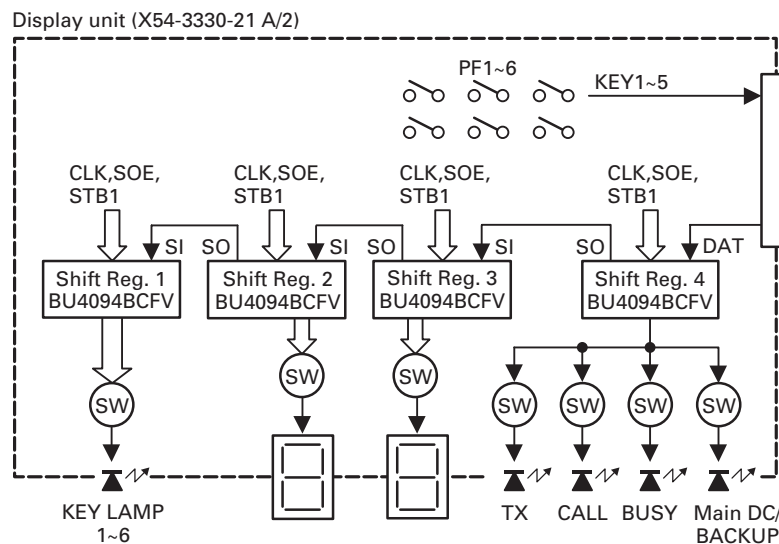


Fig. 8 Display circuit / 图8 显示电路

5-6. DSP

The DSP circuit filters transmit/receive audio signal and encode/decodes signaling (QT, DQT). This circuit consists of IC618, IC612, IC613, IC614, IC603, IC606, IC608, IC610, IC616, and IC619.

The receive signal DET is converted from analog to digital by IC614 with a sampling frequency of 16.128kHz. The digitized audio signal is sent to DSP IC618 to process the signaling signal and audio signal. The processed digital audio signal is fed to CODEC IC613, converted from digital to analog, and the analog signal is output from pin 16 (AOUTR). Then, the audio signal is amplified by IC619 (B/2), passes through the IC619 (A/2) low-pass filter, and goes to an electronic volume IC615.

The transmit audio signal coming from IC605 is amplified by IC610, fed to pin 3 (AINL) of CODEC IC614, and converted from analog to digital at a sampling frequency of 16.128kHz. The digitized transmit audio signal is AGC-processed, pre-emphasized and filtered at 300Hz to 3kHz by DSP IC618, and

5-6. DSP电路

DSP电路对发射/接收的音频信号进行滤波, 并且编码/解码信号 (QT, DQT)。本电路由IC618, IC612, IC613, IC614, IC603, IC606, C608, IC610, IC616和IC619构成。

接收信号DET以16.128kHz的取样频率通过IC614进行模数转换。数码化了的音频信号送至DSP IC618, 对信令信号和音频信号进行处理。处理后的数码信号送至CODEC IC614进行数模转换, 然后模拟信号从管脚16 (AOUTR) 输出。音频信号由IC619 (B/2) 放大, 通过IC619 (A/2) 低通滤波器, 送至电子电位器IC615。

来自IC605的发射音频信号由IC610放大, 送至CODEC IC614的管脚3 (AINL), 以16.128kHz的取样频率进行模数转换。数码化了的发射音频信号由DSP IC618在300Hz至3kHz进行AGC处

CIRCUIT DESCRIPTION / 电路说明

the resulting signal is fed back to CODEC IC614, and converted from digital to analog, and the analog signal is output from pin 15 (AOUTL). The transmit signal from AOUTL is amplified by IC616 (B/2), passes through the IC616 (A/2) low-pass filter, and goes to the IC611 (A/2) summing amplifier.

IC613 is a counter IC and the clock required for the CODEC and DSP is generated by dividing the 16.515MHz clock signal produced by DSP IC618.

IC603 and IC606 are interface IC between the CPU operated at 5.0V and the DSP operated at 3.3V.

5-7. Base-Band Circuit

The base-band circuit switches between the modulation signal to the transmitter circuit, and remote audio and adjusts their levels. This circuit consists of IC605, IC607, IC611, IC615, and IC617.

Modulation inputs include local microphone input, low-speed data (LSD), high-speed data (HSD), external audio input (TA), and external data input (TD), and demodulation outputs include receive audio output (RA), and receive data output (RD).

The multiplexer (IC605) changes signals, the electronic volume (IC615) adjusts the level, and the operational amplifier (IC607, IC611, IC617) amplifiers and sums signals.

5-8. RS-232C Circuit

The RS-232C circuit connects the RS-232C serial port of a personal computer directly to this model to perform FPU operation. The FPU operation can also be performed by connecting a programming cable (KPG-46) to the local microphone on the front panel. But, if the D-sub connector on the rear panel is used, the programming cable is not required. The 232C driver IC (IC620) changes the TTL-232C level. The firmware can only be rewritten with the local microphone on the front panel.

理, 预加重处理和滤波处理, 将获得的信号反馈至CODEC IC614, 从数码方式转换成模拟方式, 然后模拟信号从管脚15 (AOUTL) 输出。来自AOUTL的发射信号由IC616 (B/2) 放大, 通过IC616 (A/2) 低通滤波器, 然后送至IC611 (A/2) 加法放大器。

IC613是计数IC, CODEC和DSP需要的时钟通过对DSP IC618产生的16.515MHz时钟信号进行分频获得。

IC603和IC606是以5.0V运行的CPU和以3.3V运行的DSP之间的接口IC。

5-7. 基带电路

基带电路在调制信号至发射机电路和遥控音频之间切换, 并且调节其电平。该电路由IC605, IC607, IC611, IC615和IC617构成。

调制输入包括本机麦克风输入, 低速数据 (LSD), 高速数据 (HSD), 外部音频输入 (TA) 以及外部数据输入 (TD), 调制输出包括接收音频输出 (RA) 以及接收数据输出 (RD)。

多路转接器 (IC605) 改变信号, 电子电位器 (IC615) 调节电平, 运算放大器 (IC607, IC611, IC617) 放大和总计信号。

5-8. RS-232C电路

RS-232C电路将个人电脑的RS-232C串行端口直接与本机连接, 完成FPU运行。FPU运行还可以通过向前面板的本机麦克风连接编程电缆 (KPG-46) 完成。但是如果使用后面板上的D-sub连接器, 则不需要本编程电缆。232C驱动器IC (IC620) 调整TTL-232C电平。该固件仅可以使用前面板的本机麦克风重写。

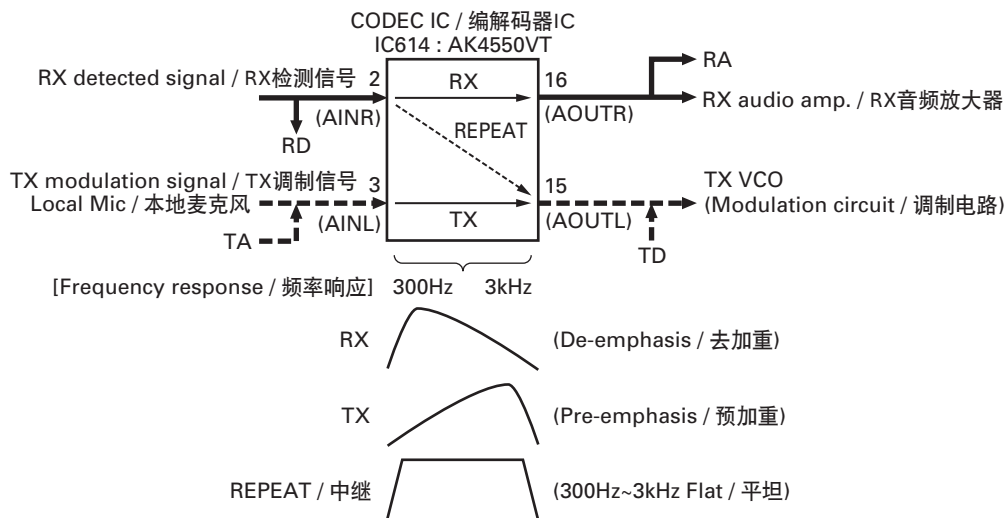


Fig. 9 An audio signal course and the frequency characteristic / 图9 音频信号路线和频率特性

CIRCUIT DESCRIPTION / 电路说明

5-9. Power Supply Circuit

The power supply circuit generates power to operate the CPU, DSP, flash ROM, bi-directional buffer, and base-band circuit. This circuit consists of IC624, IC625, IC626, IC627, IC628, and IC630.

6. DC Power Supply Circuit

6-1. DC Source Switching Relay Circuit

1. The final unit contains a relay (K1) for switching between the Main DC and Backup Battery.

If an external power source is connected to the Main DC terminal, the Backup terminal is isolated by the relay. If the Main DC turns OFF due to power failure, it is switched to the Backup terminal by the relay.

The CPU monitors which is used, Main DC or Backup Battery.

2. Trickle charge circuit

If both Main DC and Backup Battery are connected, trickle charging of 0.5A max. can be performed from the Main DC power supply to the Battery.

(The default is OFF. See the Modification section for information on the modification method.)

The battery is charged from the Main DC with D8, D9 and R61. If it exceeds 0.5A, the charging circuit is turned OFF by D9.

6-2. SB Switching Relay Circuit

1. SB (Switched +B) is supplied through the relay (K1) in the TX-RX unit A/2.

When S507 (DC source switch) in the display unit is turned ON, the relay (K1) is turned ON to output SB.

2. If +B exceeds 18V, the relay is forcibly turned OFF by D12 and Q25 to interrupt the power and protect the main unit.

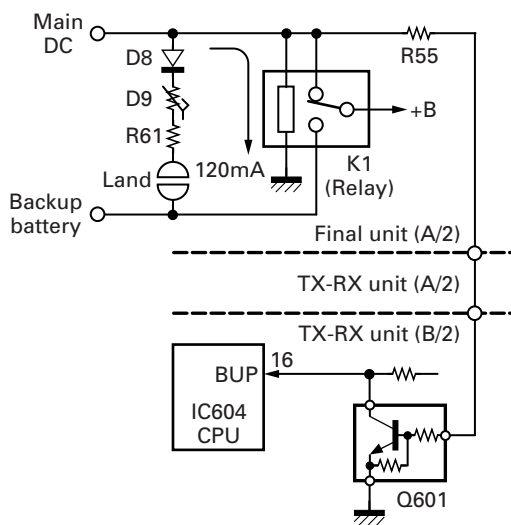


Fig. 10 DC source switching relay circuit
图10 DC电源切换中继电路

5-9. 电源供电电路

电源供电电路提供CPU, DSP, FLASH ROM, 双向缓冲器和基带电路的运行电源。该电路由IC624, IC625, IC626, IC627, IC628和IC630构成。

6. DC电源供电电路

6-1. DC电源切换中继电路

1. 末级单元设有实现主DC与后备电池切换的继电器(K1)。外部电源与主DC端子连接时,继电器切断后备电池端子侧。当发生停电等主DC切断时,继电器切换到后备电池端子侧。另外,CPU监视使用主DC或者后备电池。

2. 涓流充电电路

主DC和后备电池同时连接时,可以从主DC电源向电池进行最大为0.5A的涓流充电。

(初始值为切断。有关变更方法请参照修改部分)

从主DC经过D8, D9, R61向电池充电。电流超过0.5A时, D9切断充电电路。

6-2. SB切换中继电路

1. SB (切换的 +B) 由TX-RX单元A/2的继电器K1提供。

接通显示单元的S507 (DC电源开关) 后,继电器K1接通, SB输出。

2. +B超过18V时,由D12, Q25强制关闭继电器,切断电源保护本机。

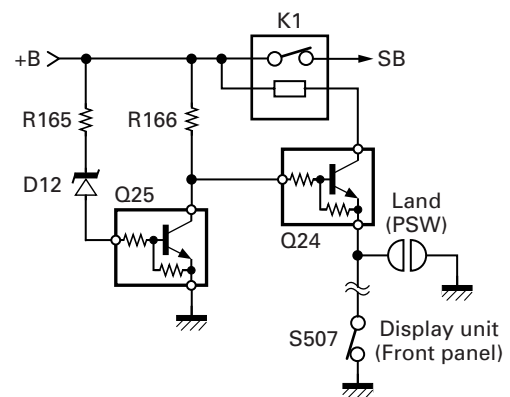


Fig. 11 SB switching relay circuit
图11 SB切换中继电路

Main CPU : 30622M4A-487GP
(TX-RX unit IC604)

■ Pin Function

Pin No.	Name	I/O	Function
1	IO5	I/O	Aux I/O No.5 (Acc D-sub 25 pin)
2	IO4	I/O	Aux I/O No.4 (Acc D-sub 25 pin)
3	5TN	I	Not used
4	IO2	I/O	Aux I/O No.2 (Acc D-sub 25 pin)
5	IO1	I/O	Aux I/O No.1 (Acc D-sub 25 pin)
6	BYTE	-	5V
7	CNVss	-	GND
8	ENT	O	TX PLL IC enable
9	ENR	O	RX PLL IC enable
10	Reset	I	Microcomputer reset input
11	Xout	-	14.7456MHz
12	Vss	-	GND
13	Xin	-	14.7456MHz
14	Vcc	-	5V
15	NMI	-	Not used
16	BUP	I	Backup battery detect H : Backup, L : Main
17	TEMP	I	Temperature detect for fan action H : Temp high, L : Temp low
18	INTy	I	INT request from DSP
19	CLK	O	Common clock
20	DAT	O	Common data
21	SFT	O	Beat shift H : On, L : Off
22	LD1	O	Control D/A converter LD
23	IO3	I/O	Aux I/O No.3 (Acc D-sub 25 pin)
24	BEEP	O	Beep output
25	LD2	O	D/A converter 2LD
26	RS	O	DSP reset H : Off, L : On
27	EPTT	O	Acc PTT (Acc D-sub 25 pin) H : Off, L : On
28	PTT	I	Mic PTT H : Off, L : On
29	TXD1	O	Mic TXD
30	RXD1	I	Mic HOOK/RXD
31	SCLK	O	EEPROM clock
32	SDAT	I/O	EEPROM data
33	TXD0	O	Acc TXD (Acc D-sub 25 pin)
34	RXD0	I	Acc RXD (Acc D-sub 25 pin)
35	CP	O	PLL IC clock
36	DP	O	PLL IC data
37	RDY	I	CPU ready input

主CPU : 30622M4A-487GP
(TX-RX单元IC604)

■ 端子功能

管脚号	名称	输入/输出	功能
1	IO5	输入/输出	AUX输入/输出No.5 (Acc D-sub 25插脚)
2	IO4	输入/输出	AUX输入/输出No.4 (Acc D-sub 25插脚)
3	5TN	输入	不使用
4	IO2	输入/输出	AUX输入/输出No.2 (Acc D-sub 25插脚)
5	IO1	输入/输出	AUX输入/输出No.1 (Acc D-sub 25插脚)
6	BYTE	-	5V
7	CNVss	-	接地
8	ENT	输出	TX PLL集成电路开启
9	ENR	输出	RX PLL集成电路开启
10	Reset	输入	微机复位输入
11	Xout	-	14.7456MHz
12	Vss	-	接地
13	Xin	-	14.7456MHz
14	Vcc	-	5V
15	NMI	-	不使用
16	BUP	输入	后备电池检测 H : 后备电源, L : 主电源
17	TEMP	输入	风扇运行温度检测 H : 高温, L : 低温
18	INTy	输入	来自DSP的INT请求
19	CLK	输出	公共时钟
20	DAT	输出	公共数据
21	SFT	输出	节拍位移 H : 开启, L : 关闭
22	LD1	输出	控制数/模变换器LD
23	IO3	输入/输出	AUX输入/输出No.3 (Acc D-sub 25插脚)
24	BEEP	输出	提示音输出
25	LD2	输出	数/模变换器2LD
26	RS	输出	DSP复位 H : 关闭, L : 开启
27	EPTT	输出	Acc PTT (Acc D-sub 25插脚) H : 切断, L : 接通
28	PTT	输入	麦克风PTT H : 关闭, L : 开启
29	TXD1	输出	麦克风TXD
30	RXD1	输入	麦克风HOOK/RXD
31	SCLK	输出	EEPROM时钟
32	SDAT	输入/输出	EEPROM数据
33	TXD0	输出	Acc TXD (Acc D-sub 25插脚)
34	RXD0	输入	Acc RXD (Acc D-sub 25插脚)
35	CP	输出	PLL集成电路时钟
36	DP	输出	PLL集成电路数据
37	RDY	输入	CPU就绪输入

SEMICONDUCTOR DATA / 半导体数据

Pin No.	Name	I/O	Function
38	ALE	-	Not used
39	HOLD	-	Not used
40	HLDA	-	Not used
41	BCLK	O	Not used
42	RD	O	Flash ROM WR/DSP HDS1
43	BHE	-	Not used
44	WR	O	Flash ROM WR/DSP HDS2
45	STB2	O	Control shift register STB
46	INTx	O	DSP interrupt H : Off, L : On
47	HCS	O	DSP HCS
48	CS0	O	Flash ROM CS
49	A19	O	Not used
50~59	A18~A9	O	Flash ROM address bus
60	Vcc	-	5V
61	A8	O	Flash ROM address bus
62	Vss	-	GND
63~70	A7~A0	O	Flash ROM address bus
71	EMON	I	Acc monitor (Acc D-sub 25 pin) H : Off, L : On
72	LDR	I	RX VCO lock detect H : Lock, L : Unlock
73	LDT	I	TX VCO lock detect H : Lock, L : Unlock
74,75	KEY5,KEY4	O	Key matrix output
76~78	KEY3~KEY1	I	Key matrix input
79~86	D7~D0	I/O	Flash ROM data bus
87	FWD	I	RF power down level input
88	RSSI	I	RSSI level input
89	ASQ	I	Squelch level input
90	VL I	I	Volume level input
91	BATT	I	Power supply voltage level input
92	AI1	I	Aux input No.1 (Acc D-sub 25 pin)
93	AI2	I	Aux input No.2 (Acc D-sub 25 pin)
94	AVss	-	GND
95	AI3	I	Aux input No.3 (Acc D-sub 25 pin)
96	Vref	-	5V
97	AVcc	-	5V
98	STB1	O	Display shift register STB
99	SOE	O	Shift register common OE
100	IO6	I/O	Aux I/O No.6 (Acc D-sub 25 pin)

管脚号	名称	输入/输出	功能
38	ALE	-	不使用
39	HOLD	-	不使用
40	HLDA	-	不使用
41	BCLK	输出	不使用
42	RD	输出	FLASH ROM WR/DSP HDS1
43	BHE	-	不使用
44	WR	输出	FLASH ROM WR/DSP HDS2
45	STB2	输出	控制移位寄存器STB
46	INTx	输出	DSP中断 H : 关闭, L : 开后
47	HCS	输出	DSP HCS
48	CS0	输出	FLASH ROM CS
49	A19	输出	不使用
50 ~ 59	A18 ~ A9	输出	FLASH ROM地址总线
60	Vcc	-	5V
61	A8	输出	FLASH ROM地址总线
62	Vss	-	接地
63 ~ 70	A7 ~ A0	输出	FLASH ROM地址总线
71	EMON	输入	Acc监听器 (Acc D-sub 25插脚) H : 切断, L : 接通
72	LDR	输入	RX VCO锁定检测 H : 锁定
73	LDT	输入	TX VCO锁定检测 H : 锁定
74, 75	KEY5, KEY4	输出	键矩阵输出
76 ~ 78	KEY3 ~ KKEY1	输入	键矩阵输入
79 ~ 86	D7 ~ D0	输入/输出	FLASH ROM数据总线
87	FWD	输入	射频功率衰减电平输入
88	RSSI	输入	RSSI电平输入
89	ASQ	输入	静噪电平输入
90	VL I	输入	音量电平输入
91	BATT	输入	电源供电电平输入
92	AI1	输入	AUX输入No.1 (Acc D-sub 25插脚)
93	AI2	输入	AUX输入No.2 (Acc D-sub 25插脚)
94	AVss	-	接地
95	AI3	输入	AUX输入No.3 (Acc D-sub 25插脚)
96	Vref	-	5V
97	AVcc	-	5V
98	STB1	输出	显示移位寄存器STB
99	SOE	输出	移位寄存器共用OE
100	IO6	输入/输出	AUX输入/输出No.6 (Acc D-sub 25插脚)

DSP : 320VC5402PGE (TX-RX unit IC618)

■ Pin Function

Pin No.	Name	I/O	Function
1,2	NC1,NC2	-	Not used (No connection)
3	Vss	-	GND
4	DVDD	-	VDD for I/O pins (+3.3V)
5	A0	O	Not used (No connection)
6	HD0	I/O	HPI data bus
7~11	A1~A5	O	Not used (No connection)
12	NC3	-	Not used (No connection)
13	HAS	I	HPI address strobe (Pull up)
14	Vss	-	GND
15	NC4	-	Not used (No connection)
16	CVDD	-	VDD for core CPU (+1.8V)
17	HCS	I	HPI chip select
18	HR/W	I	HPI read/write
19	READY	I	Data ready (Pull up)
20	PS	O	Not used (No connection)
21	DS	O	Not used (No connection)
22	IS	O	Not used (No connection)
23	R/W	O	Not used (No connection)
24	MSTRB	O	Not used (No connection)
25	IOSTRB	O	Not used (No connection)
26	MSC	O	Not used (No connection)
27	XF	O	CODEC control H : Power down, L : Active
28	HOLDA	-	Not used (No connection)
29	IAQ	-	Not used (No connection)
30	HOLD	I	Hold (Pull up)
31	BIO	I	Serial data synchronize input
32	MP/MC	I	Not used (Pull down)
33	DVDD	-	VDD for I/O pins (+3.3V)
34	Vss	-	GND
35~38	NC5~NC8	-	Not used (No connection)
39	HCNTL0	I	HPI control 0
40	Vss	-	GND
41	BCLKR0	I	Receive clock input (SCLK : 516.09375kHz)
42	BCLKR1	-	Not used (No connection)
43	BFSR0	I	Frame sync. for receiver input (LRCK : 16.128kHz)

DSP : 320VC5402PGE (TX-RX单元IC618)

■ 端子功能

管脚号	名称	输入/输出	功能
1, 2	NC1, NC2	-	不使用 (无连接)
3	Vss	-	接地
4	DVDD	-	输入/输出插脚的VDD (+3.3V)
5	A0	输出	不使用 (无连接)
6	HD0	输入/输出	HPI数据总线
7 ~ 11	A1 ~ A5	输出	不使用 (无连接)
12	NC3	-	不使用 (无连接)
13	HAS	输入	HPI地址选通 (推上)
14	Vss	-	接地
15	NC4	-	不使用 (无连接)
16	CVDD	-	主CPU的VDD (+1.8V)
17	HCS	输入	HPI选片
18	HR/W	输入	HPI读/写
19	READY	输入	数据就绪 (推上)
20	PS	输出	不使用 (无连接)
21	DS	输出	不使用 (无连接)
22	IS	输出	不使用 (无连接)
23	R/W	输出	不使用 (无连接)
24	MSTRB	输出	不使用 (无连接)
25	IOSTRB	输出	不使用 (无连接)
26	MSC	输出	不使用 (无连接)
27	XF	输出	CODEC控制 H : 功率下降, L : 有效
28	HOLDA	-	不使用 (无连接)
29	IAQ	-	不使用 (无连接)
30	HOLD	输入	保留 (推上)
31	BIO	输入	串行数据同步输入
32	MP/MC	输入	不使用 (下拉)
33	DVDD	-	输入/输出插脚的VDD (+3.3V)
34	Vss	-	接地
35 ~ 38	NC5 ~ NC8	-	不使用 (无连接)
39	HCNTL0	输入	NPI控制0
40	Vss	-	接地
41	BCLKR0	输入	接收时钟输入 (SCLK : 516.09375kHz)
42	BCLKR1	-	不使用 (无连接)
43	BFSR0	输入	接收机输入的帧同步 (LRCK : 16.128kHz)

SEMICONDUCTOR DATA / 半导体数据

Pin No.	Name	I/O	Function
44	BFSR1	I	Frame sync. for receiver input (LRCK : 16.128kHz)
45	BDR0	I	Serial data receive input
46	HCNTL1	I	HPI control 1
47	BDR1	-	Not used (No connection)
48	BCLKX0	I	Transmit clock input (SCLK : 516.09375kHz)
49	BCLKX1	O	Master clock output (MCLK : 4.12875MHz)
50	Vss	-	GND
51	HINT/TOUT1	O	Boot mode select (Pull up)
52	CVDD	-	VDD for core CPU (+1.8V)
53	BFSX0	I	Frame sync. for transmitter input (LRCK : 16.128kHz)
54	BFSX1	I	Frame sync. for transmitter input (LRCK : 16.128kHz)
55	HRDY	-	Not used (No connection)
56	DVDD	-	VDD for I/O pins (+3.3V)
57	Vss	-	GND
58	HD1	I/O	HPI data bus
59	BDX0	O	Serial data transmit output
60	BDX1	-	Not used (No connection)
61	IACK	-	Not used (No connection)
62	HBIL	I	Byte identification (HPI)
63	NMI	I	Not used (Pull up)
64	INT0	I	Command interrupt from host CPU
65	INT1	I	Not used (Pull up)
66	INT2	I	Boot mode select (Pull up)
67	INT3	I	Not used (Pull up)
68	CVDD	-	VDD for core CPU (+1.8V)
69	HD2	I/O	HPI data bus
70	Vss	-	GND
71~74	NC9~NC12	-	Not used (No connection)
75	DVDD	-	VDD for I/O pins (+3.3V)
76	Vss	-	GND
77	CLKMD1	I	Clock mode select (Pull down)
78	CLKMD2	I	Clock mode select (Pull up)
79	CLKMD3	I	Clock mode select (Pull down)
80	NC13	-	Not used (No connection)
81	HD3	I/O	HPI data bus

管脚号	名称	输入/输出	功能
44	BFSR1	输入	接收机输入的帧同步 (LRCK : 16.128kHz)
45	BDR0	输入	串行数据接收输入
46	HCNTL1	输入	HPI控制1
47	BDR1	-	不使用(无连接)
48	BCLKX0	输入	发射时钟输入 (SCLK : 516.09375kHz)
49	BCLKX1	输出	主时钟输入 (MCLK : 4.12875MHz)
50	Vss	-	接地
51	HINT/TOUT1		引导模式选择(推上)
52	CVDD	-	主CPU的VDD(+1.8V)
53	BFSX0	输入	发射机输入的帧同步 (LRCK : 16.128kHz)
54	BFSX1	输入	发射机输入的帧同步 (LRCK : 16.128kHz)
55	HRDY	-	不使用(无连接)
56	DVDD	-	输入/输出插脚的VDD(+3.3V)
57	Vss	-	接地
58	HD1	输入/输出	HPI数据总线
59	BDX0	输出	串行数据发射输出
60	BDX1	-	不使用(无连接)
61	IACK	-	不使用(无连接)
62	HBIL	输入	字节识别(HPI)
63	NMI	输入	不使用(推上)
64	INT0	输入	来自主CPU的指令中断
65	INT1	输入	不使用(推上)
66	INT2	输入	引导模式选择(推上)
67	INT3	输入	不使用(推上)
68	CVDD	-	主CPU的VDD(+1.8V)
69	HD2	输入/输出	HPI数据总线
70	Vss	-	接地
71~74	NC9~NC12	-	不使用(无连接)
75	DVDD	-	输入/输出插脚的VDD(+3.3V)
76	Vss	-	接地
77	CLKMD1	输入	时钟模式选择(拉下)
78	CLKMD2	输入	时钟模式选择(推上)
79	CLKMD3	输入	时钟模式选择(拉下)
80	NC13	-	不使用(无连接)
81	HD3	输入/输出	HPI数据总线

Pin No.	Name	I/O	Function
82	TOUT0	-	Not used (No connection)
83	EMU0	I/O	Emulator 0 (to JTAG connector)
84	EMU1/OFF	I/O	Emulator 1 (to JTAG connector)
85	TDO	O	Test data output (to JTAG connector)
86	TDI	I	Test data input (to JTAG connector)
87	TRST	I	Test reset (to JTAG connector)
88	TCK	I	Test clock (to JTAG connector)
89	TMS	I	Test mode select (to JTAG connector)
90	NC14	-	Not used (No connection)
91	CVDD	-	VDD for core CPU (+1.8V)
92	HPIENA	I	Not used (Pull up)
93	Vss	-	GND
94	CLKOUT	O	Not used (No connection)
95	HD4	I/O	HPI data bus
96	X1	-	16.515MHz (System clock)
97	X2/CLKIN	-	16.515MHz (System clock)
98	RS	I	DSP reset input
99~104	D0~D5	-	Not used (No connection)
105	A6	O	Not used (No connection)
106	Vss	-	GND
107~109	A7~A9	O	Not used (No connection)
110	NC15	-	Not used (No connection)
111	Vss	-	GND
112	DVDD	-	VDD for I/O pins (+3.3V)
113~119	D6~D12	-	Not used (No connection)
120	HD5	I/O	HPI data bus
121~123	D13~D15	-	Not used (No connection)
124	HD6	I/O	HPI data bus
125	CVDD	-	VDD for core CPU (+1.8V)
126	NC16	-	Not used (No connection)
127	HDS1	I	HPI data strobe 1 (Pull up)
128	Vss	-	GND
129	HDS2	I	HPI data strobe 2 (Pull down)
130	DVDD	-	VDD for I/O pins (+3.3V)
131~134	A10~A13	O	Not used (No connection)
135	HD7	I/O	HPI data bus
136~141	A14~A19	O	Not used (No connection)
142	CVDD	-	VDD for core CPU (+1.8V)
143,144	NC17,NC18	-	Not used (No connection)

管脚号	名称	输入/输出	功能
82	TOUT0	-	不使用(无连接)
83	EMU0	输入/输出	仿真器0(至JTAG连接器)
84	EMU1/OFF	输入/输出	仿真器1(至JTAG连接器)
85	TDO	输出	试验数据输出(至JTAG连接器)
86	TDI	输入	试验数据输入(至JTAG连接器)
87	TRST	输入	试验复位(至JTAG连接器)
88	TCK	输入	试验时钟(至JTAG连接器)
89	TMS	输入	试验模式选择(至JTAG连接器)
90	NC14	-	不使用(无连接)
91	CVDD	-	主CPU的VDD(+1.8V)
92	HPIENA	输入	不使用(推上)
93	Vss	-	接地
94	CLKOUT	输出	不使用(无连接)
95	HD4	输入/输出	HPI数据总线
96	X1	-	16.515MHz(系统时钟)
97	X2/CLKIN	-	16.515MHz(系统时钟)
98	RS	输入	DSP预设输入
99~104	D0~D5	-	不使用(无连接)
105	A6	输出	不使用(无连接)
106	Vss	-	接地
107~109	A7~A9	输出	不使用(无连接)
110	NC15	-	不使用(无连接)
111	Vss	-	接地
112	DVDD	-	输入/输出插脚的VDD(+3.3V)
113~119	D6~D12	-	不使用(无连接)
120	HD5	输入/输出	HPI数据总线
121~123	D13~D15	-	不使用(无连接)
124	HD6	输入/输出	HPI数据总线
125	CVDD	-	主CPU的VDD(+1.8V)
126	NC16	-	不使用(无连接)
127	HDS1	输入	HPI数据选通1(推上)
128	Vss	-	接地
129	HDS2	输入	HPI数据选通2(拉下)
130	DVDD	-	输入/输出插脚的VDD(+3.3V)
131~134	A10~A13	输出	不使用(无连接)
135	HD7	输入/输出	HPI数据总线
136~141	A14~A19	输出	不使用(无连接)
142	CVDD	-	主CPU的VDD(+1.8V)
143,144	CN17,CN18	-	不使用(无连接)

COMPONENTS DESCRIPTION / 元件说明

Final Unit (X45-374X-XX)

Ref. No.	Part name	Description
IC1	IC	Thermostat
IC2	IC	Voltage regulator
IC3	IC	DC amplifier
Q1,2	Transistor	RF amplifier
Q3,4	FET	TX drive amplifier
Q5	FET	Final amplifier
Q8,9	Transistor	DC switch
D2	Zener diode	Voltage reference
D4,5	Diode	RF detector
D7	Zener diode	Surge protector
D8	Diode	Reverse current protection
D9	Varistor	Current protector
D10	Diode	Surge absorption
D51,52	Diode	Reverse connection protection
D53,55,56	Diode	RF switch

末级单元 (X45-374X-XX)

有关号码	零件名称	说明
IC1	集成电路	自动调温器
IC2	集成电路	稳压器
IC3	集成电路	DC放大器
Q1, 2	晶体管	射频放大器
Q3, 4	场效应晶体管	TX驱动放大器
Q5	场效应晶体管	末级放大器
Q8, 9	晶体管	DC开关
D2	稳压二极管	参考电压
D4, 5	二极管	射频检波器
D7	稳压二极管	过压保护
D8	二极管	反向电流保护
D9	变阻器	电流保护器
D10	二极管	过压吸收
D51, 52	二极管	反向连接保护
D53, 55, 56	二极管	RF开关

Display Unit (X54-3330-21)

Ref. No.	Part name	Description
IC501	MOS IC	MIC amplifier
IC502~505	IC	Shift register
IC506,507	IC	Voltage regulator
Q501,502	Transistor	Level controller
Q503,504	FET	DC switch
Q506	Transistor	DC switch
Q507	FET	DC switch
Q508~511	Transistor	DC switch
Q512~514	FET	DC switch
Q516~519	FET	DC switch
Q521~525	FET	DC switch
D501,502	Diode	AF detector
D503~505	LED	LED
D506,507	LED	7 segment
D508~514	Diode	Surge absorption
D601,602	Diode	Surge absorption
D603	Varistor	Current protector

显示单元 (X54-3330-21)

有关号码	零件名称	说明
IC501	MOS集成电路	麦克风放大器
IC502 ~ 505	集成电路	移位寄存器
IC506, 507	集成电路	稳压器
Q501, 502	晶体管	电平控制器
Q503, 504	场效应晶体管	DC开关
Q506	晶体管	DC开关
Q507	场效应晶体管	DC开关
Q508 ~ 511	晶体管	DC开关
Q512 ~ 514	场效应晶体管	DC开关
Q516 ~ 519	场效应晶体管	DC开关
Q521 ~ 525	场效应晶体管	DC开关
D501, 502	二极管	音频检测器
D503 ~ 505	LED	LED
D506, 507	LED	7段
D508 ~ 514	二极管	过压吸收
D601, 602	二极管	过压吸收
D603	变阻器	电流保护器

TX-RX Unit (X57-696X-XX)

Ref. No.	Part name	Description
IC1,2	IC	Buffer amplifier
IC3~5	IC	Voltage regulator
IC6	IC	D/A converter

TX-RX单元 (X57-696X-XX)

有关号码	零件名称	说明
IC1, 2	集成电路	缓冲放大器
IC3 ~ 5	集成电路	稳压器
IC6	集成电路	数/模变换器

COMPONENTS DESCRIPTION / 元件说明

Ref. No.	Part name	Description
IC7	IC	Shift register
IC9	IC	FM IF system
IC10,11	IC	Voltage regulator
IC600	IC	EEPROM
IC601	IC	Voltage detector
IC602	IC	Shift register
IC603	IC	Bus transceiver
IC604	IC	CPU
IC605	IC	Multiplexer
IC606	IC	Bus transceiver
IC607,608	IC	AF amplifier
IC609	IC	Flash ROM
IC610,611	IC	AF amplifier
IC612	IC	Inverter
IC613	IC	Counter
IC614	IC	CODEC
IC615	IC	D/A converter
IC616,617	IC	AF amplifier
IC618	IC	DSP
IC619	IC	AF amplifier
IC620	IC	RS-232C transceiver
IC621	IC	NAND gate
IC622	IC	Multiplexer
IC623	IC	Shift register
IC624~628	IC	Voltage regulator
IC629	IC	AF power amplifier
IC630	IC	Voltage regulator
IC631,632	IC	AF amplifier
Q1~3	Transistor	RF amplifier
Q4	Transistor	Wide/Narrow switch
Q5,6	Transistor	DC switch
Q7	Transistor	Noise amplifier
Q8,9	Transistor	RF amplifier
Q10	Transistor	Current control
Q11	Transistor	RF amplifier
Q12~15	Transistor	Ripple filter
Q16~19	Transistor	DC switch
Q23~26	Transistor	DC switch
Q27	Transistor	Wide/Narrow switch
Q600	FET	DC switch
Q601	Transistor	DC switch
Q602	FET	DC switch
Q603	Transistor	Inverter

有关号码	零件名称	说明
IC7	集成电路	移位寄存器
IC9	集成电路	FM中频系统
IC10, 11	集成电路	稳压器
IC600	集成电路	EEPROM
IC601	集成电路	电压检测器
IC602	集成电路	移位寄存器
IC603	集成电路	总线收发器
IC604	集成电路	CPU
IC605	集成电路	多路转接器
IC606	集成电路	总线收发器
IC607, 608	集成电路	音频放大器
IC609	集成电路	FLASH ROM
IC610, 611	集成电路	音频放大器
IC612	集成电路	逆变器
IC613	集成电路	计数器
IC614	集成电路	编码译码器
IC615	集成电路	数/模变换器
IC616, 617	集成电路	音频放大器
IC618	集成电路	DSP
IC619	集成电路	音频放大器
IC620	集成电路	RS-232C收发器
IC621	集成电路	NAND门
IC622	集成电路	多路转接器
IC623	集成电路	移位寄存器
IC624 ~ 628	集成电路	稳压器
IC629	集成电路	音频功率放大器
IC630	集成电路	稳压器
IC631, 632	集成电路	音频放大器
Q1 ~ 3	晶体管	射频放大器
Q4	晶体管	宽/窄开关
Q5, 6	晶体管	DC开关
Q7	晶体管	噪音放大器
Q8, 9	晶体管	射频放大器
Q10	晶体管	电流控制
Q11	晶体管	射频放大器
Q12 ~ 15	晶体管	纹波滤波器
Q16 ~ 19	晶体管	DC开关
Q23 ~ 26	晶体管	DC开关
Q27	晶体管	宽/窄开关
Q600	场效应晶体管	DC开关
Q601	晶体管	DC开关
Q602	场效应晶体管	DC开关
Q603	晶体管	逆变器

COMPONENTS DESCRIPTION / 元件说明

Ref. No.	Part name	Description
Q604	FET	DC switch
Q605	Transistor	Inverter
Q606	Transistor	AF mute switch
Q607~609	Transistor	DC switch
Q610	FET	DC switch
Q611,612	Transistor	DC switch
Q613,614	Transistor	Current control
Q615	Transistor	DC switch
D1~4	Diode	Wide/Narrow switch
D5	Diode	Noise detection
D7	Diode	DC switch
D8	Diode	TX switch
D11	Zener diode	Surge protector
D12	Diode	DC switch
D13	Diode	Noise detection
D600	Diode	Surge protector
D606~612	Diode	Surge protector
D614~616	Diode	Surge protector
D618~623	Diode	Surge protector
D626	Variistor	Current protector
D627,628	Diode	Reverse current protector
D629	Diode	Surge protector

有关号码	零件名称	说明
Q604	场效应晶体管	DC开关
Q605	晶体管	逆变器
Q606	晶体管	音频消音开关
Q607~609	晶体管	DC开关
Q610	场效应晶体管	DC开关
Q611,612	晶体管	DC开关
Q613,614	晶体管	电流控制
Q615	晶体管	DC开关
D1~4	二极管	宽/窄开关
D5	二极管	噪音检测
D7	二极管	DC开关
D8	二极管	TX开关
D11	稳压二极管	过压保护
D12	二极管	DC开关
D13	二极管	噪音检测
D600	二极管	过压保护
D606~612	二极管	过压保护
D614~616	二极管	过压保护
D618~623	二极管	过压保护
D626	变阻器	电流保护器
D627,628	二极管	反向电流保护器
D629	二极管	过压保护

RX VCO Unit (X58-480X-XX)

Ref. No.	Part name	Description
IC300	IC	PLL
Q300,301	Transistor	Active filter
Q302	Transistor	Buffer amplifier
Q350,351	FET	VCO OSC
Q352~354	Transistor	DC switch
Q355	Transistor	Buffer amplifier
D350~353	Varicap	Frequency control

RX VCO单元 (X58-480X-XX)

有关号码	零件名称	说明
IC300	集成电路	PLL
Q300,301	晶体管	活性滤波器
Q302	晶体管	缓冲放大器
Q350,351	场效应晶体管	VCO振荡器
Q352~354	晶体管	DC开关
Q355	晶体管	缓冲放大器
D350~353	变容二极管	频率控制

TX VCO Unit (X58-481X-XX)

Ref. No.	Part name	Description
IC300	IC	PLL
Q300,301	Transistor	Active filter
Q302	Transistor	Buffer amplifier
Q350,351	FET	VCO OSC
Q355	Transistor	Buffer amplifier
D350~353	Varicap	Frequency control
D354,355	Varicap	Modulation

TX VCO单元 (X58-481X-XX)

有关号码	零件名称	说明
IC300	集成电路	PLL
Q300,301	晶体管	活性滤波器
Q302	晶体管	缓冲放大器
Q350,351	场效应晶体管	VCO振荡器
Q355	晶体管	缓冲放大器
D350~353	变容二极管	频率控制
D354,355	变容二极管	调制

TKR-850

PARTS LIST / 零件表

* New Parts. △ indicates safety critical components.

Parts without **Parts No.** are not supplied.

Les articles non mentionnés dans le **Parts No.** ne sont pas fournis.

Teile ohne **Parts No.** werden nicht geliefert.

L : Scandinavia

Y : PX (Far East, Hawaii)

Y : AAFES (Europe)

K : USA

T : England

X : Australia

P : Canada

E : Europe

M : Other Areas

TKR-850 (Y54-319X-XX)

FINAL UNIT (X45-374X-XX)

Ref. No.	Address	New parts	Parts No.	Description	Destination
TKR-850					
1	2B		A10-4037-21	CHASSIS	
2	1B		A62-0836-04	PANEL (TX/RX)	
3	1B		A62-0837-04	PANEL (FINAL)	
4	1D		A62-0840-03	PANEL (OUTER)	
5	3A		A62-0933-13	PANEL ASSY (INNER)	
6	3C		A62-0934-03	PANEL ASSY	
8	1F		B10-2635-04	FRONT GLASS ACCESSORY	
9	1F		B11-1259-04	FILTER ACCESSORY	
10	3B	*	B42-7160-04	STICKER (MODEL NAME)	
11	1F	*	B62-1836-00	INSTRUCTION MANUAL	
12	2C,3D	*	B72-2304-04	MODEL NAME-PLATE	C
12	2C,3D	*	B72-2306-04	MODEL NAME-PLATE	C3
12	2C,3D	*	B72-2307-04	MODEL NAME-PLATE	C6
14	2C		E30-3414-05	DC CORD (EXT DC IN)	
15	1C		E30-3418-05	ANTENNA CABLE (BNC)	
16	2C		E30-3419-05	ANTENNA CABLE (N)	
17	1E		E30-3427-15	DC CORD ACCESSORY	
18	1E		E31-3228-05	TEST/SPKR PLUG ACCESSORY	
19	1B		E37-0902-05	DC WIRE (RED)	
20	1B		E37-0903-05	DC WIRE (BLACK)	
21	1C		E37-0904-05	D-SUB CABLE ASSY	
22	3B		E37-0905-15	SPEAKER CABLE	
23	3A		E37-0906-05	LEAD WIRE WITH CONNECTOR (CONT-DISP)	
24	3A		E37-0908-05	LEAD WIRE WITH CONNECTOR (11P)	
25	2B		E37-0909-05	LEAD WIRE WITH CONNECTOR (8P)	
26	1B		E37-0911-05	LEAD WIRE WITH CONNECTOR (3P)	
27	2B		E37-0912-05	COAXIAL CABLE	
28	2C		E37-0913-05	TEST/SPKR CONNECTOR ASSY	
29	1B		E37-0934-05	DC WIRE (ORANGE)	
30	2C		E37-0964-05	DC BACKUP WIRE (BLACK)	
31	2C		E37-0965-05	DC BACKUP WIRE (RED)	
32	2B		E37-0967-05	FLAT CABLE	
33	2C		E70-0402-05	DC BACKUP TERMINAL	
35	1C,1E		F05-1537-05	FUSE (BLADE TYPE) (15A/32V)	
36	2C		F09-0445-05	CAP (D-SUB) ACCESSORY	
37	2C		F09-0471-05	FAN MOTOR	
-			F10-2374-04	SHIELDING PLATE (TX/RX)	
-			F10-2379-04	SHIELDING CASE (TX/RX COMP)	
-			F10-2409-04	SHIELDING CASE (TX/RX FOIL)	
41	1C		F20-3322-04	INSULATING SHEET (BACKUP)	
43	1B,2B		G02-0576-14	FLAT SPRING	
-			G02-0729-14	FLAT SPRING (TX/RX FOIL)	
44	2B		G02-0829-14	FLAT SPRING	
45	3B		G02-0885-13	EARTH SPRING	
51	1B		G02-0894-04	EARTH SPRING (FINAL FET)	
46	2B,3B		G10-1263-04	FIBROUS SHEET (CHASSIS)	
47	3C,2D	*	G10-1264-04	FIBROUS SHEET	
56	3B	*	G10-1344-04	FIBROUS SHEET	
58	3B	*	G10-1345-04	FIBROUS SHEET	
48	1F		G13-1801-04	CUSHION ACCESSORY	
49	1F		G13-1802-04	CUSHION ACCESSORY	
50	2B	*	G13-1886-04	CUSHION (BNC)	

Ref. No.	Address	New parts	Parts No.	Description	Destination
52	1E		H25-0029-04	PROTECTION BAG (60/110/0.07)	
53	1F		H25-0747-04	PROTECTION BAG (250X350)	
54	1E		H25-0762-04	PROTECTION BAG (120X300)	
55	1F		H25-2328-04	PROTECTION BAG (80/250/0.07)	
57	3F		H52-1779-02	ITEM CARTON CASE	
59	1E		J02-0475-05	FOOT ACCESSORY	
60	1E		J02-0492-04	FOOT ACCESSORY	
61	1F		J21-8402-04	MOUNTING HARDWARE ACCESSORY	
64	1B	*	J21-8467-04	MOUNTING HARDWARE (DRIVE FET)	
62	1E		J59-0302-05	GROMMET ACCESSORY	
-			J61-0307-05	BAND	
65	1E		K01-0418-15	HANDLE ACCESSORY	
66	3A		K29-5389-03	KNOB (VOLUME)	
67	3A		K29-5460-02	KEY TOP	
68	3A		K29-9106-04	KNOB (DC SOURCE)	
A	2C		N09-2292-05	HEXAGON HEAD SCREW	
B	1C,2C		N30-2606-46	PAN HEAD MACHINE SCREW	
C	2A,1E		N30-4006-46	PAN HEAD MACHINE SCREW	
D	2B,2C		N30-4014-46	PAN HEAD MACHINE SCREW	
E	1C		N30-4020-45	PAN HEAD MACHINE SCREW	
F	1C,2C		N32-3006-46	FLAT HEAD MACHINE SCREW ACCESSORY	
G	3B,3C		N32-4008-45	FLAT HEAD MACHINE SCREW	
H	1B		N33-3006-45	OVAL HEAD MACHINE SCREW	
J	1E		N35-3006-45	BINDING HEAD MACHINE SCREW	
K	1C		N35-4006-45	BINDING HEAD MACHINE SCREW	
L	1B,3B		N67-3008-46	PAN HEAD SEMS SCREW	
M	1C		N80-2608-45	PAN HEAD TAPTITE SCREW	
N	2C		N87-2606-46	BRAZIER HEAD TAPTITE SCREW	
O	3A		N87-3005-45	BRAZIER HEAD TAPTITE SCREW	
P	2B,3B		N87-3006-46	BRAZIER HEAD TAPTITE SCREW	
R	2C		N90-3014-46	TP HEAD MACHINE SCREW	
70	3A		T07-0247-05	SPEAKER	
-			490-0174-05	ADHESIVE TAPE	
FINAL UNIT (X45-374X-XX) 0-10 : C 0-12 : C3 3-01 : C6					
C1			CC73GCH1H100D	CHIP C 10PF D	C3,C6
C1			CK73GB1H471K	CHIP C 470PF K	C
C3			C90-2146-05	ELECTRO 100UF 25WV	
C6,7			CK73GB1H471K	CHIP C 470PF K	
C8			CC73GCH1H080D	CHIP C 8.0PF D	C
C8			CC73GCH1H100D	CHIP C 10PF D	C3,C6
C10			CK73GB1H471K	CHIP C 470PF K	
C12-15			CK73GB1H471K	CHIP C 470PF K	
C17			CC73GCH1H050C	CHIP C 5.0PF C	C
C17			CC73GCH1H560J	CHIP C 56PF J	C3,C6
C18,19			CK73GB1H471K	CHIP C 470PF K	
C20			CK73FB1H471K	CHIP C 470PF K	
C21			CC73FCH1H120J	CHIP C 12PF J	C
C21			CC73FCH1H220J	CHIP C 22PF J	C3,C6
C22			CC73FCH1H060D	CHIP C 6.0PF D	C

PARTS LIST / 零件表

FINAL UNIT (X45-374X-XX)

Ref. No.	Address	New parts	Parts No.	Description	Destination	Ref. No.	Address	New parts	Parts No.	Description	Destination
C22			CC73FCH1H120J	CHIP C 12PF J	C3,C6	C86			C93-0563-05	CHIP C 18PF J	C6
C23			CK73FB1H471K	CHIP C 470PF K		C88			C93-0556-05	CHIP C 6.0PF D	C3
C24		*	C90-5640-05	ELECTRO 100UF 16WV		C89			C93-0555-05	CHIP C 5.0PF C	C
C25			CK73FB1E104K	CHIP C 0.10UF K	C6	C89			C93-0560-05	CHIP C 10PF D	C6
C26			CC73GCH1H101J	CHIP C 100PF J	C3,C6	C91-98			CK73GB1H471K	CHIP C 470PF K	
C26			CC73GCH1H471J	CHIP C 470PF J	C	C99			CK73FB1E104K	CHIP C 0.10UF K	
C27			CK73GB1H471K	CHIP C 470PF K		C100-102			CK73GB1H471K	CHIP C 470PF K	
C28			CK73FB1E104K	CHIP C 0.10UF K		C103			C92-0628-05	CHIP-TAN 10UF 10WV	
C29			CK73GB1H471K	CHIP C 470PF K		C104			CC73GCH1H101J	CHIP C 100PF J	
C30			CK73FB1E224K	CHIP C 0.22UF K		C105			CK73GB1H471K	CHIP C 470PF K	
C31			C93-0599-05	CHIP C 470PF K		C106			CK73FB1E104K	CHIP C 0.10UF K	
C32			C93-0558-05	CHIP C 8.0PF D	C,C3	C107			CC73GCH1H101J	CHIP C 100PF J	
C32			C93-0560-05	CHIP C 10PF D	C6	C108			CK73FB1E104K	CHIP C 0.10UF K	
C33,34			C93-0565-05	CHIP C 27PF J	C	C109			CC73GCH1H101J	CHIP C 100PF J	
C33,34			C93-0567-05	CHIP C 39PF J	C3	C112			CK73GB1H471K	CHIP C 470PF K	
C33,34			C93-0568-05	CHIP C 47PF J	C6	C113			CK73FB1E104K	CHIP C 0.10UF K	
C35			C93-0599-05	CHIP C 470PF K		C114			CK73GB1H471K	CHIP C 470PF K	
C36			CK73FB1E104K	CHIP C 0.10UF K		C115			CK73FB1E104K	CHIP C 0.10UF K	
C38			CK73GB1H471K	CHIP C 470PF K		C116			CK73GB1H471K	CHIP C 470PF K	
C39			C93-0561-05	CHIP C 12PF J	C	C117			CK73FB1E104K	CHIP C 0.10UF K	
C39			C93-0563-05	CHIP C 18PF J	C3	C118			C93-0554-05	CHIP C 4.0PF C	C
C39			C93-0564-05	CHIP C 22PF J	C6	C119			CK73GB1H471K	CHIP C 470PF K	C
C40			C93-0564-05	CHIP C 22PF J	C	C120			CK73FB1H223K	CHIP C 0.022UF K	
C41			C93-0599-05	CHIP C 470PF K		C121,122			CM73F2H150J	CHIP C 15PF J	C
C42			CC73FCH1H220J	CHIP C 22PF J		C121,122			CM73F2H180J	CHIP C 18PF J	C3
C43			CM73F2H220J	CHIP C 22PF J	C,C3	C121,122			CM73F2H220J	CHIP C 22PF J	C6
C43			CM73F2H390J	CHIP C 39PF J	C6	C123,124			CM73F2H220J	CHIP C 22PF J	C
C44			C93-0556-05	CHIP C 6.0PF D	C	C123,124			CM73F2H270J	CHIP C 27PF J	C3,C6
C44			C93-0560-05	CHIP C 10PF D	C3,C6	C155			C93-0599-05	CHIP C 470PF K	
C46			C93-0599-05	CHIP C 470PF K		C157			CK73GB1H471K	CHIP C 470PF K	
C48			CK73GB1H471K	CHIP C 470PF K		C160			CM73F2H820J	CHIP C 82PF J	
C49			CC73GCH1H101J	CHIP C 100PF J		C161			CC73GCH1H220J	CHIP C 22PF J	
C50			CK73FB1E104K	CHIP C 0.10UF K		C165,166			CK73FB1H471K	CHIP C 470PF K	
C51			C90-2143-05	ELECTRO 47UF 25WV		C167,168			CC73GCH1H220J	CHIP C 22PF J	
C52			CC73GCH1H101J	CHIP C 100PF J		C169			CC73FCH1H560J	CHIP C 56PF J	
C53			CK73FB1E104K	CHIP C 0.10UF K		C170-172			CC73GCH1H220J	CHIP C 22PF J	
C54			C90-2146-05	ELECTRO 100UF 25WV		C173,174			CC73FCH1H220J	CHIP C 22PF J	
C55			C93-0599-05	CHIP C 470PF K		C177			CC73FCH1H150J	CHIP C 15PF J	
C56			CC73FCH1H220J	CHIP C 22PF J		C178			C93-0553-05	CHIP C 3.0PF C	C,C3
C59			CM73F2H100D	CHIP C 10PF D	C	C178			C93-0555-05	CHIP C 5.0PF C	C6
C59			CM73F2H120J	CHIP C 12PF J	C3	C179			CC73FCH1H030C	CHIP C 3.0PF C	
C59			CM73F2H270J	CHIP C 27PF J	C6						
C60			C93-0558-05	CHIP C 8.0PF D	C3	CN1			E04-0154-05	PIN SOCKET	
C60			C93-0560-05	CHIP C 10PF D	C6	CN3			E40-5632-05	PIN ASSY	
C61			CM73F2H820J	CHIP C 82PF J		CN4			E40-3246-05	PIN ASSY	
C68			CK73GB1H471K	CHIP C 470PF K		CN5			E40-5703-05	PIN ASSY	
C69			CC73GCH1H101J	CHIP C 100PF J		CN6-8			E23-0462-05	TERMINAL	
C70			CK73FB1E104K	CHIP C 0.10UF K		F1			F53-0217-05	FUSE	
C71,72			CK73GB1H471K	CHIP C 470PF K		CN51,52			J13-0071-05	FUSE HOLDER	
C75			CK73GB1H471K	CHIP C 470PF K		L1			L40-1075-92	SMALL FIXED INDUCTOR (10NH)	C
C77			CC73GCH1H101J	CHIP C 100PF J		L1			L40-3963-92	SMALL FIXED INDUCTOR (3.9NH)	C3,C6
C78			CK73GB1H471K	CHIP C 470PF K		L2			L40-1075-34	SMALL FIXED INDUCTOR (10NH)	C
C79			CK73FB1E104K	CHIP C 0.10UF K		L2			L40-2775-34	SMALL FIXED INDUCTOR (27NH)	C3,C6
C80			C92-0777-05	ELECTRO 1000UF 25WV		L3			L40-1875-92	SMALL FIXED INDUCTOR (18NH)	C
C81			CM73F2H820J	CHIP C 82PF J		L3			L40-8265-92	SMALL FIXED INDUCTOR (8.2NH)	C3,C6
C83			C93-0556-05	CHIP C 6.0PF D	C	L5			L41-6865-20	SMALL FIXED INDUCTOR	
C83			C93-0557-05	CHIP C 7.0PF D	C3	L6,7			L34-4517-05	AIR-CORE COIL	
C83			C93-0560-05	CHIP C 10PF D	C6	L9			L34-4517-05	AIR-CORE COIL	
C86			C93-0560-05	CHIP C 10PF D	C	L11			L34-4517-05	AIR-CORE COIL	
C86			C93-0561-05	CHIP C 12PF J	C3						

PARTS LIST / 零件表

FINAL UNIT (X45-374X-XX)

DISPLAY UNIT (X54-3330-21)

Ref. No.	Address	New parts	Parts No.	Description	Destination	Ref. No.	Address	New parts	Parts No.	Description	Destination
L12			L34-4523-05	AIR-CORE COIL		R55			RK73GB1J474J	CHIP R 470K J 1/16W	
L14			L40-1575-34	SMALL FIXED INDUCTOR (15NH)	C	R56			RK73GB1J473J	CHIP R 47K J 1/16W	
L14,15			L40-1075-34	SMALL FIXED INDUCTOR (10NH)	C3,C6	R57			RK73GB1J471J	CHIP R 470 J 1/16W	
L15			L40-1075-34	SMALL FIXED INDUCTOR (10NH)	C	R58			RK73GB1J474J	CHIP R 470K J 1/16W	
L16			L40-1075-92	SMALL FIXED INDUCTOR (10NH)		R59			R92-1252-05	CHIP R 0 OHM J 1/16W	
L17			L40-1875-92	SMALL FIXED INDUCTOR (18NH)		R60			RK73GB1J103J	CHIP R 10K J 1/16W	
L19			L34-4667-05	AIR-CORE COIL		R61			R92-2687-05	RESISTOR 5.6 J 5W	
L20			L34-4758-05	AIR-CORE COIL		R62			RK73GB1J103J	CHIP R 10K J 1/16W	
R1			RK73GB1J103J	CHIP R 10K J 1/16W		R70			R92-1252-05	CHIP R 0 OHM J 1/16W	
R2			RK73GB1J222J	CHIP R 2.2K J 1/16W	C	R71			R92-1214-05	CHIP R 120 J 1/2W	
R2			RK73GB1J472J	CHIP R 4.7K J 1/16W	C3,C6	R72			RK73GB1J184J	CHIP R 180K J 1/16W	
R3			RK73GB1J470J	CHIP R 47 J 1/16W		R73			R92-1204-05	CHIP R 100 J 1/4W	
R4			RK73GB1J100J	CHIP R 10 J 1/16W	C3,C6	R77			RK73GB1J154J	CHIP R 150K J 1/16W	
R4			RK73GB1J220J	CHIP R 22 J 1/16W	C	VR1			R12-6429-05	TRIMMING POT. (100K)	
R6			RK73GB1J100J	CHIP R 10 J 1/16W	C3,C6	K1			S76-0426-05	RELAY	
R6			RK73GB1J470J	CHIP R 47 J 1/16W	C	D2			O2DZ6.2(Y)	ZENER DIODE	
R7			RK73GB1J682J	CHIP R 6.8K J 1/16W		D4,5			HSM88AS	DIODE	
R8			RK73FB2A100J	CHIP R 10 J 1/10W		D7			ZSA5A27	ZENER DIODE	
R9			RK73FB2A220J	CHIP R 22 J 1/10W		D8			RB051L-40	DIODE	
R11			RK73GB1J104J	CHIP R 100K J 1/16W	C	D9			MINISMD C050-02	VARISTOR	
R11			RK73GB1J333J	CHIP R 33K J 1/16W	C3,C6	D10			1SS355	DIODE	
R12			RK73GB1J153J	CHIP R 15K J 1/16W	C3,C6	D51,52			DSA3A1	DIODE	
R12			RK73GB1J183J	CHIP R 18K J 1/16W	C	D53			MA4PH633	DIODE	
R13			RK73FB2A220J	CHIP R 22 J 1/10W	C3,C6	D55,56			MA4PH633	DIODE	
R13			RK73FB2A470J	CHIP R 47 J 1/10W	C	IC1			MAX6502UKP035	ANALOGUE IC	
R14			R92-0365-05	CHIP R 1.0K J 1/2W	C	IC2			NJM78L05UA	BI-POLAR IC	
R14			R92-0700-05	CHIP R 180 J 1/2W	C6	IC3			TA75W01FU	MOS-IC	
R14			R92-2571-05	CHIP R 270 J 1/2	C3	Q1			2SC5110(O)	TRANSISTOR	
R15			R92-0686-05	CHIP R 33 J 1/2W	C6	Q2			2SC3356(R24)	TRANSISTOR	
R15			R92-1211-05	CHIP R 5.6 J 1/2W	C	Q3			2SK2596	FET	
R15			R92-1259-05	CHIP R 18 J 1/2W	C3	Q4			PD55008S	DRIVE FET	
R16			R92-0365-05	CHIP R 1.0K J 1/2W	C	Q5			RD60HUF1-01	FINAL FET	
R16			R92-0700-05	CHIP R 180 J 1/2W	C6	Q8			2SC4116(Y)	TRANSISTOR	
R16			R92-2571-05	CHIP R 270 J 1/2	C3	Q9			DTD123EK	DIGITAL TRANSISTOR	
R17			RK73FB2A154J	CHIP R 150K J 1/10W		TH1			PTH9M04BE471TS	THERMISTOR	
R18			RK73EB2B101J	CHIP R 100 J 1/8W		DISPLAY UNIT (X54-3330-21)					
R19			RK73FB2A104J	CHIP R 100K J 1/10W		D503-505			B30-2151-05	LED (RED/GREEN)	
R20,21			R92-1252-05	CHIP R 0 OHM J 1/16W		C501			C92-0628-05	CHIP-TAN 10UF 10WV	
R22			R92-1215-05	CHIP R 470 J 1/2W		C502,503			C92-0501-05	CHIP-TAN 1.5UF 10WV	
R23,24			RK73FB2A104J	CHIP R 100K J 1/10W		C504,505			CK73GB1C104K	CHIP C 0.10UF K	
R26			RK73GB1J101J	CHIP R 100 J 1/16W		C506			CC73GCH1H470J	CHIP C 47PF J	
R31			RK73GB1J224J	CHIP R 220K J 1/16W		C507,508			CK73GB1C104K	CHIP C 0.10UF K	
R34			R92-1252-05	CHIP R 0 OHM J 1/16W		C509			CK73GB1H103K	CHIP C 0.010UF K	
R35			RK73GB1J104J	CHIP R 100K J 1/16W		C510			C92-0628-05	CHIP-TAN 10UF 10WV	
R36			R92-1252-05	CHIP R 0 OHM J 1/16W		C511,512			CK73GB1E103K	CHIP C 0.010UF K	
R37			R92-0670-05	CHIP R 0 OHM		C513-518			CC73GCH1H101J	CHIP C 100PF J	
R38			RK73GB1J473J	CHIP R 47K J 1/16W		C519,520			CK73GB1E103K	CHIP C 0.010UF K	
R40			R92-1204-05	CHIP R 100 J 1/4W		C521			C92-0628-05	CHIP-TAN 10UF 10WV	
R41,42			R92-1252-05	CHIP R 0 OHM J 1/16W		C522			CK73GB1C104K	CHIP C 0.10UF K	
R44			R92-0670-05	CHIP R 0 OHM		C523		*	CK73FB1E334K	CHIP C 0.33UF K	
R45			RK73GB1J223J	CHIP R 22K J 1/16W		C524			C92-0628-05	CHIP-TAN 10UF 10WV	
R46			RK73GB1J471J	CHIP R 470 J 1/16W	C	C525			CK73GB1C104K	CHIP C 0.10UF K	
R46			R92-1252-05	CHIP R 0 OHM J 1/16W	C3,C6	C526		*	CK73FB1E334K	CHIP C 0.33UF K	
R47			RK73GB1J222J	CHIP R 2.2K J 1/16W	C	C601			CC73GCH1H101J	CHIP C 100PF J	
R47			RK73GB1J332J	CHIP R 3.3K J 1/16W	C3,C6	C602			CK73GB1H102K	CHIP C 1000PF K	
R48			RK73GB1J471J	CHIP R 470 J 1/16W		C603			CC73GCH1H101J	CHIP C 100PF J	
R49			R92-1217-05	CHIP R 0 OHM							
R50			R92-1317-05	CHIP R 18 J 1W							
R54			RK73GB1J102J	CHIP R 1.0K J 1/16W							

PARTS LIST / 零件表

DISPLAY UNIT (X54-3330-21)
TX-RX UNIT (X57-696X-XX)

Ref. No.	Address	New parts	Parts No.	Description	Desti-nation	Ref. No.	Address	New parts	Parts No.	Description	Desti-nation
C606			CC73GCH1H101J	CHIP C 100PF J		C4,5			CK73GB1H471K	CHIP C 470PF K	
C607			CK73GB1C104K	CHIP C 0.10UF K		C7			CC73GCH1H080D	CHIP C 8.0PF D	C3
CN501			E40-6140-05	PIN ASSY		C7			CC73GCH1H120J	CHIP C 12PF J	C,C6
CN502			E40-6102-05	PIN ASSY		C8			CC73GCH1H0R5C	CHIP C 0.5PF C	C
CN601			E40-6141-05	PIN ASSY		C8			CC73GCH1H010C	CHIP C 1.0PF C	C3
J601			E08-0877-05	MODULAR JACK		C8			CC73GCH1H030C	CHIP C 3.0PF C	C6
-			J31-0543-05	COLLAR (LH-5-1.5)		C13			CK73GB1H471K	CHIP C 470PF K	
CP501-504			RK75GB1J471J	CHIP-COM 470 J 1/16W		C14,15			CC73GCH1H060D	CHIP C 6.0PF D	C
R502,503			R92-1252-05	CHIP R 0.OHM J 1/16W		C14,15			CC73GCH1H070D	CHIP C 7.0PF D	C3,C6
R505			RK73GB1J683J	CHIP R 68K J 1/16W		C24			C92-0695-05	CHIP-TAN 10UF 10WV	
R506			RK73GB1J103J	CHIP R 10K J 1/16W		C25			C92-0628-05	CHIP-TAN 10UF 10WV	
R507			RK73GB1J682J	CHIP R 6.8K J 1/16W		C28			CC73GCH1H080D	CHIP C 8.0PF D	C3,C6
R508			RK73GB1J102J	CHIP R 1.0K J 1/16W		C28,29			CC73GCH1H020C	CHIP C 2.0PF C	C
R509			RK73GB1J103J	CHIP R 10K J 1/16W		C29			CC73GCH1H110J	CHIP C 11PF J	C3
R510			RK73GB1J224J	CHIP R 220K J 1/16W		C29			CC73GCH1H120J	CHIP C 12PF J	C6
R511,512			RK73GB1J103J	CHIP R 10K J 1/16W		C30			CC73GCH1H680J	CHIP C 68PF J	
R513			RK73GB1J104J	CHIP R 100K J 1/16W		C31			CC73GCH1H331J	CHIP C 330PF J	
R514			RK73GB1J154J	CHIP R 150K J 1/16W		C32			CK73GB1H103K	CHIP C 0.010UF K	
R516			R92-2565-05	CHIP R 1.2K J 1/2W		C33			CC73GCH1H330J	CHIP C 33PF J	
R517			R92-2023-05	CHIP R 820 J 1/2W		C34			CK73GB1H103K	CHIP C 0.010UF K	
R518,519			R92-2565-05	CHIP R 1.2K J 1/2W		C36,37			CK73GB1H103K	CHIP C 0.010UF K	
R520-526			R92-2023-05	CHIP R 820 J 1/2W		C38,39			CC73GCH1H680J	CHIP C 68PF J	
R529-540			RK73GB1J102J	CHIP R 1.0K J 1/16W		C40,41			CK73GB1H103K	CHIP C 0.010UF K	
R541-544			RK73GB1J103J	CHIP R 10K J 1/16W		C42,43			CC73GCH1H030C	CHIP C 3.0PF C	
R601			RK73GB1J681J	CHIP R 680 J 1/16W		C44,45			CC73GCH1H040C	CHIP C 4.0PF C	
R604,605			RK73GB1J102J	CHIP R 1.0K J 1/16W		C46,47			CC73GCH1H030C	CHIP C 3.0PF C	
R606			RK73GB1J473J	CHIP R 47K J 1/16W		C48			CK73GB1H103K	CHIP C 0.010UF K	
VR501			R32-0643-05	SEMI FIXED VARIABLE RESISTOR		C49,50			CC73GCH1H680J	CHIP C 68PF J	
VR601			R31-0630-05	VARIABLE RESISTOR		C51			CK73GB1H103K	CHIP C 0.010UF K	
S501-506			S70-0410-15	TACT SWITCH		C52			CK73GB1H103J	CHIP C 0.010UF J	
S507			S68-0410-05	PUSH SWITCH		C53			CK73GB1H102K	CHIP C 1000PF K	
D501,502			HSM88AS	DIODE		C54			CK73GB1H103J	CHIP C 0.010UF J	
D506,507			LA-501DD	LED		C55,56			CK73GB1H103K	CHIP C 0.010UF K	
D508-514			DA204U	DIODE		C57			CK73GB1H103J	CHIP C 0.010UF J	
D601,602			DA204U	DIODE		C58			CC73GCH1H180J	CHIP C 18PF J	
D603			MINISMDC020	VARISTOR		C59			CC73GCH1H150J	CHIP C 15PF J	
IC501			NJM4558E	MOS-IC		C60			CK73GB1H103K	CHIP C 0.010UF K	
IC502-505			BU4094BCFV	MOS-IC		C61			CC73GCH1H080D	CHIP C 8.0PF D	
IC506,507			TA78L05F	MOS-IC		C62,63			CK73GB1H103K	CHIP C 0.010UF K	
Q501			2SC4116(Y)	TRANSISTOR		C64			CK73GB1C104K	CHIP C 0.10UF K	
Q502			2SA1586(Y,GR)	TRANSISTOR		C65			C92-0628-05	CHIP-TAN 10UF 10WV	
Q503,504			UPA672T	FET		C66,67			CC73GCH1H331J	CHIP C 330PF J	
Q506			DTA114EUA	DIGITAL TRANSISTOR		C68-70			CK73GB1C104K	CHIP C 0.10UF K	
Q507			UPA672T	FET		C71			CK73GB1H103K	CHIP C 0.010UF K	
Q508-511			DTA114EUA	DIGITAL TRANSISTOR		C72			C92-0628-05	CHIP-TAN 10UF 10WV	
Q512-514			UPA672T	FET		C73			CK73GB1C104K	CHIP C 0.10UF K	
Q516-519			UPA672T	FET		C74			CK73GB1H102K	CHIP C 1000PF K	
Q521-524			UPA672T	FET		C75			CK73GB1C104K	CHIP C 0.10UF K	
Q525			2SK1824	FET		C76			C92-0696-05	CHIP-TAN 47UF 10WV	
						C77			CK73GB1H102K	CHIP C 1000PF K	
						C78			CK73GB1C104K	CHIP C 0.10UF K	
						C79			CK73FB1C224K	CHIP C 0.22UF K	
						C80,81			C92-0628-05	CHIP-TAN 10UF 10WV	
						C82-84			CK73GB1H103K	CHIP C 0.010UF K	
						C86			CK73GB1H102K	CHIP C 1000PF K	
						C87			C92-0628-05	CHIP-TAN 10UF 10WV	
						C88			CK73GB1H102K	CHIP C 1000PF K	
						C89,90			CK73GB1H103J	CHIP C 0.010UF J	
						C91			CC73GCH1H040C	CHIP C 4.0PF C	C,C6
						C91			CC73GCH1H050C	CHIP C 5.0PF C	C3
TX-RX UNIT (X57-696X-XX) 0-11 : C 0-13 : C3 3-01 : C6											
C2			CC73GCH1H010C	CHIP C 1.0PF C	C3						
C2			CC73GCH1H020C	CHIP C 2.0PF C	C6						
C3			CC73GCH1H090D	CHIP C 9.0PF D	C6						
C3			CC73GCH1H100D	CHIP C 10PF D	C3						
C3			CC73GCH1H120J	CHIP C 12PF J	C						

PARTS LIST / 零件表

TX-RX UNIT (X57-696X-XX)

Ref. No.	Address	New parts	Parts No.	Description	Destination	Ref. No.	Address	New parts	Parts No.	Description	Destination
C92,93			CK73GB1H471K	CHIP C 470PF K		C178			C92-0606-05	CHIP-TAN 4.7UF 10WV	
C94			CC73GCH1H030C	CHIP C 3.0PF C	C	C179			CK73GB1H103K	CHIP C 0.010UF K	
C94			CC73GCH1H050C	CHIP C 5.0PF C	C6	C184,185			CK73GB1H102K	CHIP C 1000PF K	
C94,95			CC73GCH1H040C	CHIP C 4.0PF C	C3	C189,190			CK73GB1H102K	CHIP C 1000PF K	
C95			CC73GCH1H040C	CHIP C 4.0PF C	C	C191-195			CK73GB1H103K	CHIP C 0.010UF K	
C95			CC73GCH1H060D	CHIP C 6.0PF D	C6	C197			CK73FB1H333K	CHIP C 0.033UF K	
C96-99			CK73GB1H471K	CHIP C 470PF K		C198			CK73GB1C104K	CHIP C 0.10UF K	
C100			CC73GCH1H060D	CHIP C 6.0PF D	C3	C199			CK73GB1H103K	CHIP C 0.010UF K	
C100			CC73GCH1H070D	CHIP C 7.0PF D	C6	C204-208			CC73GCH1H101J	CHIP C 100PF J	
C100,101			CC73GCH1H050C	CHIP C 5.0PF C	C	C210			CC73GCH1H080D	CHIP C 8.0PF D	C
C101			CC73GCH1H050C	CHIP C 5.0PF C	C3,C6	C210			CC73GCH1H100D	CHIP C 10PF D	C3
C102			CK73GB1H471K	CHIP C 470PF K		C210			CC73GCH1H120J	CHIP C 12PF J	C6
C104			CK73GB1H471K	CHIP C 470PF K		C211			CC73GCH1H120J	CHIP C 12PF J	C
C105			CC73GCH1H070D	CHIP C 7.0PF D		C212-214			CK73GB1H103K	CHIP C 0.010UF K	
C106			CK73GB1H471K	CHIP C 470PF K		C216			CK73GB1H471K	CHIP C 470PF K	
C107			CC73GCH1H060D	CHIP C 6.0PF D	C,C3	C217			CK73GB1H102K	CHIP C 1000PF K	
C107			CC73GCH1H080D	CHIP C 8.0PF D	C6	C218			CK73GB1E103K	CHIP C 0.010UF K	
C109			CC73GCH1H120J	CHIP C 12PF J	C,C3	C223			CC73GCH1H101J	CHIP C 100PF J	C
C109			CC73GCH1H180J	CHIP C 18PF J	C6	C224			CC73GCH1H030C	CHIP C 3.0PF C	C3
C111			CC73GCH1H060D	CHIP C 6.0PF D	C,C3	C224			CC73GCH1H050C	CHIP C 5.0PF C	C6
C111			CC73GCH1H080D	CHIP C 8.0PF D	C6	C225			CC73GCH1H020C	CHIP C 2.0PF C	C6
C114-117			CC73GCH1H100D	CHIP C 10PF D		C231			C92-0633-05	CHIP-TAN 22UF 10WV	
C120,121			CK73GB1H471K	CHIP C 470PF K		C232-234			CK73GB1H103J	CHIP C 0.010UF J	
C122,123			CK73GB1H103K	CHIP C 0.010UF K		C235			CC73GCH1H101J	CHIP C 100PF J	C3
C124,125			C92-1341-05	ELECTRO 100UF 16WV		C251			CC73GCH1H030C	CHIP C 3.0PF C	C3,C6
C126,127			C92-0633-05	CHIP-TAN 22UF 10WV		C600			CK73GB1C104K	CHIP C 0.10UF K	
C128,129			CK73GB1H103K	CHIP C 0.010UF K		C602			CK73GB1C104K	CHIP C 0.10UF K	
C130,131			CK73GB1H102K	CHIP C 1000PF K		C605			CK73GB1C104K	CHIP C 0.10UF K	
C132,133			CK73GB1H471K	CHIP C 470PF K		C613,614			CK73GB1E103K	CHIP C 0.010UF K	
C134,135			CK73GB1H103K	CHIP C 0.010UF K		C616			CK73GB1E103K	CHIP C 0.010UF K	
C136-139			C90-4016-05	ELECTRO 47UF 16WV		C623			CK73GB1C104K	CHIP C 0.10UF K	
C140,141			CK73GB1H103K	CHIP C 0.010UF K		C629			CC73GCH1H101J	CHIP C 100PF J	
C142,143			CK73GB1H102K	CHIP C 1000PF K		C634,635			CC73GCH1H220J	CHIP C 22PF J	
C144			CK73GB1H471K	CHIP C 470PF K		C638			CK73GB1C104K	CHIP C 0.10UF K	
C145			C92-0606-05	CHIP-TAN 4.7UF 10WV		C639			CK73GB1E103K	CHIP C 0.010UF K	
C146			CK73GB1H471K	CHIP C 470PF K		C640			C92-0628-05	CHIP-TAN 10UF 10WV	
C147			C92-0633-05	CHIP-TAN 22UF 10WV		C641			CK73GB1C104K	CHIP C 0.10UF K	
C148			CK73GB1H102K	CHIP C 1000PF K		C642			CK73GB1E103K	CHIP C 0.010UF K	
C149			CK73GB1H103K	CHIP C 0.010UF K		C643			C92-0628-05	CHIP-TAN 10UF 10WV	
C150			C92-0633-05	CHIP-TAN 22UF 10WV		C644			CK73GB1E103K	CHIP C 0.010UF K	
C151			C92-0008-05	CHIP-TAN 3.3UF 16WV		C645,646			C92-0628-05	CHIP-TAN 10UF 10WV	
C152			CK73GB1H103K	CHIP C 0.010UF K		C647			CC73GCH1H101J	CHIP C 100PF J	
C153			CK73GB1H471K	CHIP C 470PF K		C648			CK73GB1E103K	CHIP C 0.010UF K	
C154			C92-0560-05	CHIP-TAN 10UF 6.3WV		C649			CC73GCH1H330J	CHIP C 33PF J	
C155			CK73GB1H103K	CHIP C 0.010UF K		C652			CC73GCH1H101J	CHIP C 100PF J	
C156			CK73GB1H102K	CHIP C 1000PF K		C657			CK73GB1E103K	CHIP C 0.010UF K	
C157			CK73GB1H103K	CHIP C 0.010UF K		C662			C92-0628-05	CHIP-TAN 10UF 10WV	
C158			C92-0008-05	CHIP-TAN 3.3UF 16WV		C663			C92-0519-05	CHIP-TAN 1.0UF 25WV	
C159			CK73GB1H471K	CHIP C 470PF K		C670			C92-0003-05	CHIP-TAN 0.47UF 25WV	
C160			CK73GB1H102K	CHIP C 1000PF K		C679			C92-0628-05	CHIP-TAN 10UF 10WV	
C161-163			CK73GB1H103K	CHIP C 0.010UF K		C681			C92-0546-05	CHIP-TAN 68UF 6.3WV	
C164			CK73GB1H471K	CHIP C 470PF K		C684			CC73GCH1H101J	CHIP C 100PF J	
C166,167			CK73GB1H471K	CHIP C 470PF K		C685			CK73GB1E103K	CHIP C 0.010UF K	
C171			CK73GB1H471K	CHIP C 470PF K		C690			CC73GCH1H101J	CHIP C 100PF J	
C172			CK73GB1H102K	CHIP C 1000PF K		C691,692			CK73GB1E103K	CHIP C 0.010UF K	
C173			CK73GB1H103K	CHIP C 0.010UF K		C693,694			C92-0628-05	CHIP-TAN 10UF 10WV	
C174			C92-0008-05	CHIP-TAN 3.3UF 16WV		C695,696			CK73GB1H471K	CHIP C 470PF K	
C175			CK73GB1H102K	CHIP C 1000PF K		C697,698			C92-0628-05	CHIP-TAN 10UF 10WV	
C176			CK73GB1H103K	CHIP C 0.010UF K		C700,701			C92-0628-05	CHIP-TAN 10UF 10WV	
C177			CK73GB1H471K	CHIP C 470PF K		C703,704			CK73GB1C104K	CHIP C 0.10UF K	

PARTS LIST / 零件表

TX-RX UNIT (X57-696X-XX)

Ref. No.	Address	New parts	Parts No.	Description	Destination	Ref. No.	Address	New parts	Parts No.	Description	Destination
C705			CK73GB1E103K	CHIP C 0.010UF K		C792-794			CK73GB1H102K	CHIP C 1000PF K	
C706			C92-0628-05	CHIP-TAN 10UF 10WV		C795			CC73GCH1H101J	CHIP C 100PF J	
C707-709			CK73GB1E103K	CHIP C 0.010UF K		C796,797			CK73GB1H102K	CHIP C 1000PF K	
C710			C92-0628-05	CHIP-TAN 10UF 10WV		C798			CE04EW1E470M	ELECTRO 47UF 25WV	
C711			CK73GB1H471K	CHIP C 470PF K		C799			CK73GB1H102K	CHIP C 1000PF K	
C712			CK73GB1E103K	CHIP C 0.010UF K		C800			CE04EW1E470M	ELECTRO 47UF 25WV	
C713,714			C92-0628-05	CHIP-TAN 10UF 10WV		C801			C92-0560-05	CHIP-TAN 10UF 6.3WV	
C715			CK73GB1E103K	CHIP C 0.010UF K		C802-805			CK73GB1H102K	CHIP C 1000PF K	
C716,717			CK73GB1H471K	CHIP C 470PF K		C806			CE04EW1E470M	ELECTRO 47UF 25WV	
C718,719			CK73GB1E103K	CHIP C 0.010UF K		C807-810			CK73GB1H102K	CHIP C 1000PF K	
C720			C92-0532-05	CHIP-TAN 1.0UF 10WV		C811			CE04EW1E470M	ELECTRO 47UF 25WV	
C721,722			C92-0628-05	CHIP-TAN 10UF 10WV		C812,813			CK73GB1H102K	CHIP C 1000PF K	
C723			CK73FB1C105K	CHIP C 1.0UF K		C814			C92-0777-05	ELECTRO 1000UF 25WV	
C724			CK73GB1H182K	CHIP C 1800PF K		C815			CK73FB1E104K	CHIP C 0.10UF K	
C725			CC73GCH1H470J	CHIP C 47PF J		C816			CK73GB1H102K	CHIP C 1000PF K	
C726			CC73GCH1H181J	CHIP C 180PF J		C817			CE04EW1E470M	ELECTRO 47UF 25WV	
C727,728			CK73GB1E103K	CHIP C 0.010UF K		C818-820			CK73GB1H102K	CHIP C 1000PF K	
C729			C92-0628-05	CHIP-TAN 10UF 10WV		C821,822			CC73GCH1H101J	CHIP C 100PF J	
C730,731			CK73GB1E103K	CHIP C 0.010UF K		C823			C92-0619-05	CHIP-TAN 47UF 4WV	
C732			CK73GB1H471K	CHIP C 470PF K		C824			CK73GB1H472K	CHIP C 4700PF K	
C733			C92-0628-05	CHIP-TAN 10UF 10WV		C825			CK73GB1C104K	CHIP C 0.10UF K	
C734			CC73GCH1H270J	CHIP C 27PF J		C826			C92-0560-05	CHIP-TAN 10UF 6.3WV	
C735			CC73GCH1H150J	CHIP C 15PF J		C827			C92-0823-05	CHIP-TAN 100UF 10WV	
C736			CK73GB1H182K	CHIP C 1800PF K		C828			C92-0514-05	CHIP-TAN 2.2UF 10WV	
C737			CC73GCH1H270J	CHIP C 27PF J		C829			CK73GB1C104K	CHIP C 0.10UF K	
C738			CK73GB1E103K	CHIP C 0.010UF K		C830			CK73GB1E103K	CHIP C 0.010UF K	
C739			CC73GCH1H181J	CHIP C 180PF J		C831			CK73GB1H102K	CHIP C 1000PF K	
C740			CC73GCH1H101J	CHIP C 100PF J		C832,833			CK73GB1E103K	CHIP C 0.010UF K	
C741			CK73GB1E103K	CHIP C 0.010UF K		C834,835			CK73GB1C104K	CHIP C 0.10UF K	
C742			CK73GB1H471K	CHIP C 470PF K		C836-838			CK73GB1E103K	CHIP C 0.010UF K	
C743			CK73GB1E103K	CHIP C 0.010UF K		C839			CK73GB1H271K	CHIP C 270PF K	
C744-746			C92-0628-05	CHIP-TAN 10UF 10WV		C840			CK73GB1H472K	CHIP C 4700PF K	
C747,748			CK73GB1E103K	CHIP C 0.010UF K		C841			CK73FB1C105K	CHIP C 1.0UF K	
C749			CK73GB1H471K	CHIP C 470PF K		C842			C92-0519-05	CHIP-TAN 1.0UF 25WV	
C750,751			CK73GB1E103K	CHIP C 0.010UF K		C843,844			CK73GB1C104K	CHIP C 0.10UF K	
C752			CK73GB1H471K	CHIP C 470PF K		C851			CK73GB1C104K	CHIP C 0.10UF K	
C753,754			C92-0628-05	CHIP-TAN 10UF 10WV		C852			CK73GB1H102K	CHIP C 1000PF K	
C755			CK73GB1H471K	CHIP C 470PF K		CN1			E04-0154-05	PIN SOCKET	
C756,757			C92-0628-05	CHIP-TAN 10UF 10WV		CN2			E40-5538-05	PIN ASSY	
C758			CK73FB1C105K	CHIP C 1.0UF K		CN3			E04-0154-05	PIN SOCKET	
C759			CK73GB1H471K	CHIP C 470PF K		CN4			E40-5538-05	PIN ASSY	
C760			CK73GB1H102K	CHIP C 1000PF K		CN14			E40-6009-05	FLAT CABLE CONNECTOR	
C761			CK73GB1C104K	CHIP C 0.10UF K		CN15			E40-5703-05	PIN ASSY	
C762,763			CK73GB1H102K	CHIP C 1000PF K		CN16			E40-5632-05	PIN ASSY	
C764,765			CK73GB1E103K	CHIP C 0.010UF K		CN18,19			E04-0154-05	PIN SOCKET	
C766-768			CC73GCH1H101J	CHIP C 100PF J		CN600			E40-6102-05	PIN ASSY	
C769-771			C92-0560-05	CHIP-TAN 10UF 6.3WV		CN601			E40-5701-05	PIN ASSY	
C772			C92-0823-05	CHIP-TAN 100UF 10WV		CN602			E40-6009-05	FLAT CABLE CONNECTOR	
C773			C92-0514-05	CHIP-TAN 2.2UF 10WV		CN603			E40-5887-05	PIN ASSY	
C774			CK73FB1C105K	CHIP C 1.0UF K		CN604			E40-5702-05	PIN ASSY	
C775-779			C92-0519-05	CHIP-TAN 1.0UF 25WV		CN605			E40-5704-05	PIN ASSY	
C780-782			CK73FB1C105K	CHIP C 1.0UF K		CN606			E40-5960-05	PIN ASSY	
C783			CK73GB1H471K	CHIP C 470PF K		F1			F53-0217-05	FUSE	
C784			CK73FB1C105K	CHIP C 1.0UF K		CF1			L72-0366-05	CERAMIC FILTER	
C785,786			CK73GB1C104K	CHIP C 0.10UF K		CF2			L72-0376-05	CERAMIC FILTER	
C787			CK73FB1C105K	CHIP C 1.0UF K		L1			L34-4616-05	AIR-CORE COIL	
C788			CC73GCH1H101J	CHIP C 100PF J		L2			L79-1849-05	HELICAL BLOCK	
C789			CE04EW1E331M	ELECTRO 330UF 25WV		L2		*	L79-1851-05	HELICAL BLOCK	C C6
C790			CC73GCH1H101J	CHIP C 100PF J							
C791			CK73GB1H471K	CHIP C 470PF K							

PARTS LIST / 零件表

TX-RX UNIT (X57-696X-XX)

Ref. No.	Address	New parts	Parts No.	Description	Destination	Ref. No.	Address	New parts	Parts No.	Description	Destination
L2		*	L79-1853-05	HELICAL BLOCK	C3	CP610,611			R90-0750-05	CHIP COM 10 J 1/16W	
L3			L40-1575-34	SMALL FIXED INDUCTOR (15NH)	C3	CP612-614			R90-0725-05	MULTI-COMP 1K X2	
L3			L40-1875-34	SMALL FIXED INDUCTOR (18NH)	C	CP615-619			R90-0750-05	CHIP COM 10 J 1/16W	
L3			L40-2275-34	SMALL FIXED INDUCTOR (22NH)	C6	CP620			R90-1019-05	MULTI-COMP 100 X2	
L4,5			L79-1849-05	HELICAL BLOCK	C	R2			RK73GB1J122J	CHIP R 1.2K J 1/16W	
L4,5		*	L79-1851-05	HELICAL BLOCK	C6	R3			RK73GB1J102J	CHIP R 1.0K J 1/16W	
L4,5		*	L79-1853-05	HELICAL BLOCK	C3	R5			RK73GB1J101J	CHIP R 100 J 1/16W	
L6			L40-1875-34	SMALL FIXED INDUCTOR (18NH)	C	R8			RK73GB1J151J	CHIP R 150 J 1/16W	
L6			L40-2275-34	SMALL FIXED INDUCTOR (22NH)	C3,C6	R9			RK73GB1J223J	CHIP R 22K J 1/16W	
L10			L40-1581-37	SMALL FIXED INDUCTOR (0.150UH)		R10			RK73GB1J180J	CHIP R 18 J 1/16W	
L11			L40-1885-34	SMALL FIXED INDUCTOR (180NH)		R11			RK73GB1J271J	CHIP R 270 J 1/16W	
L12			L40-3381-37	SMALL FIXED INDUCTOR (0.330UH)		R13			RK73GB1J271J	CHIP R 270 J 1/16W	
L13			L40-1005-34	SMALL FIXED INDUCTOR (10UH)		R14			RK73GB1J333J	CHIP R 33K J 1/16W	
L14			L34-4527-05	COIL		R17			RK73GB1J824J	CHIP R 820K J 1/16W	
L15			L34-4526-05	COIL		R18			RK73GB1J684J	CHIP R 680K J 1/16W	
L16			L34-4527-05	COIL		R19			RK73GB1J474J	CHIP R 470K J 1/16W	
L17,18			L34-4526-05	COIL		R20			RK73GB1J184J	CHIP R 180K J 1/16W	C6
L19			L34-4527-05	COIL		R20			RK73GB1J224J	CHIP R 220K J 1/16W	C,C3
L20			L40-1095-34	SMALL FIXED INDUCTOR (1UH)		R30			RK73GB1J821J	CHIP R 820 J 1/16W	
L21			L40-1005-34	SMALL FIXED INDUCTOR (10UH)		R31			RK73GB1J5R6J	CHIP R 5.6 J 1/16W	
L23			L40-1095-34	SMALL FIXED INDUCTOR (1UH)		R32			RK73GB1J821J	CHIP R 820 J 1/16W	
L24			L34-4459-05	COIL		R33			RK73GB1J470J	CHIP R 47 J 1/16W	
L25			L40-2775-34	SMALL FIXED INDUCTOR (27NH)	C,C3	R34			RK73GB1J102J	CHIP R 1.0K J 1/16W	
L25,26			L40-3375-34	SMALL FIXED INDUCTOR (33NH)	C6	R35			RK73GB1J182J	CHIP R 1.8K J 1/16W	
L26			L40-1575-34	SMALL FIXED INDUCTOR (15NH)	C	R36			RK73GB1J102J	CHIP R 1.0K J 1/16W	
L26-28			L40-2275-34	SMALL FIXED INDUCTOR (22NH)	C3	R37			RK73GB1J682J	CHIP R 6.8K J 1/16W	
L27			L40-2275-34	SMALL FIXED INDUCTOR (22NH)	C	R38			R92-1252-05	CHIP R 0 OHM J 1/16W	
L27,28			L40-2775-34	SMALL FIXED INDUCTOR (27NH)	C6	R39			RK73GB1J560J	CHIP R 56 J 1/16W	
L28			L40-1875-34	SMALL FIXED INDUCTOR (18NH)	C	R40			RK73GB1J270J	CHIP R 27 J 1/16W	
L29,30			L40-1875-92	SMALL FIXED INDUCTOR (18NH)	C	R41			RK73GB1J222J	CHIP R 2.2K J 1/16W	
L29,30			L40-2275-92	SMALL FIXED INDUCTOR (22NH)	C3,C6	R42-45			RK73GB1J223J	CHIP R 22K J 1/16W	
L31,32			L40-1005-34	SMALL FIXED INDUCTOR (10UH)		R46			RK73GB1J222J	CHIP R 2.2K J 1/16W	
L33			L40-1575-92	SMALL FIXED INDUCTOR (15NH)	C	R47			RK73GB1J153J	CHIP R 15K J 1/16W	
L33			L40-1875-92	SMALL FIXED INDUCTOR (18NH)	C6	R48			RK73GB1J473J	CHIP R 47K J 1/16W	
L33			L40-2275-92	SMALL FIXED INDUCTOR (22NH)	C3	R49			RK73GB1J221J	CHIP R 220 J 1/16W	
L34			L40-1005-34	SMALL FIXED INDUCTOR (10UH)		R50			RK73GB1J153J	CHIP R 15K J 1/16W	
L35-39			L92-0140-05	CHIP FERRITE		R51			R92-1252-05	CHIP R 0 OHM J 1/16W	
L40			L92-0158-05	CHIP FERRITE		R52			RK73GB1J223J	CHIP R 22K J 1/16W	
L42			L40-1875-92	SMALL FIXED INDUCTOR (18NH)	C3	R53			RK73GB1J682J	CHIP R 6.8K J 1/16W	
L42			L40-2275-92	SMALL FIXED INDUCTOR (22NH)	C6	R54			RK73GB1J102J	CHIP R 1.0K J 1/16W	
L42			L40-6865-92	SMALL FIXED INDUCTOR (6.8NH)	C	R55			RK73GB1J223J	CHIP R 22K J 1/16W	
L43			L92-0140-05	CHIP FERRITE		R56			RK73GB1J682J	CHIP R 6.8K J 1/16W	
L45			L40-1875-92	SMALL FIXED INDUCTOR (18NH)	C3	R57			RK73GB1J332J	CHIP R 3.3K J 1/16W	
L45			L40-2275-92	SMALL FIXED INDUCTOR (22NH)	C6	R58			RK73GB1J153J	CHIP R 15K J 1/16W	
L46			L40-1575-34	SMALL FIXED INDUCTOR (15NH)	C6	R60			RK73GB1J103J	CHIP R 10K J 1/16W	
L600-608			L92-0140-05	CHIP FERRITE		R61			RK73GB1J274J	CHIP R 270K J 1/16W	
L611-613			L92-0140-05	CHIP FERRITE		R62			RK73GB1J222J	CHIP R 2.2K J 1/16W	
X1			L77-1762-05	CRYSTAL RESONATOR (44.395MHZ)		R63			RK73GB1J183J	CHIP R 18K J 1/16W	
X2,3			L77-1849-05	VCXO (16.8MHZ/1.5PP)		R65			RK73GB1J472J	CHIP R 4.7K J 1/16W	
X600			L78-0431-05	RESONATOR (14.7456MHZ)		R66			RK73GB1J334J	CHIP R 330K J 1/16W	
X601			L77-1799-05	CRYSTAL RESONATOR (16.515MHZ)		R67			RK73GB1J560J	CHIP R 56 J 1/16W	
XF1			L71-0513-05	MCF (44.85MHZ NARROW)		R68,69			RK73GB1J332J	CHIP R 3.3K J 1/16W	
XF2			L71-0512-05	MCF (44.85MHZ WIDE)		R70			RK73GB1J102J	CHIP R 1.0K J 1/16W	
CP600,601			R90-0725-05	MULTI-COMP 1K X2		R71			RK73GB1J823J	CHIP R 82K J 1/16W	
CP603			R90-1019-05	MULTI-COMP 100 X2		R72			RK73GB1J334J	CHIP R 330K J 1/16W	
CP604,605			R90-0725-05	MULTI-COMP 1K X2		R73			RK73GB1J474J	CHIP R 470K J 1/16W	
CP606			R90-0719-05	MULTI-COMP 4.7K X2		R74,75			RK73GB1J220J	CHIP R 22 J 1/16W	
CP607,608			R90-0725-05	MULTI-COMP 1K X2		R76			RK73GB1J104J	CHIP R 100K J 1/16W	
CP609			R90-1019-05	MULTI-COMP 100 X2		R77,78			RK73GB1J473J	CHIP R 47K J 1/16W	
						R79			RK73GB1J104J	CHIP R 100K J 1/16W	

PARTS LIST / 零件表

TX-RX UNIT (X57-696X-XX)

Ref. No.	Address	New parts	Parts No.	Description	Desti-nation	Ref. No.	Address	New parts	Parts No.	Description	Desti-nation
R82			RK73GB1J474J	CHIP R 470K J 1/16W		R600			RK73GB1J473J	CHIP R 47K J 1/16W	
R83			R92-1252-05	CHIP R 0 OHM J 1/16W		R601			R92-0670-05	CHIP R 0 OHM	
R87,88			RK73GB1J102J	CHIP R 1.0K J 1/16W		R602			RK73GB1J472J	CHIP R 4.7K J 1/16W	
R90			R92-1252-05	CHIP R 0 OHM J 1/16W		R603			RK73GB1J102J	CHIP R 1.0K J 1/16W	
R91			RK73GB1J472J	CHIP R 4.7K J 1/16W		R604			RK73GB1J333J	CHIP R 33K J 1/16W	
R92			RK73GB1J182J	CHIP R 1.8K J 1/16W		R605			RK73GB1J104J	CHIP R 100K J 1/16W	
R93,94			RK73GB1J101J	CHIP R 100 J 1/16W		R606			RK73GB1J473J	CHIP R 47K J 1/16W	
R95			RK73GB1J472J	CHIP R 4.7K J 1/16W		R607-613			R92-1252-05	CHIP R 0 OHM J 1/16W	
R96			RK73GB1J182J	CHIP R 1.8K J 1/16W		R614			RK73GB1J473J	CHIP R 47K J 1/16W	
R97			RK73GB1J332J	CHIP R 3.3K J 1/16W		R615			R92-1252-05	CHIP R 0 OHM J 1/16W	
R98			RK73GB1J102J	CHIP R 1.0K J 1/16W		R616			RK73GB1J473J	CHIP R 47K J 1/16W	
R99			RK73GB1J101J	CHIP R 100 J 1/16W		R618			R92-1252-05	CHIP R 0 OHM J 1/16W	
R100			RK73GB1J680J	CHIP R 68 J 1/16W		R619			RK73GB1J473J	CHIP R 47K J 1/16W	
R101			RK73GB1J470J	CHIP R 47 J 1/16W		R620-622			RK73GB1J102J	CHIP R 1.0K J 1/16W	
R102			RK73GB1J332J	CHIP R 3.3K J 1/16W		R623,624			R92-1252-05	CHIP R 0 OHM J 1/16W	
R103			RK73GB1J102J	CHIP R 1.0K J 1/16W		R625-627			RK73GB1J102J	CHIP R 1.0K J 1/16W	
R105			RK73GB1J270J	CHIP R 27 J 1/16W		R629			R92-1252-05	CHIP R 0 OHM J 1/16W	
R106			R92-1252-05	CHIP R 0 OHM J 1/16W		R630,631			RK73GB1J473J	CHIP R 47K J 1/16W	
R107			RK73GB1J470J	CHIP R 47 J 1/16W		R633,634			RK73GB1J473J	CHIP R 47K J 1/16W	
R109			RK73GB1J101J	CHIP R 100 J 1/16W		R635			RK73GB1J102J	CHIP R 1.0K J 1/16W	
R113			RK73GB1J471J	CHIP R 470 J 1/16W		R637			R92-1252-05	CHIP R 0 OHM J 1/16W	
R114			R92-1252-05	CHIP R 0 OHM J 1/16W	C,C3	R638			RK73GB1J102J	CHIP R 1.0K J 1/16W	
R120,121			RK73GB1J152J	CHIP R 1.5K J 1/16W		R639			R92-1252-05	CHIP R 0 OHM J 1/16W	
R122,123			RK73GB1J100J	CHIP R 10 J 1/16W		R640			RK73GB1J102J	CHIP R 1.0K J 1/16W	
R124,125			RK73GB1J152J	CHIP R 1.5K J 1/16W		R641			R92-1252-05	CHIP R 0 OHM J 1/16W	
R126,127			RK73GB1J100J	CHIP R 10 J 1/16W		R642			RK73GB1J102J	CHIP R 1.0K J 1/16W	
R128			RK73GB1J472J	CHIP R 4.7K J 1/16W		R643			RK73GB1J473J	CHIP R 47K J 1/16W	
R129,130			RK73GB1J473J	CHIP R 47K J 1/16W		R644			RK73GB1J102J	CHIP R 1.0K J 1/16W	
R131			RK73GB1J102J	CHIP R 1.0K J 1/16W		R645,646			RK73GB1J473J	CHIP R 47K J 1/16W	
R134			RK73GB1J821J	CHIP R 820 J 1/16W		R647,648			RK73GB1J101J	CHIP R 100 J 1/16W	
R135			RK73GB1J5R6J	CHIP R 5.6 J 1/16W		R649-651			RK73GB1J102J	CHIP R 1.0K J 1/16W	
R136			RK73GB1J821J	CHIP R 820 J 1/16W		R652			RK73GB1J101J	CHIP R 100 J 1/16W	
R137,138			RK73GB1J102J	CHIP R 1.0K J 1/16W		R653,654			R92-0670-05	CHIP R 0 OHM	
R139-142			R92-1252-05	CHIP R 0 OHM J 1/16W		R655			RK73GB1J473J	CHIP R 47K J 1/16W	
R143			RK73GB1J102J	CHIP R 1.0K J 1/16W		R656			RK73GB1J102J	CHIP R 1.0K J 1/16W	
R144			RK73GB1J472J	CHIP R 4.7K J 1/16W		R657-661			RK73GB1J473J	CHIP R 47K J 1/16W	
R145			RK73FB2A470J	CHIP R 47 J 1/10W		R662			RK73GB1J102J	CHIP R 1.0K J 1/16W	
R148			RK73GB1J472J	CHIP R 4.7K J 1/16W		R663-667			RK73GB1J473J	CHIP R 47K J 1/16W	
R150			RK73GB1J180J	CHIP R 18 J 1/16W		R668			RK73GB1J183J	CHIP R 18K J 1/16W	
R151-158			RK73GB1J102J	CHIP R 1.0K J 1/16W		R669-671			RK73GB1J223J	CHIP R 22K J 1/16W	
R160,161			RK73GB1J471J	CHIP R 470 J 1/16W		R672			RK73GB1J104J	CHIP R 100K J 1/16W	
R162-164			RK73GB1J271J	CHIP R 270 J 1/16W		R673			RK73GB1J224J	CHIP R 220K J 1/16W	
R165			RK73GB1J471J	CHIP R 470 J 1/16W		R674			RK73GB1J823J	CHIP R 82K J 1/16W	
R166			RK73GB1J223J	CHIP R 22K J 1/16W		R675			RK73GB1J104J	CHIP R 100K J 1/16W	
R168			RK73GB1J181J	CHIP R 180 J 1/16W	C6	R676			RK73GB1J823J	CHIP R 82K J 1/16W	
R168			RK73GB1J271J	CHIP R 270 J 1/16W	C3	R678			RK73GB1J104J	CHIP R 100K J 1/16W	
R168			R92-1252-05	CHIP R 0 OHM J 1/16W	C	R679,680			RK73GB1J223J	CHIP R 22K J 1/16W	
R169			RK73GB1J392J	CHIP R 3.9K J 1/16W		R681			RK73GB1J183J	CHIP R 18K J 1/16W	
R171			R92-1252-05	CHIP R 0 OHM J 1/16W		R682			RK73GB1J153J	CHIP R 15K J 1/16W	
R173			R92-1252-05	CHIP R 0 OHM J 1/16W	C6	R683			RK73GB1J124J	CHIP R 120K J 1/16W	
R173,174			R92-1252-05	CHIP R 0 OHM J 1/16W	C3	R684			RK73GB1J473J	CHIP R 47K J 1/16W	
R174			RK73GB1J151J	CHIP R 150 J 1/16W	C6	R685,686			RK73GB1J104J	CHIP R 100K J 1/16W	
R174,175			R92-1252-05	CHIP R 0 OHM J 1/16W	C	R687			RK73GB1J223J	CHIP R 22K J 1/16W	
R175			RK73GB1J331J	CHIP R 330 J 1/16W	C6	R688-690			RK73GB1J473J	CHIP R 47K J 1/16W	
R175			RK73GB1J391J	CHIP R 390 J 1/16W	C3	R691-693			R92-1252-05	CHIP R 0 OHM J 1/16W	
R176			RK73GB1J473J	CHIP R 47K J 1/16W		R694,695			RK73GB1J101J	CHIP R 100 J 1/16W	
R178			R92-1252-05	CHIP R 0 OHM J 1/16W	C3,C6	R696			RK73GB1J103J	CHIP R 10K J 1/16W	
R178,179			R92-1252-05	CHIP R 0 OHM J 1/16W	C	R697			RK73GB1J101J	CHIP R 100 J 1/16W	
R181			RK73GB1J182J	CHIP R 1.8K J 1/16W		R698			RK73GB1J103J	CHIP R 10K J 1/16W	
R182			R92-1252-05	CHIP R 0 OHM J 1/16W		R699			R92-1252-05	CHIP R 0 OHM J 1/16W	

PARTS LIST / 零件表

TX-RX UNIT (X57-696X-XX)

Ref. No.	Address	New parts	Parts No.	Description	Destination	Ref. No.	Address	New parts	Parts No.	Description	Destination
R700			RK73GB1J101J	CHIP R 100 J 1/16W		R786			RK73GB1J473J	CHIP R 47K J 1/16W	
R701			R92-1252-05	CHIP R 0 OHM J 1/16W		R787			RK73GB1J102J	CHIP R 1.0K J 1/16W	
R702			RK73GB1J473J	CHIP R 47K J 1/16W		R789			RK73GB1J102J	CHIP R 1.0K J 1/16W	
R703			R92-1252-05	CHIP R 0 OHM J 1/16W		R790			RK73GB1J473J	CHIP R 47K J 1/16W	
R704,705			RK73GB1J473J	CHIP R 47K J 1/16W		R791			RK73GB1J102J	CHIP R 1.0K J 1/16W	
R707-709			RK73GB1J223J	CHIP R 22K J 1/16W		R793			RK73GB1J102J	CHIP R 1.0K J 1/16W	
R710			RK73GB1J473J	CHIP R 47K J 1/16W		R794			RK73GB1J473J	CHIP R 47K J 1/16W	
R712			RK73GB1J473J	CHIP R 47K J 1/16W		R795			RK73GB1J102J	CHIP R 1.0K J 1/16W	
R713			RK73GB1J273J	CHIP R 27K J 1/16W		R798			RK73GB1J473J	CHIP R 47K J 1/16W	
R714			RK73GB1J223J	CHIP R 22K J 1/16W		R799			RK73GB1J102J	CHIP R 1.0K J 1/16W	
R715			RK73GB1J103J	CHIP R 10K J 1/16W		R802			RK73FB2A2R2J	CHIP R 2.2 J 1/10W	
R717,718			RK73GB1J473J	CHIP R 47K J 1/16W		R803			RK73GB1J473J	CHIP R 47K J 1/16W	
R719			RK73GB1J154J	CHIP R 150K J 1/16W		R804			RK73GB1J102J	CHIP R 1.0K J 1/16W	
R720			RK73GB1J473J	CHIP R 47K J 1/16W		R805			RK73GB1J473J	CHIP R 47K J 1/16W	
R721			RK73GB1J223J	CHIP R 22K J 1/16W		R806			RK73GB1J102J	CHIP R 1.0K J 1/16W	
R722			RK73GB1J334J	CHIP R 330K J 1/16W		R807			RK73GB1J473J	CHIP R 47K J 1/16W	
R723,724			R92-1252-05	CHIP R 0 OHM J 1/16W		R808			RK73GB1J102J	CHIP R 1.0K J 1/16W	
R726			RK73GB1J473J	CHIP R 47K J 1/16W		R809			RK73GB1J473J	CHIP R 47K J 1/16W	
R727			R92-1252-05	CHIP R 0 OHM J 1/16W		R810			RK73GB1J102J	CHIP R 1.0K J 1/16W	
R728,729			RK73GB1J223J	CHIP R 22K J 1/16W		R811			RK73GB1J473J	CHIP R 47K J 1/16W	
R730			RK73GB1J101J	CHIP R 100 J 1/16W		R812			RK73GB1J223J	CHIP R 22K J 1/16W	
R731			RK73GB1J472J	CHIP R 4.7K J 1/16W		R813,814			RK73GB1J473J	CHIP R 47K J 1/16W	
R732			RK73GB1J473J	CHIP R 47K J 1/16W		R815			RK73GB1J104J	CHIP R 100K J 1/16W	
R733			R92-1252-05	CHIP R 0 OHM J 1/16W		R817			RK73GB1J101J	CHIP R 100 J 1/16W	
R734			RK73GB1J473J	CHIP R 47K J 1/16W		R818			RK73GB1J102J	CHIP R 1.0K J 1/16W	
R735			RK73GB1J333J	CHIP R 33K J 1/16W		R819-822			RK73GB1J103J	CHIP R 10K J 1/16W	
R736,737			RK73GB1J473J	CHIP R 47K J 1/16W		R823			RK73GB1J474J	CHIP R 470K J 1/16W	
R738			RK73GB1J274J	CHIP R 270K J 1/16W		R824			RK73GB1J472J	CHIP R 4.7K J 1/16W	
R739			RK73GB1J103J	CHIP R 10K J 1/16W		R825,826			RK73GB1J824J	CHIP R 820K J 1/16W	
R740			RK73GB1J104J	CHIP R 100K J 1/16W		R827			RK73GB1J822J	CHIP R 8.2K J 1/16W	
R741			RK73GB1J154J	CHIP R 150K J 1/16W		R828			RK73GB1J273J	CHIP R 27K J 1/16W	
R742			R92-0670-05	CHIP R 0 OHM		R829			RK73GB1J224J	CHIP R 220K J 1/16W	
R743			RK73GB1J473J	CHIP R 47K J 1/16W		R830			RK73GB1J563J	CHIP R 56K J 1/16W	
R744			RK73GB1J393J	CHIP R 39K J 1/16W		R831			RK73GB1J154J	CHIP R 150K J 1/16W	
R745			RK73GB1J473J	CHIP R 47K J 1/16W		R832			RK73GB1J822J	CHIP R 8.2K J 1/16W	
R747			RK73GB1J103J	CHIP R 10K J 1/16W		R833			RK73GB1J223J	CHIP R 22K J 1/16W	
R749-752			R92-1252-05	CHIP R 0 OHM J 1/16W		R834			RK73GB1J332J	CHIP R 3.3K J 1/16W	
R753,754			RK73GB1J473J	CHIP R 47K J 1/16W		R836			RK73GB1J473J	CHIP R 47K J 1/16W	
R758			RK73GB1J103J	CHIP R 10K J 1/16W		R837			RK73GB1J332J	CHIP R 3.3K J 1/16W	
R760			RK73GB1J122J	CHIP R 1.2K J 1/16W		R839,840			RK73GB1J561J	CHIP R 560 J 1/16W	
R762			RK73GB1J472J	CHIP R 4.7K J 1/16W		R841,842			R92-0670-05	CHIP R 0 OHM	
R763			RK73GB1J103J	CHIP R 10K J 1/16W		R843			RK73GB1J274J	CHIP R 270K J 1/16W	
R764,765			RK73GB1J102J	CHIP R 1.0K J 1/16W		R844			RK73GB1J334J	CHIP R 330K J 1/16W	
R766			RK73GB1J122J	CHIP R 1.2K J 1/16W		K1			S76-0401-05	RELAY	
R767			RK73GB1J473J	CHIP R 47K J 1/16W		D1-4			DAN235K	DIODE	
R768			RK73GB1J122J	CHIP R 1.2K J 1/16W		D5			MA742	DIODE	
R771			RK73GB1J122J	CHIP R 1.2K J 1/16W		D7			1SS355	DIODE	
R772			RK73GB1J473J	CHIP R 47K J 1/16W		D8			DAN235K	DIODE	
R773			RK73GB1J102J	CHIP R 1.0K J 1/16W		D11			02DZ5.1(Y)	ZENER DIODE	
R774			RK73GB1J105J	CHIP R 1.0M J 1/16W		D12			02DZ18(X,Y)	ZENER DIODE	
R775			RK73GB1J473J	CHIP R 47K J 1/16W		D13			MA742	DIODE	
R776			RK73GB1J102J	CHIP R 1.0K J 1/16W		D600			DA204U	DIODE	
R777			RK73GB1J473J	CHIP R 47K J 1/16W		D606-612			DA204U	DIODE	
R778			RK73GB1J102J	CHIP R 1.0K J 1/16W		D614-616			DA204U	DIODE	
R779			RK73GB1J473J	CHIP R 47K J 1/16W		D618-623			DA204U	DIODE	
R780			RK73GB1J102J	CHIP R 1.0K J 1/16W		D626			MINISMDE190	VARISTOR	
R781			RK73GB1J471J	CHIP R 470 J 1/16W		D627,628			1SS355	DIODE	
R782			RK73GB1J473J	CHIP R 47K J 1/16W		D629			DA204U	DIODE	
R783			RK73GB1J102J	CHIP R 1.0K J 1/16W		IC1,2			NJM4558E	MOS-IC	
R785			RK73GB1J102J	CHIP R 1.0K J 1/16W							

PARTS LIST / 零件表

RX VCO UNIT (X58-480X-XX)

TX VCO UNIT (X58-481X-XX)

Ref. No.	Address	New parts	Parts No.	Description	Destination	Ref. No.	Address	New parts	Parts No.	Description	Destination
C369			CC73GCH1H070B	CHIP C 7.0PF B	C6	R368			RK73GB1J330J	CHIP R 33 J 1/16W	
C370,371			CC73GCH1H100C	CHIP C 10PF C		D350-353			1SV282	VARIABLE CAPACITANCE DIODE	
C372,373			CK73GB1H471K	CHIP C 470PF K		IC300			CD8468	MOS-IC	
C374,375			CC73GCH1H0R5B	CHIP C 0.5PF B		IC300			SA7025DK	MOS-IC	
C376-378			CK73GB1H471K	CHIP C 470PF K		Q300,301			2SC4116(GR)	TRANSISTOR	
						Q302			2SC4226(R24)	TRANSISTOR	
C379			CC73GCH1H040C	CHIP C 4.0PF C	C,C3	Q350,351			2SK508NV(K52)	FET	
C379			CC73GCH1H050C	CHIP C 5.0PF C	C6	Q352,353			2SC4116(Y)	TRANSISTOR	
C383			CK73GB1H471K	CHIP C 470PF K		Q354			DTC114EUA	DIGITAL TRANSISTOR	
C386			CC73GCH1H101J	CHIP C 100PF J		Q355			2SC4226(R24)	TRANSISTOR	
TC350,351			C05-0396-05	CERAMIC TRIMMER CAPACITOR (8PF)		TX VCO UNIT (X58-481X-XX) 0-10 : C 0-12 : C3 3-01 : C6					
CN300			E40-5699-05	PIN ASSY		C304,305			CK73GB1H102K	CHIP C 1000PF K	
CN350			E40-5755-05	PIN ASSY		C306			CK73GB1H103K	CHIP C 0.010UF K	
CN351			E40-6098-05	PIN ASSY		C307			CK73GB1H471K	CHIP C 470PF K	
-			F10-2377-04	SHIELDING CASE		C308-310			CK73FB1E104K	CHIP C 0.10UF K	
L300			L92-0148-05	CHIP FERRITE		C311			C92-0001-05	CHIP-TAN 0.1UF 35WV	
L301,302			L40-1875-34	SMALL FIXED INDUCTOR (18NH)	C,C3	C312			CC73GCH1H060D	CHIP C 6.0PF D	C
L301,302			L40-2275-34	SMALL FIXED INDUCTOR (22NH)	C6	C312			CC73GCH1H070D	CHIP C 7.0PF D	C3
L303			L40-2275-34	SMALL FIXED INDUCTOR (22NH)	C	C312			CC73GCH1H080D	CHIP C 8.0PF D	C6
L303			L40-2775-34	SMALL FIXED INDUCTOR (27NH)	C3	C314			CC73GCH1H120J	CHIP C 12PF J	C,C3
L303			L40-3371-34	SMALL FIXED INDUCTOR (33NH)	C6	C314			CC73GCH1H180J	CHIP C 18PF J	C6
L350-355			L40-1095-34	SMALL FIXED INDUCTOR (1UH)		C315			CK73FB1H473K	CHIP C 0.047UF K	
L356,357			L34-4608-05	AIR-CORE COIL	C	C317			CC73GCH1H060D	CHIP C 6.0PF D	C
L356,357			L34-4609-05	AIR-CORE COIL	C3,C6	C317			CC73GCH1H070D	CHIP C 7.0PF D	C3
L358-361			L40-1595-34	SMALL FIXED INDUCTOR (1.5UH)		C317			CC73GCH1H080D	CHIP C 8.0PF D	C6
L362			L40-3371-34	SMALL FIXED INDUCTOR (33NH)	C,C3	C318			C92-0514-05	CHIP-TAN 2.2UF 10WV	
L362			L40-3975-34	SMALL FIXED INDUCTOR (39NH)	C6	C319			CK73GB1H471K	CHIP C 470PF K	
R300			RK73GB1J100J	CHIP R 10 J 1/16W		C320			C92-0514-05	CHIP-TAN 2.2UF 10WV	
R301-304			RK73GB1J101J	CHIP R 100 J 1/16W		C321			CC73GCH1H040C	CHIP C 4.0PF C	C,C3
R305			R92-1252-05	CHIP R 0 OHM J 1/16W		C321			CC73GCH1H060D	CHIP C 6.0PF D	C6
R306			RK73GB1J220J	CHIP R 22 J 1/16W		C322			CK73GB1H471K	CHIP C 470PF K	
R308			RK73GB1J560J	CHIP R 56 J 1/16W		C323			CK73FB1E224K	CHIP C 0.22UF K	
R309			RK73GB1J221J	CHIP R 220 J 1/16W	C6	C324			C92-0002-05	CHIP-TAN 0.22UF 35WV	C
R309			RK73GB1J331J	CHIP R 330 J 1/16W	C,C3	C324			C92-0502-05	CHIP-TAN 0.33UF 35WV	C3,C6
R310			RK73GB1J332J	CHIP R 3.3K J 1/16W		C325			CC73GCH1H040C	CHIP C 4.0PF C	
R311			RK73GB1J103J	CHIP R 10K J 1/16W		C329,330			CK73GB1H471K	CHIP C 470PF K	
R312			RK73GB1J221J	CHIP R 220 J 1/16W	C6	C350,351			CK73GB1H471K	CHIP C 470PF K	C
R312			RK73GB1J331J	CHIP R 330 J 1/16W	C,C3	C351			CK73GB1H471K	CHIP C 470PF K	C3,C6
R313			RK73GB1J222J	CHIP R 2.2K J 1/16W		C352			CC73GCH1H101J	CHIP C 100PF J	
R314			RK73GB1J474J	CHIP R 470K J 1/16W		C353			CK73GB1H471K	CHIP C 470PF K	C3,C6
R315			RK73GB1J151J	CHIP R 150 J 1/16W		C354			CK73GB1H471K	CHIP C 470PF K	C
R316			RK73FB2A152J	CHIP R 1.5K J 1/10W		C355			CC73GCH1H100C	CHIP C 10PF C	C3
R317,318			R92-1252-05	CHIP R 0 OHM J 1/16W		C355			CC73GCH1H150G	CHIP C 15PF G	C6
R319			RK73GB1J330J	CHIP R 33 J 1/16W		C356			CC73GCH1H080B	CHIP C 8.0PF B	C
R320			RK73GB1J222J	CHIP R 2.2K J 1/16W		C357			CK73GB1H471K	CHIP C 470PF K	C3,C6
R321			RK73GB1J273J	CHIP R 27K J 1/16W		C358			CC73GCH1H030B	CHIP C 3.0PF B	C3
R322			RK73GB1J103J	CHIP R 10K J 1/16W		C358			CC73GCH1H1R5B	CHIP C 1.5PF B	C6
R350-353			R92-1252-05	CHIP R 0 OHM J 1/16W		C359			CC73GCH1H1R5B	CHIP C 1.5PF B	C
R354,355			RK73GB1J330J	CHIP R 33 J 1/16W		C360			CK73FB1E104K	CHIP C 0.10UF K	C
R356			RK73GB1J221J	CHIP R 220 J 1/16W	C,C3	C361			CK73FB1E104K	CHIP C 0.10UF K	C3,C6
R356,357			RK73GB1J271J	CHIP R 270 J 1/16W	C6	C362			CC73GCH1H120G	CHIP C 12PF G	C
R357			RK73GB1J181J	CHIP R 180 J 1/16W	C,C3	C363			CC73GCH1H120G	CHIP C 12PF G	C6
R358,359			RK73GB1J470J	CHIP R 47 J 1/16W		C363			CC73GCH1H180G	CHIP C 18PF G	C3
R360-363			RK73GB1J472J	CHIP R 4.7K J 1/16W		C364			CK73GB1H471K	CHIP C 470PF K	C
R364			RK73GB1J103J	CHIP R 10K J 1/16W		C365			CK73GB1H471K	CHIP C 470PF K	C3,C6
R365			RK73GB1J333J	CHIP R 33K J 1/16W		C366			CC73GCH1H070B	CHIP C 7.0PF B	C
R366			RK73GB1J103J	CHIP R 10K J 1/16W							
R367			RK73GB1J101J	CHIP R 100 J 1/16W	C,C3						
R367			RK73GB1J271J	CHIP R 270 J 1/16W	C6						

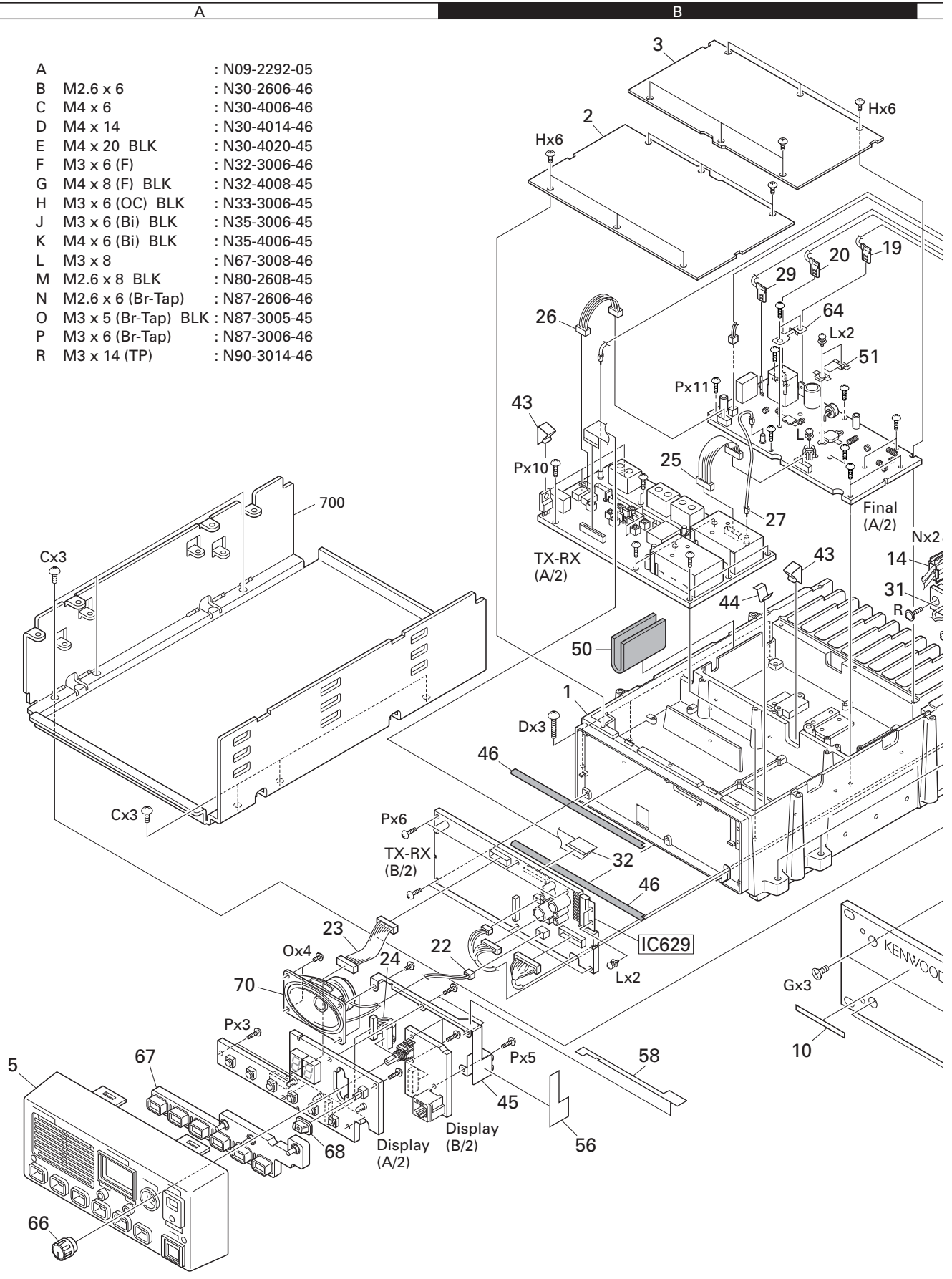
PARTS LIST / 零件表

TX VCO UNIT (X58-481X-XX)

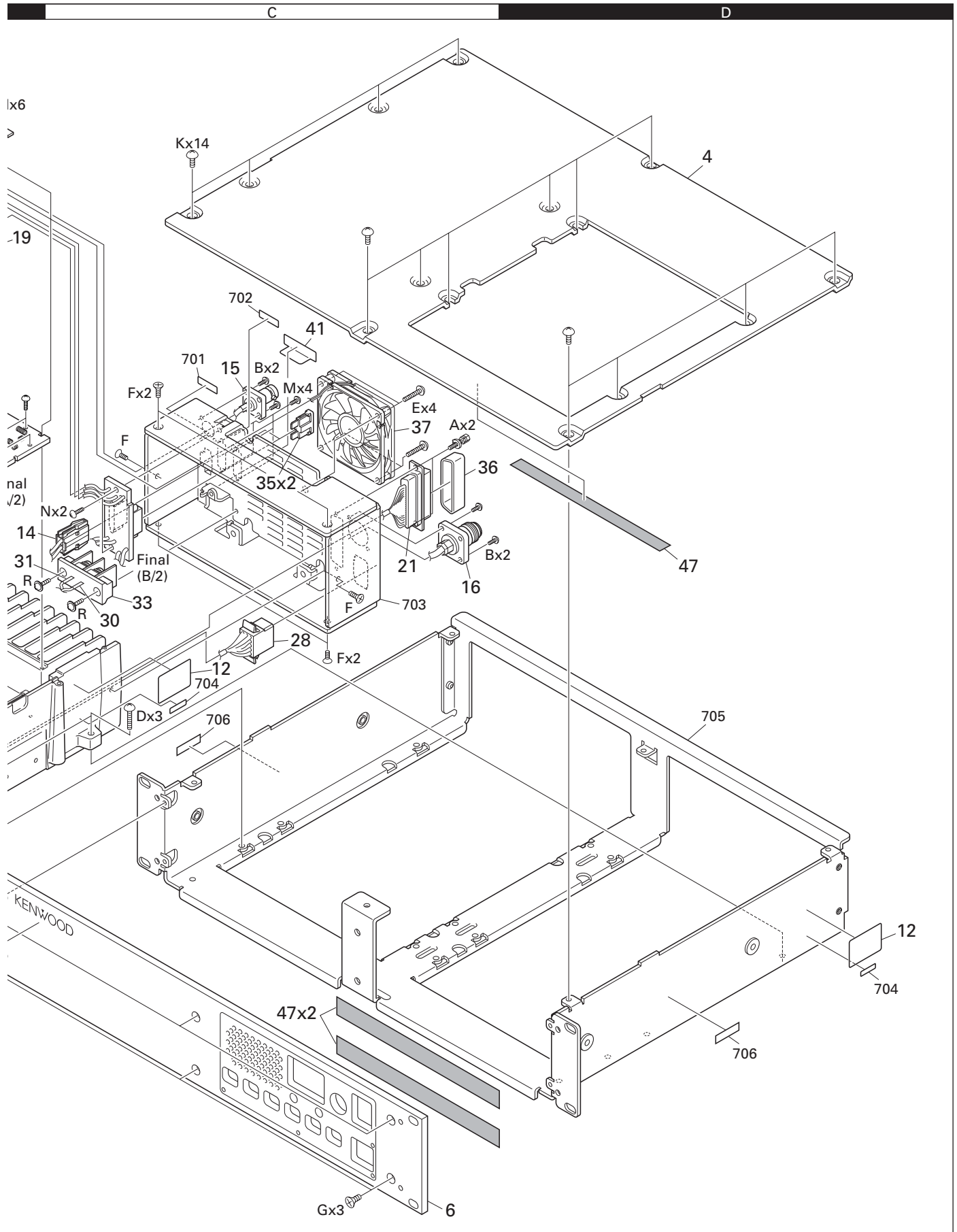
Ref. No.	Address	New parts	Parts No.	Description	Destination	Ref. No.	Address	New parts	Parts No.	Description	Destination
C367			CC73GCH1H070B	CHIP C 7.0PF B	C3	R322			RK73GB1J103J	CHIP R 10K J 1/16W	
C367			CC73GCH1H080B	CHIP C 8.0PF B	C6	R350			R92-1252-05	CHIP R 0 OHM J 1/16W	C3,C6
C368			CC73GCH1H070B	CHIP C 7.0PF B	C	R351			R92-1252-05	CHIP R 0 OHM J 1/16W	C
C369			CC73GCH1H080B	CHIP C 8.0PF B	C3	R352			R92-1252-05	CHIP R 0 OHM J 1/16W	C3,C6
C369			CC73GCH1H090B	CHIP C 9.0PF B	C6	R353			R92-1252-05	CHIP R 0 OHM J 1/16W	C
C370			CC73GCH1H070B	CHIP C 7.0PF B	C	R354			RK73GB1J330J	CHIP R 33 J 1/16W	C
C371			CC73GCH1H080B	CHIP C 8.0PF B	C3	R355			RK73GB1J330J	CHIP R 33 J 1/16W	C3,C6
C371			CC73GCH1H090B	CHIP C 9.0PF B	C6	R358			RK73GB1J470J	CHIP R 47 J 1/16W	C3,C6
C374			CC73GCH1H0R5B	CHIP C 0.5PF B	C	R359			RK73GB1J470J	CHIP R 47 J 1/16W	C
C375			CC73GCH1H0R5B	CHIP C 0.5PF B	C3,C6	R365			RK73GB1J333J	CHIP R 33K J 1/16W	
C377,378			CK73GB1H471K	CHIP C 470PF K		R366			RK73GB1J103J	CHIP R 10K J 1/16W	
C379			CC73GCH1H040C	CHIP C 4.0PF C	C,C3	R367			RK73GB1J820J	CHIP R 82 J 1/16W	
C379			CC73GCH1H050C	CHIP C 5.0PF C	C6	R368			RK73GB1J330J	CHIP R 33 J 1/16W	
C380			CC73GCH1H0R5B	CHIP C 0.5PF B	C	R372,373			RK73GB1J104J	CHIP R 100K J 1/16W	C
C381			CC73GCH1H0R5B	CHIP C 0.5PF B	C3,C6	R374,375			RK73GB1J104J	CHIP R 100K J 1/16W	C3,C6
C382,383			CC73GCH1H471J	CHIP C 470PF J		R376			RK73GB1J181J	CHIP R 180 J 1/16W	C
TC350			C05-0396-05	CERAMIC TRIMMER CAPACITOR (8PF)	C	R377			RK73GB1J181J	CHIP R 180 J 1/16W	C3,C6
TC351			C05-0396-05	CERAMIC TRIMMER CAPACITOR (8PF)	C3,C6						
CN300			E40-5699-05	PIN ASSY		D350			1SV282	VARIABLE CAPACITANCE DIODE	C
CN350			E40-5755-05	PIN ASSY		D351			1SV282	VARIABLE CAPACITANCE DIODE	C3,C6
CN351			E40-6098-05	PIN ASSY		D352			1SV282	VARIABLE CAPACITANCE DIODE	C
-			F10-2377-04	SHIELDING CASE		D353			1SV282	VARIABLE CAPACITANCE DIODE	C3,C6
-						D354			1SV214	VARIABLE CAPACITANCE DIODE	C
L300			L92-0148-05	CHIP FERRITE		D355			1SV214	VARIABLE CAPACITANCE DIODE	C3,C6
L301,302			L40-1575-34	SMALL FIXED INDUCTOR (15NH)	C	IC300			CD8468	MOS-IC	
L301,302			L40-1875-34	SMALL FIXED INDUCTOR (18NH)	C3,C6	IC300			SA7025DK	MOS-IC	
L303			L40-2275-34	SMALL FIXED INDUCTOR (22NH)	C	Q300,301			2SC4116(GR)	TRANSISTOR	
L303			L40-2775-34	SMALL FIXED INDUCTOR (27NH)	C3	Q302			2SC4226(R24)	TRANSISTOR	
L303			L40-3371-34	SMALL FIXED INDUCTOR (33NH)	C6	Q350			2SK508NV(K52)	FET	C
L304-307			L92-0140-05	CHIP FERRITE		Q351			2SK508NV(K52)	FET	C3,C6
L350,351			L40-1095-34	SMALL FIXED INDUCTOR (1UH)	C3,C6	Q355			2SC4226(R24)	TRANSISTOR	
L352-354			L40-1095-34	SMALL FIXED INDUCTOR (1UH)	C						
L355			L40-1095-34	SMALL FIXED INDUCTOR (1UH)	C3,C6						
L356			L34-4645-05	AIR-CORE COIL	C						
L357			L34-4607-05	AIR-CORE COIL	C3						
L357			L34-4608-05	AIR-CORE COIL	C6						
L358			L40-1095-34	SMALL FIXED INDUCTOR (1UH)	C						
L359			L40-1595-34	SMALL FIXED INDUCTOR (1.5UH)	C3,C6						
L360			L40-1095-34	SMALL FIXED INDUCTOR (1UH)	C						
L361			L40-1595-34	SMALL FIXED INDUCTOR (1.5UH)	C3,C6						
L362			L40-3371-34	SMALL FIXED INDUCTOR (33NH)	C,C3						
L362			L40-3975-34	SMALL FIXED INDUCTOR (39NH)	C6						
R300			RK73GB1J100J	CHIP R 10 J 1/16W							
R301-304			RK73GB1J101J	CHIP R 100 J 1/16W							
R305			R92-1252-05	CHIP R 0 OHM J 1/16W							
R306			RK73GB1J220J	CHIP R 22 J 1/16W							
R308			RK73GB1J560J	CHIP R 56 J 1/16W							
R309			RK73GB1J331J	CHIP R 330 J 1/16W							
R310			RK73GB1J332J	CHIP R 3.3K J 1/16W							
R311			RK73GB1J103J	CHIP R 10K J 1/16W							
R312			RK73GB1J331J	CHIP R 330 J 1/16W							
R313			RK73GB1J222J	CHIP R 2.2K J 1/16W							
R314			RK73GB1J474J	CHIP R 470K J 1/16W							
R315			RK73GB1J151J	CHIP R 150 J 1/16W							
R316			RK73FB2A152J	CHIP R 1.5K J 1/10W							
R317,318			R92-1252-05	CHIP R 0 OHM J 1/16W							
R319			RK73GB1J330J	CHIP R 33 J 1/16W							
R320			RK73GB1J222J	CHIP R 2.2K J 1/16W							
R321			RK73GB1J273J	CHIP R 27K J 1/16W							

EXPLODED VIEW / 部件分解图

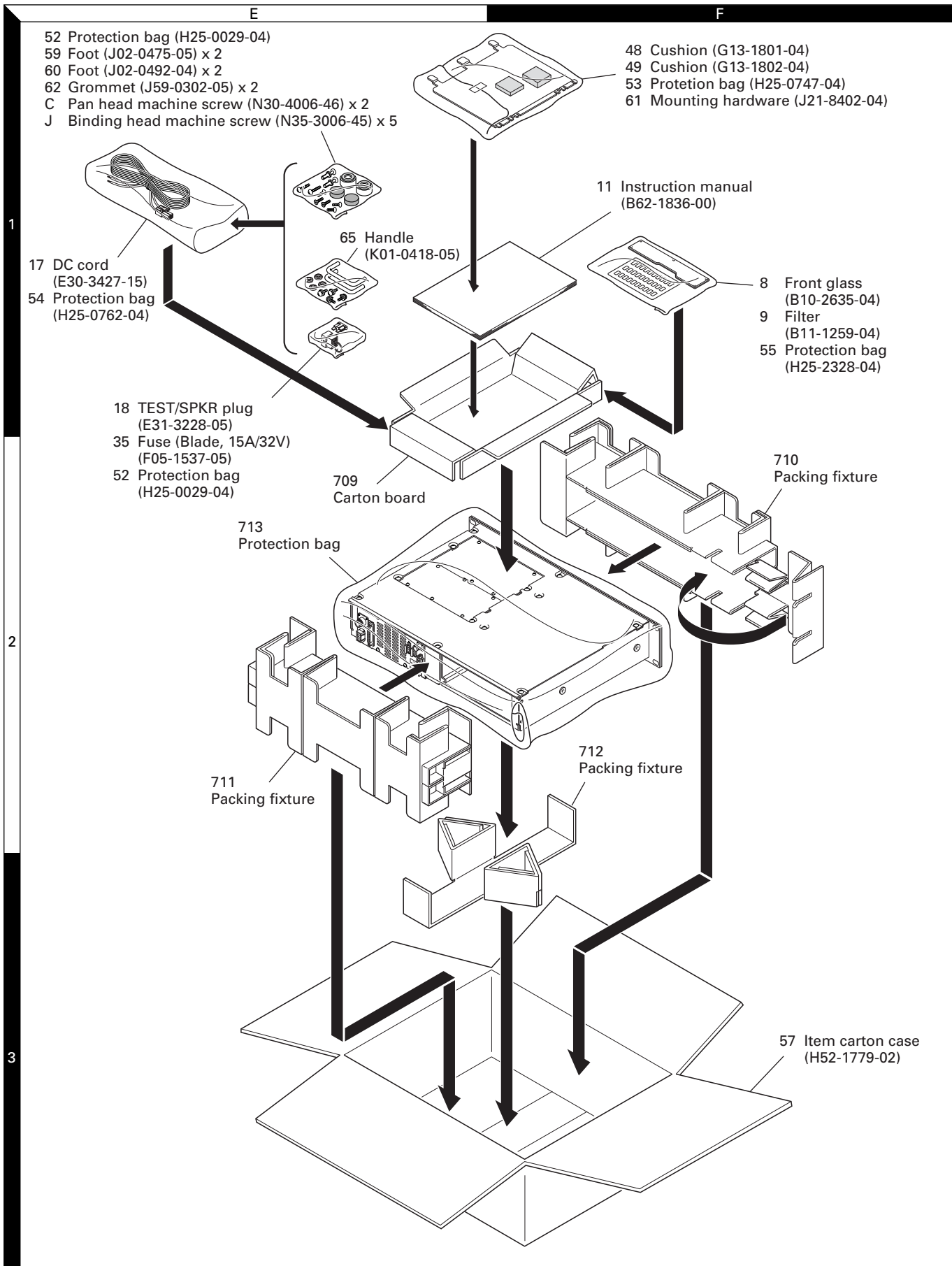
- | | | |
|---|---------------------|---------------|
| A | : | N09-2292-05 |
| B | M2.6 x 6 | : N30-2606-46 |
| C | M4 x 6 | : N30-4006-46 |
| D | M4 x 14 | : N30-4014-46 |
| E | M4 x 20 BLK | : N30-4020-45 |
| F | M3 x 6 (F) | : N32-3006-46 |
| G | M4 x 8 (F) BLK | : N32-4008-45 |
| H | M3 x 6 (OC) BLK | : N33-3006-45 |
| J | M3 x 6 (Bi) BLK | : N35-3006-45 |
| K | M4 x 6 (Bi) BLK | : N35-4006-45 |
| L | M3 x 8 | : N67-3008-46 |
| M | M2.6 x 8 BLK | : N80-2608-45 |
| N | M2.6 x 6 (Br-Tap) | : N87-2606-46 |
| O | M3 x 5 (Br-Tap) BLK | : N87-3005-45 |
| P | M3 x 6 (Br-Tap) | : N87-3006-46 |
| R | M3 x 14 (TP) | : N90-3014-46 |



EXPLODED VIEW / 部件分解图



PACKING / 包装

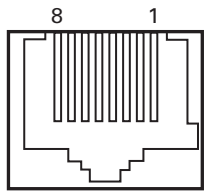


ADJUSTMENT

Test Equipment Required for Alignment

Test Equipment	Major Specifications	
1. Standard Signal Generator (SSG)	Frequency Range	300 to 512MHz
	Modulation	Frequency modulation and external modulation
	Output	0.1μV to greater than 1mV
2. Power Meter	Input Impedance	50Ω
	Operation Frequency	300 to 512MHz or more
	Measurement Capability	Vicinity of 100W
3. Deviation Meter	Frequency Range	300 to 512MHz
4. Digital Volt Meter (DVM)	Measuring Range	1 to 20V DC
	Accuracy	High input impedance for minimum circuit loading
5. Oscilloscope		DC through 30MHz
6. High Sensitivity Frequency Counter	Frequency Range	10Hz to 600MHz
	Frequency Stability	0.2ppm or less
7. Ammeter		15A or more
8. AF Volt Meter (AF VTVM)	Frequency Range	50Hz to 10kHz
	Voltage Range	3mV to 3V
9. Audio Generator (AG)	Frequency Range	50Hz to 5kHz
	Output	0 to 1V
10. Distortion Meter	Capability	3% or less at 1kHz
	Input Level	50mV to 10Vrms
11. Voltmeter	Measuring Range	10 to 1.5V DC or less
	Input Impedance	50kΩ/V or greater
12. 4Ω Dummy Load		Approx. 4Ω, 5W

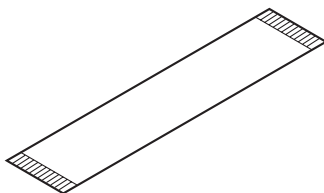
MIC connector (Front panel view)



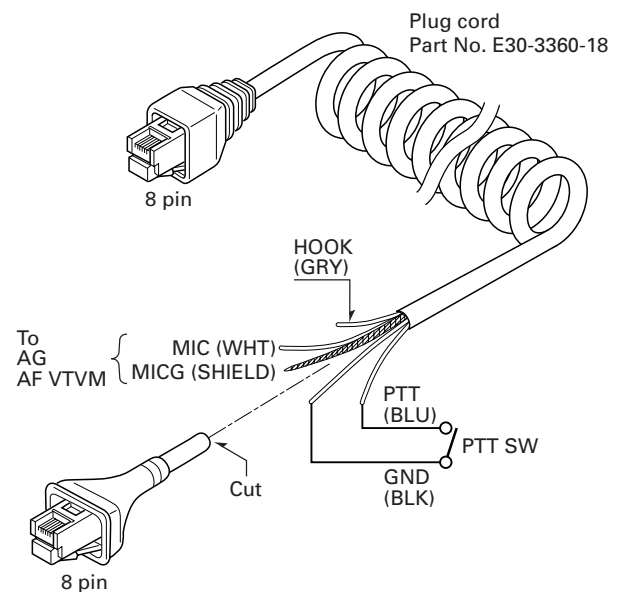
- 1 : NC
- 2 : +B
- 3 : GND
- 4 : PTT/TXD1 (PC serial data from radio)
- 5 : MIC GND
- 6 : MIC
- 7 : HOOK/RXD1 (PC serial data to radio)
- 8 : NC

Flat cable (36-pin) about 256mm

To connect the TX-RX unit A/2 (CN14) to the TX-RX unit B/2 (CN602) while in servicing, you can use the 36-pin flat cable, E37-0979-05, which is available from the KENWOOD parts center.



Test cable for microphone input

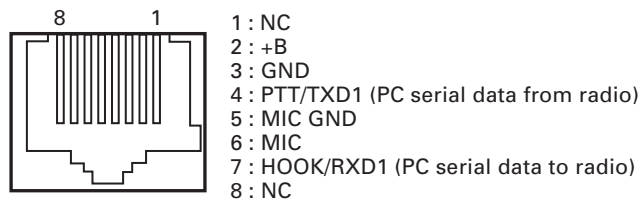


调整

所需的用于调整的测试设备

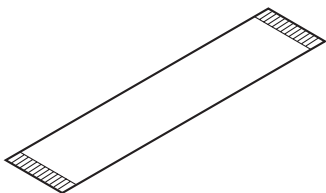
测试设备	主要特性	
1. 标准信号发生器 (SSG)	频率范围 调制 输出	300到512MHz 调频和外部调制 0.1 μ V到大于1mV
2. 功率计	输入阻抗 工作频率 测量范围	50 Ω 300到512MHz或更高 100W左右
3. 偏差仪	频率范围	300到512MHz
4. 数字电压表 (DVM)	测量范围 输入阻抗	直流1V到20V 最小电路负载时为高输入阻抗
5. 示波器		直流到30MHz
6. 高灵敏度频率计数器	频率范围 频率稳定性	10Hz到600MHz 0.2ppm或更低
7. 电流表		15A
8. 音频电压表 (AF VTVM)	频率范围 电压范围	50Hz到10kHz 3mV到3V
9. 音频发生器 (AG)	频率范围 输出	50Hz到5kHz 0到1V
10. 失真测试仪	测量能力 输入电平	在1kHz时3%或更低 50mV到10Vrms
11. 电压表	测量范围 输入阻抗	直流10V到1.5V或更低 50k Ω /V或更高
12. 4 Ω 假负载		大约4 Ω , 5W

麦克风连接器 (前面板视图)

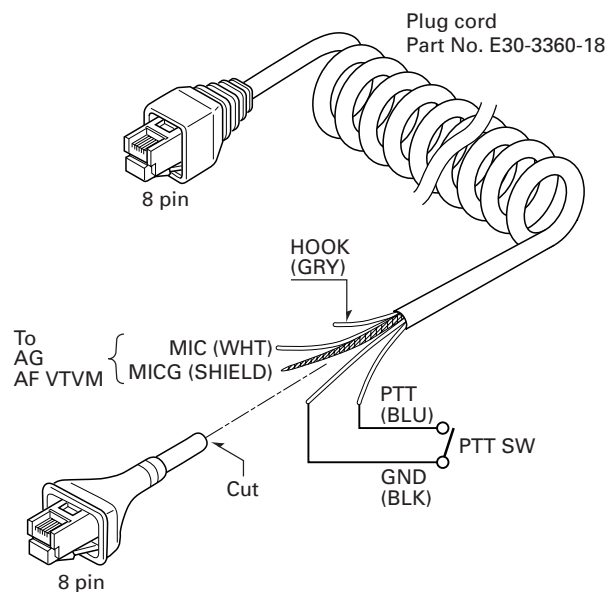


扁平电缆 (36芯)

控制部分与TX-RX部分连接用电缆(E37-0979-05)
长度256mm



用于麦克风输入的测试电缆



ADJUSTMENT / 调整

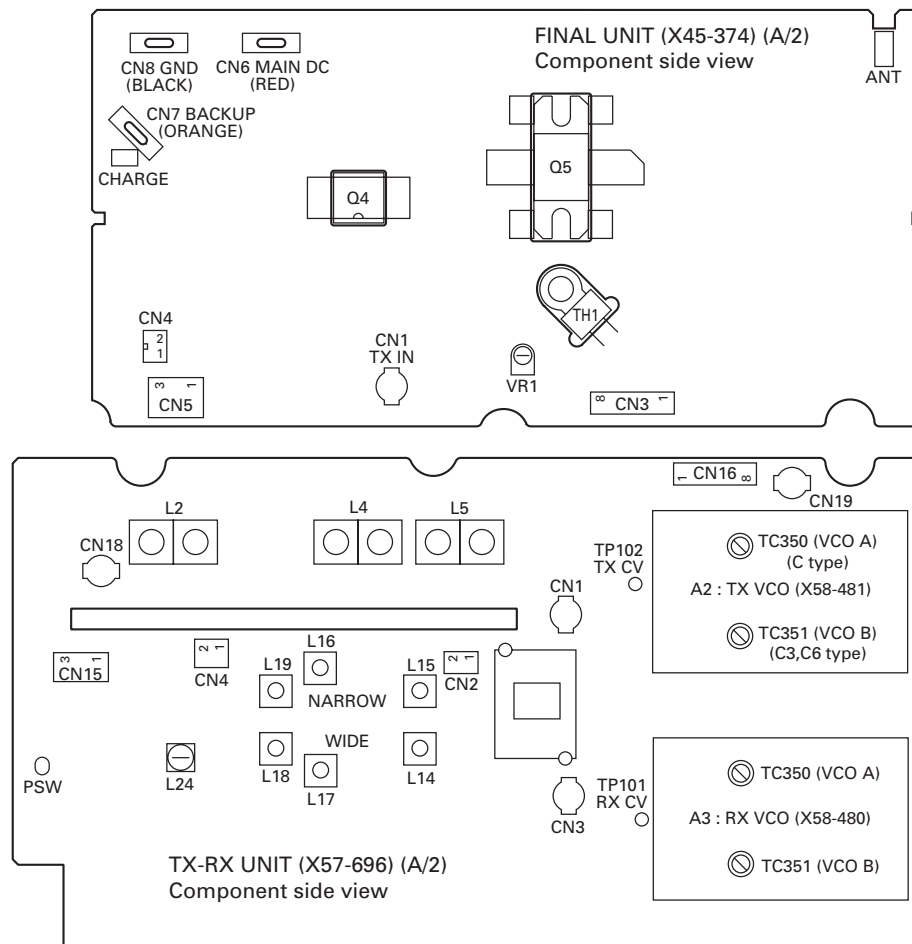
Test Channel (Default) / 测试频率 (出厂设定)

No. 号码	C		C3		C6	
	RX / 接收	TX / 发射	RX / 接收	TX / 发射	RX / 接收	TX / 发射
1	450.10	450.00	400.10	400.00	350.10	350.00
2	465.10	465.00	415.10	415.00	370.10	370.00
3	479.90	480.00	429.90	430.00	389.90	390.00
4	455.10	455.00	405.10	405.00	365.10	365.00
5	460.10	460.00	410.10	410.00	375.10	375.00
6	470.10	470.00	420.10	420.00	380.10	380.00
7	475.10	475.00	425.10	425.00	385.10	385.00
8	462.60	462.50	412.60	412.50	368.60	368.00
9	467.60	467.50	417.60	417.50	372.60	372.00
10	440.10	440.00	419.90	420.00	360.10	360.00
11	459.90	460.00	439.90	440.00	369.90	370.00

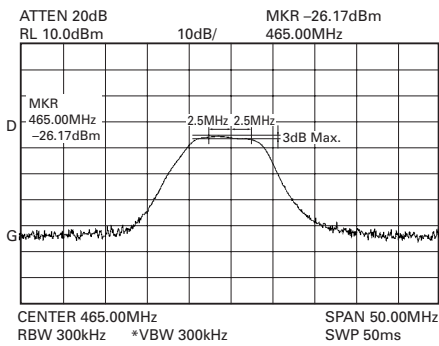
Test Signaling / 测试信令

No.	Decode / 解码	Encode / 编码
1	None	None
2	None	100Hz square wave
3	QT 67.0Hz	QT 67.0Hz
4	QT 151.4Hz	QT 151.4Hz
5	QT 210.7Hz	QT 210.7Hz
6	QT 250.3Hz	QT 250.3Hz
7	DQT 023N	DQT D023N
8	DQT 754I	DQT D754I
9	None	CW ID Encode [ID=VVV]
10	None	Single Tone [1000Hz]
11	DTMF 159D	DTMF 159D
12	None	DTMF Tone 9
13	None	Courtesy Tone
14	None	Battery Warning Tone
15	None	Battery Operation Tone
16	5-Tone [12345] (CCIR)	5-Tone [12345] (CCIR)

Adjustment Points / 调整点

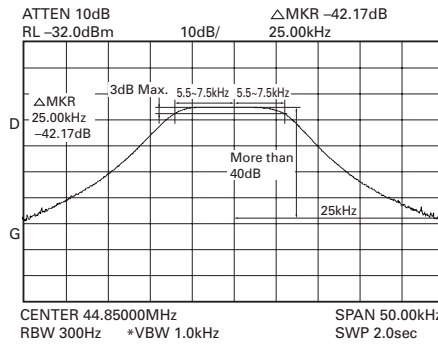


ADJUSTMENT



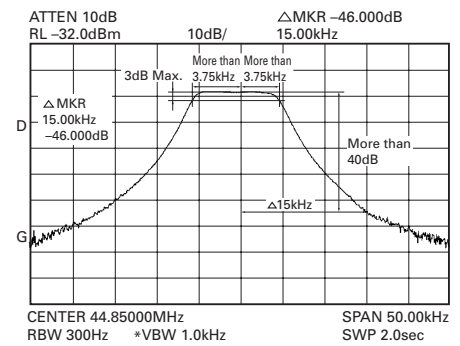
BPF center frequency (Factory-default)
C : 465MHz, C3 : 415MHz, C6 : 370MHz

Fig. 1



MCF : Wide

Fig. 2



MCF : Narrow

Fig. 3

Fine-Tuning the TKR-850

“ADJUSTMENT” items described in the Service Manual for the TKR-850 give the factory-default adjustment procedure covering all adjustment items.

However, it is not necessary to adjust all the items when adjusting the power, deviation, receiver sensitivity, etc at the frequency of the channel to be used by the TKR-850.

Adjustment procedure at the frequency of the channel to be used

1. Program a channel frequency using the FPU (KPG-91D(C)).
2. From the FPU menu, select in the order of “EDIT”, “Test Frequency” and “CH paste” to rewrite the test frequency from the factory-default to the one to be used for the channel.

Erase all channel frequencies rewritten through this operation and press the ENTER key to retrieve the factory-default test frequency.

Refer to the explanation given under HELP for the FPU (KPG-91D(C)) for details.

3. Check whether the frequency rewritten under the “Test mode” of the FPU (KPG-91D(C)) is correct, then select the item to be adjusted from the FPU (KPG-91D(C)) menu and adjust the set value for the item to an optimum value with the “TEST” tag.

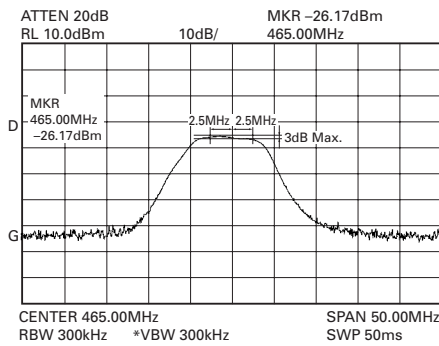
Note :

After adjustment of the “Max. Deviation”, be sure to check the “DQT balance”.

Alignment

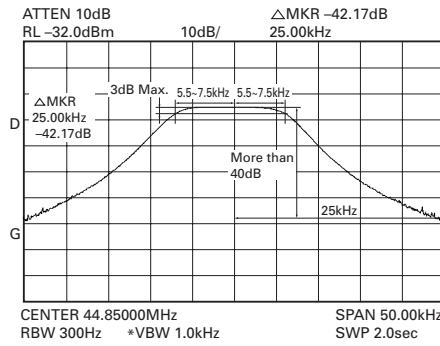
Item	Condition	Measurement			Adjustment			Specifications/Remarks
		Test-equipment	Unit	Terminal	Unit	Parts	Method	
1. Setting	1) Connect the unit to a suitable DC power supply.							
2. Write test frequency	1) Turn the DC source switch on after connecting a PC and FPU cable to the radio. 2) Write the test and shipping frequency to the radio. 3) End of test frequency writing.							→ “E1” appears on LED display → Green (BUSY) LED lights up
3. Setting	1) Connect the unit to a suitable DC power supply. 2) Turn the power switch on after connecting a PC and FPU cable to the radio. 3) Start up the program for the adjustment.							

调 整



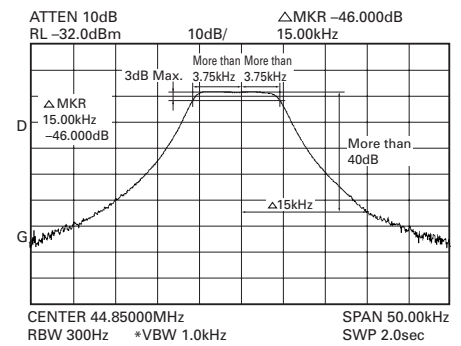
BPF中央频率 (出厂默认)
C : 465MHz, C3 : 415MHz, C6 : 370MHz

图1



MCF : 宽

图2



MCF : 窄

图3

TKR-850的微调

TKR-850维修手册中所描述的“ADJUSTMENT” (调整) 项目列出了涵盖所有调整项目的出厂默认调整步骤。然而, 当以TKR-850要使用的信道频率调节功率, 频偏, 接收机灵敏度等时, 没有必要调节所有的项目。

以要使用的信道频率进行调整的步骤

1. 使用FPU (KPG-91D(C)) 编程设定信道频率。
2. 从FPU菜单中, 按顺序依次选择EDIT (编辑), “Test Frequency” (测试频率) 和“CH paste” (信道粘贴) 把信道的出厂默认测试频率重写为一个将要使用的测试频率。

擦除所有通过这种操作重新写入的信道频率, 按ENTER键来恢复出厂默认测试频率。

细节请参考FPU (KPG-91D(C)) 的HELP菜单给出的解释。

3. 检查在FPU (KPG-91D(C)) 的“Test mode” (测试模式) 下重新写入的频率是否正确, 接着从FPU (KPG-91D(C)) 菜单中选择要调整的项目, 将该项目的设定值调整为一个具有“TEST” (测试) 标记的最优值。

注意 :

当完成对“Max. Deviation” (最大频偏) 的调整之后, 一定要对“DQT balance” (DQT平衡) 进行检查。

调整

项 目	条 件	测 量			调 整			规 格 / 备 注
		测量装置	单元	端子	单元	部件	方 法	
1. 设定	1) 将单元与对应的DC电源连接。							
2. 写入试验和出厂频率	1) 将电脑和FPU电缆与电台连接后接通电源开关。 2) 将试验和出厂频率写入电台。 3) 固件写入结束。							→ LED显示屏出现“E1”。 → 绿色 (BUSY) LED点亮。
3. 设定	1) 将单元与对应的DC电源连接。 2) 将电脑和FPU电缆与电台连接后接通电源开关。 3) 启动调整程序。							

ADJUSTMENT

Item	Condition	Measurement			Adjustment			Specifications/Remarks
		Test-equipment	Unit	Terminal	Unit	Parts	Method	
4. RX PLL lock voltage	1) RX VCO A high CH : 11 C,C6 CH : 10 C3	DVM	TX-RX (A/2)	RX-CV	RX VCO (A3)	TC350	1.50V	±0.1V
	2) RX VCO A low CH : 10 C CH : 1 C3,C6						Check	8V or less
	3) RX VCO B high CH : 3 C,C6 CH : 11 C3				RX VCO (A3)	TC351	1.50V	±0.1V
	4) RX VCO B low CH : 5 C CH : 6 C3 CH : 2 C6						Check	8V or less
5. TX PLL lock voltage	1) TX VCO high CH : 3			TX-CV	TX VCO (A2)	TC350 C TC351 C3,C6	1.50V	±0.1V
	2) TX VCO low CH : 1					Check	8V or less	
6. RX frequency	1) Connect the frequency counter to CN3, then measure the frequency CH : 2	f. counter		CN3			PC adj. Test CH-44.85MHz	50Hz or less
Note : RX frequency means the local frequency of the RX VCO. So its frequency is wanted frequency minus the IF frequency.								
7. Setting	1) Remove 8 pin cable and the coaxial cable from CN16, and CN19 on TX-RX side.							
8. TX frequency	1) Connect the frequency counter to CN19, then measure the frequency CH : 2	f. counter	TX-RX (A/2)	CN19			PC adj.	50Hz or less
9. Setting	1) Insert 8 pin cable and the coaxial cable to CN16, and CN19 on TX-RX side.							
10. Maximum power limiting	1) Measure the RF power at TX ANT. High CH	Power meter	Rear	TX ANT	Final	VR1	Adjust the RF power to 43W.	±1W
11. TX RF high power	1) Measure the RF power at TX ANT. Low CH 2) Center CH 3) High CH						PC adj. 40W (Factory-default)	±1W
12. TX RF low power	1) Measure the power level at TX ANT. Low CH 2) Center CH 3) High CH						PC adj. 25W (Factory-default)	±1W
13. BPF	1) Connect the TG to RX ANT, then connect CN1 to the spectrum analyzer input. Spectrum analyzer setting Span : 50MHz Scale : 10dB to 5dB div Tracking generator setting Output : -30dBm	Tracking generator	Rear	RX ANT	TX-RX (A/2)	L2 L4 L5	Center the frequency you are using, then adjust it to look like the wave Fig. 1. (Page 52)	
		Spectrum analyzer	TX-RX (A/2)	CN1				

调 整

项 目	条 件	测 量			调 整			规 格 / 备 注
		测量装置	单元	端子	单元	部件	方 法	
4. RX PLL 锁定 电压调整	1) RX VCO A高 CH : 11 C, C6 CH : 10 C3	DVM	TX-RX (A/2)	RX-CV	RX VCO (A3)	TC350	1.50V	± 0.1V
	2) RX VCO A低 CH : 10 C CH : 1 C3, C6						检查	8V或更低
	3) RX VCO B高 CH : 3 C, C6 CH : 11 C3				RX VCO (A3)	TC351	1.50V	± 0.1V
	4) RX VCO B低 CH : 5 C CH : 6 C3 CH : 2 C6						检查	8V或更低
5. TX PLL 锁定 电压调整	1) TX VCO高 CH : 3			TX-CV	TX VCO (A2)	TC350 C TC351 C3, C6	1.50V	± 0.1V
	2) TX VCO低 CH : 1						检查	8V或更低
6. RX 频率调整	1) 将频率计与CN3连接, 然后测定频率。 CH : 2	频率计		CN3			PC调整 试验CH - 44.85MHz	50Hz或更低
注意： 频率表示RX VCO的本机频率。因此该频率为所需频率 - 中频频率。								
7. 设定	1) 从：TX-RX侧的CN16和CN19取下8插脚电缆和同轴电缆。							
8. TX 频率调整	1) 将频率计与CN19连接, 然后测量频率。 CH : 2	频率计	TX-RX (A/2)	CN19			PC调整	50Hz或更低
9. 设定	1) 向：TX-RX侧的CN16和CN19插入8插脚电缆和同轴电缆。							
10. 最大功率 限制	1) 在TX天线测试射频功率。 高CH	功率计	后侧	TX天线	Final	VR1	将射频功率调整到 43W	± 1W
11. TX射频 高功率调整	1) 在TX天线测试射频功率。 低CH 2) 中央CH 3) 高CH						PC调整 40W (出厂默认)	± 1W
12. TX射频 低功率调整	1) 在TX天线测试射频功率。 低CH 2) 中央CH 3) 高CH						PC调整 25W (出厂默认)	± 1W
13. BPF调整	1) 将TG与RX天线连接,然后将 CN1与频谱分析仪的输入连接。 频谱分析仪 量程：50MHz 刻度：10dB至5dB 跟踪发生器 输出：- 30dBm	频谱分析仪 跟踪发生器	后侧 TX-RX (A/2)	RX天线 CN1	TX-RX (A/2)	L2 L4 L5	将使用的频率置于 中央,然后将波形 调整成为图1的形状。 (请参照第53页)	

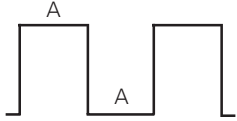
ADJUSTMENT

Item	Condition	Measurement			Adjustment			Specifications/Remarks
		Test-equipment	Unit	Terminal	Unit	Parts	Method	
14. MCF (Wide)	1) Connect the TG to CN2, then connect CN4 to the spectrum analyzer input. CH : 2 (Wide) Spectrum analyzer setting Span : 50kHz to 25kHz Scale : 10dB to 2dB div Center freq' : 44.850MHz Tracking generator setting Output : -30dBm	Tracking generator	Rear	RX ANT	TX-RX (A/2)	L14 L17 L18	Adjust it to look like the wave Fig. 2. (Page 52)	
(Narrow)	2) CH : 2 (Narrow)	Spectrum analyzer	TX-RX (A/2)	CN2 CN4		L15 L16 L19	Adjust it to look like the wave Fig. 3. (Page 52)	
15. Discriminator	1) Connect the SSG to RX ANT. CH : 2 (Wide) SSG output : -53dBm/501 μ V SSG MOD : 1kHz SSG DEV : 3kHz AF : 2V/4 Ω	SSG AF VM Distortion meter	Rear	RX ANT TEST/SPKR jack SPO (pin 12)		L24	Adjust the distortion to minimum.	
16. Threshold squelch (Wide)	1) Connect SSG to RX ANT. CH : 2 (Wide) SSG output : 4dB below to 12dB SINAD level SSG MOD : 1kHz SSG DEV : 3kHz AF : 2V/4 Ω	SSG Audio analyzer VTVM Oscilloscope	Rear	RX ANT TEST/SPKR jack SPO (pin 12)			PC adj. Adjust to point of closing squelch	
	2) SSG : OFF						Check	Squelch must be closed.
(Narrow)	3) CH : 2 (Narrow) SSG output : 4dB below to 12dB SINAD level SSG MOD : 1kHz SSG DEV : 1.5kHz AF : 2V/4 Ω						PC adj. Adjust to point of closing squelch	
	4) SSG : OFF						Check	Squelch must be closed.
17. Tight squelch (Wide)	1) Connect SSG to RX ANT. CH : 2 (Wide) SSG output : 7dB over to 12dB SINAD level SSG MOD : 1kHz SSG DEV : 3kHz AF : 2V/4 Ω						PC adj. Adjust to point of opening squelch	
(Narrow)	2) CH : 2 (Narrow) SSG output : 7dB over to 12dB SINAD level SSG MOD : 1kHz SSG DEV : 1.5kHz AF : 2V/4 Ω						PC adj. Adjust to point of opening squelch	

调 整

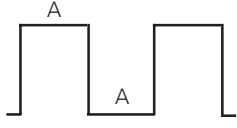
项 目	条 件	测 量			调 整			规 格 / 备 注
		测量装置	单元	端子	单元	部件	方 法	
14. MCF调整 (宽)	1) 将TG与CN2连接,然后将CN4与频谱分析仪的输入连接。 CH: 2 (宽) 频谱分析仪 量程: 50kHz至25kHz 刻度: 10dB至2dB 中央频率: 44.850MHz 跟踪发生器 输出: -30dBm	频谱分析仪 跟踪发生器	后侧 TX-RX (A/2)	RX天线 CN2 CN4	TX-RX (A/2)	L14 L17 L18	将波形调整成为图2的形状。 (请参照第53页)	
(窄)	2) CH: 2 (窄)					L15 L16 L19	将波形调整成为图3的形状。 (请参照第53页)	
15. 判别器调整	1) 将SSG与RX天线连接。 CH: 2 (宽) SSG输出: -53dBm/501 μ V SSG MOD: 1kHz SSG DEV: 3kHz AF: 2V/4欧姆	SSG AF VM 失真计	后侧	RX天线 试验/ 扬声器 SPO端子 (插脚12)		L24	将失真调整成为最小。	
16. 静噪阈值调整 (宽)	1) 将SSG与RX天线连接。 CH: 2 (宽) SSG输出: 3dB以下至12dB SINAD电平 SSG MOD: 1kHz SSG DEV: 3kHz AF: 2V/4欧姆	SSG 音频分析仪 VTVM 示波器	后侧	RX天线 试验/ 扬声器 SPO端子 (插脚12)			PC调整 调整至开启静噪点	
	2) SSG: 切断						检查	静噪必须关闭
(窄)	1) CH: 2 (窄) SSG输出: 3dB以下至12dB SINAD电平 SSG MOD: 1kHz SSG DEV: 1.5kHz AF: 2V/4欧姆						PC调整 调整至开启静噪点	
	2) SSG: 切断						检查	静噪必须关闭
17. 静噪精确调整 (宽)	1) 将SSG与RX天线连接。 CH: 2 (宽) SSG输出: 7dB以上至12dB SINAD电平 SSG MOD: 1kHz SSG DEV: 3kHz AF: 2V/4欧姆						PC调整 调整至开启静噪点	
(窄)	1) CH: 2 (窄) SSG输出: 7dB以下至12dB SINAD电平 SSG MOD: 1kHz SSG DEV: 1.5kHz AF: 2V/4欧姆						PC调整 调整至开启静噪点	

ADJUSTMENT

Item	Condition	Measurement			Adjustment			Specifications/Remarks
		Test-equipment	Unit	Terminal	Unit	Parts	Method	
18. RD out level (Wide)	1) Connect SSG to RX ANT. CH : 2 (Wide) SSG output : -53dBm/501μV SSG MOD : 1kHz SSG DEV : 3.0kHz	SSG	Rear	RX ANT			PC adj. 80mV	±5mV
(Narrow)	2) CH : 2 (Narrow) SSG output : -53dBm/501μV SSG MOD : 1kHz SSG DEV : 1.5kHz	DVM		CONTROL I/O jack RD (pin 10) 4.7kΩ load				
19. RA out level (Wide)	1) Connect SSG to RX ANT. CH : 2 (Wide) SSG output : -53dBm/501μV SSG MOD : 1kHz SSG DEV : 3.0kHz	SSG	Rear	RX ANT			PC adj. 400mV	±20mV
(Narrow)	2) CH : 2 (Narrow) SSG output : -53dBm/501μV SSG MOD : 1kHz SSG DEV : 1.5kHz	DVM		CONTROL I/O jack RA (pin 11) 4.7kΩ load				
20. Maximum deviation (Wide)	1) Connect AG to the MIC terminal. Low CH (TX VCO low) Center CH (VCO center) High CH (TX VCO high) Deviation meter filter HPF : OFF LPF : 15kHz De-emphasis : OFF AG : 1kHz/50mV (Terminal load) Transmission	MOD ANA or Deviation meter Oscilloscope	Rear	TX OUT			PC adj. 4.1kHz	±0.1kHz
(Narrow)	2) Low CH (TX VCO low) Center CH (VCO center) High CH (TX VCO high) Transmission	AG AF VTVM	Front	MIC			PC adj. 2.05kHz	
21. DQT balance (Wide)	1) CH : 2 Deviation meter filter HPF : OFF LPF : 3kHz De-emphasis : OFF Transmission	MOD ANA or Deviation meter Oscilloscope	Rear	TX OUT			PC adj. Make the de-modulated waves into square waves.	Oscilloscope DC range flat "A" part 
(Narrow)	2) CH : 2 Transmission							
22. QT deviation (Wide)	1) CH : 2 Deviation meter filter HPF : OFF LPF : 3kHz De-emphasis : OFF Detector : p-p/2 Transmission			TX ANT			PC adj. 0.75kHz	±0.05kHz
(Narrow)	2) CH : 2 Transmission						PC adj. 0.35kHz	

Note : After adjustment of the "Max. Deviation", be sure to check the "DQT balance".

调 整

项 目	条 件	测 量			调 整			规 格 / 备 注
		测量装置	单元	端子	单元	部件	方 法	
18. RD输出 电平调整 (宽)	1) 将SSG与RX天线连接。 CH : 2 (宽) SSG输出 : - 53dBm/501 μ V SSG MOD : 1kHz SSG DEV : 3kHz	SSG DVM	后侧	RX天线 控制输入 /输出 RD端子 (插脚10) 4.7k Ω 负载			PC调整 80mV	\pm 5mV
(窄)	2) CH : 2 (窄) SSG输出 : - 53dBm/501 μ V SSG MOD : 1kHz SSG DEV : 1.5kHz							
19. RA输出 电平调整 (宽)	1) 将SSG与RX天线连接。 CH : 2 (宽) SSG输出 : - 53dBm/501 μ V SSG MOD : 1kHz SSG DEV : 3kHz	SSG DVM	后侧	RX天线 控制输入 /输出 RA端子 (插脚11) 4.7k Ω 负载			PC调整 400mV	\pm 20mV
(窄)	2) CH : 2 (窄) SSG输出 : - 53dBm/501 μ V SSG MOD : 1kHz SSG DEV : 1.5kHz							
20. 最大频偏 调整 (宽)	1) 将AG连接麦克风端子。 低CH (TX VCO低) 中央CH (VCO中央) 高CH (TX VCO高) 偏差计滤波器 HPF : 关闭 LPF : 15kHz 去加重 : 关闭 AG : 1kHz/50mV (终端负载) 发射	MOD ANA 或偏差仪 示波器 AG AF VTVM	后侧 面板	TX OUT MIC			PC调整 4.1kHz	\pm 0.1kHz
(窄)	2) 低CH (TX VCO低) 中央CH (VCO中央) 高CH (TX VCO高) 发射						PC调整 2.05kHz	\pm 0.1kHz
注意 : 当完成对最大频偏的调整之后, 一定要对DQT平衡进行检查。								
21. DQT 平衡调整 (宽)	1) CH : 2 偏差计滤波器 HPF : 关闭 LPF : 3kHz 去加重 : 关闭 发射	MOD ANA 或偏差仪 示波器	后侧	TX OUT			PC调整 使得解调波形为 方波	示波器DC范围 平坦的“A”部分。 
(窄)	2) CH : 2 发射							
22. QT 频偏调整 (宽)	1) CH : 2 偏差计滤波器 HPF : 关闭 LPF : 3kHz 去加重 : 关闭 检波器 : p-p/2 发射			TX天线			PC调整 0.75kHz	\pm 0.05kHz
(窄)	2) CH : 2 发射						PC调整 0.35kHz	\pm 0.05kHz

ADJUSTMENT

Item	Condition	Measurement			Adjustment			Specifications/Remarks
		Test-equipment	Unit	Terminal	Unit	Parts	Method	
23. DQT deviation (Wide)	1) CH : 2 Deviation meter filter HPF : OFF LPF : 3kHz De-emphasis : OFF Detector : Peak hold Transmission	MOD ANA or Deviation meter Oscilloscope	Rear	TX ANT			PC adj. 0.75kHz	±0.05kHz
	(Narrow)							
24. CW ID deviation (Wide)	1) CH2 Deviation meter filter HPF : OFF LPF : 15kHz De-emphasis : OFF Transmission						PC adj. 2kHz	±0.1kHz
	(Narrow)							
25. Test tone deviation (Wide)	1) CH : 2 Deviation meter filter HPF : OFF LPF : 15kHz De-emphasis : OFF Transmission						PC adj. 3kHz	±0.1kHz
	(Narrow)							
26. TA (TX audio input) deviation (Wide)	1) Insert AG output into the control I/O TA terminal (pin 9). CH : 2 Deviation meter filter HPF : OFF LPF : 15kHz De-emphasis : OFF AG freq' : 1kHz (Sine wave) AG level : 280mV Transmission	MOD ANA or Deviation meter Oscilloscope AG AF VTVM	Rear	TX ANT CONTROL I/O jack TA (pin 9)			PC adj. 3.0kHz	±0.1kHz
	(Narrow)							
27. TD deviation (Wide)	1) Insert AG output into the control I/O TD terminal (pin 8). CH : 2 Deviation meter filter HPF : OFF LPF : 3kHz De-emphasis : OFF AG freq' : 100Hz (Sine wave) AG level : 0.5Vp-p (177mVrms) Transmission			CONTROL I/O jack TD (pin 8)			PC adj. 0.75kHz	±0.1kHz
	(Narrow)							

调 整

项 目	条 件	测 量			调 整			规 格 / 备 注
		测量装置	单元	端子	单元	部件	方 法	
23. DQT 频偏调整 (宽)	1) CH : 2 偏差仪滤波器 HPF : 关闭 LPF : 3kHz 去加重 : 关闭 检波器 : 峰值保持 发射	MOD ANA 或偏差仪 示波器	后侧	TX天线			PC调整 0.75kHz	$\pm 0.05\text{kHz}$
(窄)	2) CH : 2 发射						PC调整 0.35kHz	$\pm 0.05\text{kHz}$
24. CW ID 频偏调整 (宽)	1) CH : 2 偏差仪滤波器 HPF : 关闭 LPF : 15kHz 去加重 : 关闭 发射						PC调整 2kHz	$\pm 0.1\text{kHz}$
(窄)	2) CH : 2 发射						PC调整 1kHz	$\pm 0.05\text{kHz}$
25. 试验音 频偏调整 (宽)	1) CH : 2 偏差仪滤波器 HPF : 关闭 LPF : 15kHz 去加重 : 关闭 发射						PC调整 3kHz	$\pm 0.1\text{kHz}$
(窄)	2) CH : 2 发射						PC调整 1.5kHz	$\pm 0.05\text{kHz}$
26. TA (TX音输入) 频偏调整 (宽)	1) 将AG输出插入控制输入/输出TA端子(插脚9) CH : 2 偏差仪滤波器 HPF : 关闭 LPF : 15kHz 去加重 : 关闭 AG频率 : 1kHz (正弦波) AG电平 : 280mV 发射	MOD ANA 或偏差仪 示波器 AG AF VTVM	后侧	TX天线 控制输入 /输出 TA端子 (插脚9)			PC调整 3.0kHz	$\pm 0.1\text{kHz}$
(窄)	2) CH : 2 发射						PC调整 1.5kHz	$\pm 0.05\text{kHz}$
27. TD 频偏调整 (宽)	1) 将AG输出插入控制输入/输出TD端子(插脚8) CH : 2 偏差仪滤波器 HPF : 关闭 LPF : 3kHz 去加重 : 关闭 AG频率 : 100Hz (正弦波) AG电平 : 0.5V _{p-p} (177mV _{rms}) 发射			控制输入 /输出 TD端子 (插脚8)			PC调整 0.75kHz	$\pm 0.1\text{kHz}$
(窄)	2) CH : 2 发射						PC调整 0.35kHz	$\pm 0.05\text{kHz}$

ADJUSTMENT

Item	Condition	Measurement			Adjustment			Specifications/Remarks																								
		Test-equipment	Unit	Terminal	Unit	Parts	Method																									
28. DTMF deviation (Wide)	1) CH : 2 Deviation meter filter HPF : OFF LPF : 15kHz De-emphasis : OFF Transmission	MOD ANA or Deviation meter Oscilloscope	Rear	TX ANT			PC adj. 3.0kHz	±0.1kHz																								
	(Narrow)							2) CH : 2 Transmission	PC adj. 1.5kHz	±0.05kHz																						
29. Courtesy tone deviation (Wide)	1) CH : 2 Deviation meter filter HPF : OFF LPF : 15kHz De-emphasis : OFF Transmission							MOD ANA or Deviation meter Oscilloscope	Rear	TX ANT			PC adj. 1.0kHz	±0.05kHz																		
	(Narrow)													2) CH : 2 Transmission	PC adj. 0.5kHz	±0.05kHz																
30. Battery warning tone deviation (Wide)	1) CH : 2 Deviation meter filter HPF : OFF LPF : 15kHz De-emphasis : OFF Transmission													MOD ANA or Deviation meter Oscilloscope	Rear	TX ANT			PC adj. 3.0kHz	±0.1kHz												
	(Narrow)																			2) CH : 2 Transmission	PC adj. 1.5kHz	±0.05kHz										
31. Battery operation tone deviation (Wide)	1) CH : 2 Deviation meter filter HPF : OFF LPF : 15kHz De-emphasis : OFF Transmission																			MOD ANA or Deviation meter Oscilloscope	Rear	TX ANT			PC adj. 1.0kHz	±0.05kHz						
	(Narrow)																									2) CH : 2 Transmission	PC adj. 0.5kHz	±0.05kHz				
32. Repeat gain level (Wide)	1) CH : 2 SSG output : -53dBm SSG MOD : 1kHz SSG DEV : 1kHz Deviation meter filter HPF : OFF LPF : 15kHz De-emphasis : OFF Transmission																									SSG MOD ANA or Deviation meter Oscilloscope	Rear	RX ANT			PC adj. 1kHz	±0.1kHz
	(Narrow)																											2) CH : 2 Transmission				
When "RF Power Down Detect" is programmed in the AUXO function, threshold of transmission output is set with the following menu.																																
33. Power down detect (High)	1) CH : 2 (High power)	Power meter	Rear	TX ANT			PC adj. About 16W (Factory-default)																									
	(Low)							2) CH : 2 (Low power)	PC adj. About 10W (Factory-default)																							

调 整

项 目	条 件	测 量			调 整			规 格 / 备 注						
		测量装置	单元	端子	单元	部件	方 法							
28. DTMF 频偏调整 (宽)	1) CH : 2 偏差仪滤波器 HPF : 关闭 LPF : 15kHz 去加重 : 关闭 发射	MOD ANA 或偏差仪 示波器	后侧	TX天线			PC调整 3.0kHz	± 0.1kHz						
	(窄)							2) CH : 2 发射	PC调整 1.5kHz	± 0.05kHz				
29. 发射停止 音频偏调整 (宽)	1) CH : 2 偏差仪滤波器 HPF : 关闭 LPF : 15kHz 去加重 : 关闭 发射							PC调整 1.0kHz	± 0.05kHz					
	(窄)							2) CH : 2 发射	PC调整 0.5kHz	± 0.05kHz				
30. 电池警告 音频偏调整 (宽)	1) CH : 2 偏差仪滤波器 HPF : 关闭 LPF : 15kHz 去加重 : 关闭 发射							PC调整 3.0kHz	± 0.1kHz					
	(窄)							2) CH : 2 发射	PC调整 1.5kHz	± 0.05kHz				
31. 电池 操作音 频偏调整 (宽)	1) CH : 2 偏差仪滤波器 HPF : 关闭 LPF : 15kHz 去加重 : 关闭 发射							PC调整 1.0kHz	± 0.05kHz					
	(窄)							2) CH : 2 发射	PC调整 0.5kHz	± 0.05kHz				
32. 中继增益 电平调整 (宽)	1) CH : 2 SSG输出 : - 53dBm SSG MOD : 1kHz SSG DEV : 1kHz 偏差仪滤波器 HPF : 关闭 LPF : 15kHz 去加重 : 关闭 发射							SSG MOD ANA 或偏差仪 示波器	后侧	RX天线 TX天线			PC调整 1kHz	± 0.1kHz
	(窄)													2) CH : 2 发射
当把“RF Power Down Detect”(RF功率下降检测)编程到AUXO功能时,发射输出的门槛值由下列菜单设定。														
33. 功率下降 检测调整 (高)	1) CH : 2 (高功率)							功率计	后侧	TX天线			PC调整 大约16W (出厂默认)	
	(低)	2) CH : 2 (低功率)	PC调整 大约10W (出厂默认)											

Confirmation and Alignment of Set-up to Prevent Receiver Desensitization

1. Confirmation of Duplexer alignment

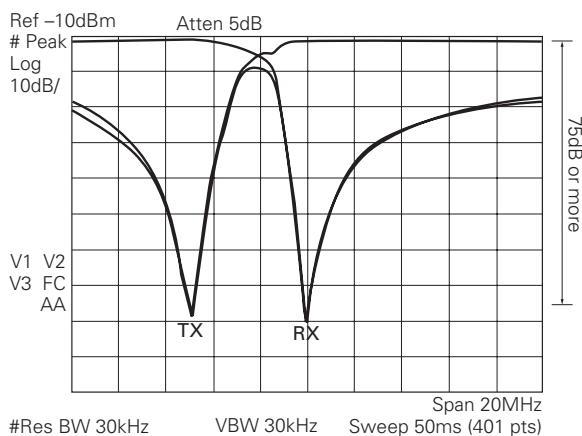
The duplexer allows the Repeater to simultaneously transmit and receive. To accomplish this, in the programmed receive frequency, the transmit frequency must be notched or suppressed by 75dB or more. Additionally, on the programmed transmit frequency, the receive frequency must be notched or suppressed by 75dB or more. The following figures are examples of Duplexer alignment using a spectrum analyzer.

2. Confirmation of Repeater Desensitization

The following figure is a Test set-up for Repeater Desensitization.

After this Test set-up is completed, confirm the Repeater Desensitization as mentioned below.

- 1) Disable the repeater mode.
- 2) Adjust the level of the RF generator until 12dB SINAD is reached.
- 3) Increase the output of the RF generator by 1dB. (This increases the SINAD.)
- 4) Enable the repeater mode.
- 5) Read the SINAD level. It should not drop below 12dB SINAD. If the SINAD is less than 12dB, check the tightness of the connectors and the tuning of duplexer.



设定中的确认和调整以防接收机灵敏度降低

1. 双工器调整の確認

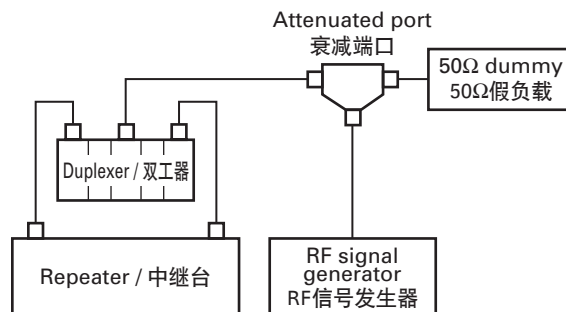
双工器允许中继台同时发送和接收。为实现该功能,对于编程的接收频率,发送频率必须抑制75dB或更高。另外,对于编程的发射频率,接收频率也必须抑制75dB或更高。下列图形就是一些利用频谱分析仪得到的双工器调整图例。

2. 中继台灵敏度降低の確認

下图是针对中继台灵敏度降低的测试调整。

当测试调整完成之后,如下所述确认中继台灵敏度降低的解决。

- 1) 停用中继台模式。
- 2) 调节RF发生器的电平直至达到12dB SINAD (信噪比)。
- 3) RF发生器的输出增加1dB。(该操作将会增加信噪比。)
- 4) 使用中继台模式。
- 5) 读取SINAD (信噪比) 值。它不应下降到低于12dB SINAD (信噪比)。如果该SINAD (信噪比) 值小于12dB,检查连接器的紧密度和双工器的调谐。



TERMINAL FUNCTION / 端子功能

Final Unit (X45-374X-XX)

Connector No.	Terminal No.	Terminal Name	I/O	Terminal function
CN1		DRV	I	TX driver input signal (Coaxial)
To X57 (A/2) TX-RX unit	1	TMP	O	High temperature detector signal output for fan action
	2	BUP	O	Main DC/BACKUP status output
	3	PDT	O	RF power down signal output
	4	FAS	I	Fan control signal input
	5	PC	I	TX power control signal input
	6	8T	I	8V input during transmission
	7	NC	-	Reserved
	8	GND	-	Ground
CN4		FAB	O	Power supply output for cooling fan
		FAG	O	Fan ground
CN5	1	E	-	Ground
	2	B	O	Power supply output
	3	B	O	Power supply output
CN6	1	Main DC	I	Power supply input (from Main DC terminal)
CN7	1	BACKUP	I	Power supply input (from BACKUP terminal)
CN8	1	GND	-	Ground

末级单元 (X45-374X-XX)

连接器号码	端子号码	端子名称	输入/输出	端子功能
CN1		DRV	输入	TX驱动器输入信号(同轴)
CN3 至X57 (A/2) TX-RX 单元	1	TMP	输出	高温探测器信号输出用于风扇动作
	2	BUP	输出	主DC/后备电源状态输出
	3	PDT	输出	射频功率下降信号输出
	4	FAS	输入	风扇控制信号输入
	5	PC	输入	TX功率控制信号输入
	6	8T	输入	发射时的8V输入
	7	NC	-	保留
	8	GND	-	接地
CN4		FAB	输出	冷却风扇的电源供电输出
		FAG	输出	风扇接地
CN5	1	E	-	接地
	2	B	输出	电源供电输出
	3	B	输出	电源供电输出
CN6	1	Main DC	输入	电源供电输入(来自主DC端子)
CN7	1	BACKUP	输入	电源供电输入(来自后备DC端子)
CN8	1	GND	-	接地

Display Unit (X54-3330-21) (A/2)

Connector No.	Terminal No.	Terminal Name	I/O	Terminal function
CN501 To X54 (B/2) display unit	1	HK	I	Hook detection input/RXD input
	2	MIC	I	MIC signal input
	3	MIG	-	MIC ground
	4	PTT	I/O	PTT input/TXD output
	5	GND	-	Ground
	6	NC	-	No connection
	7	SB	O	Power supply output after power switch
	8	NC	-	No connection
	9	GND	-	Ground
	10	5M	O	Common 5V output
	11	VLI	I	Volume control input for AF signal
CN502 To X57 (B/2) TX-RX unit control section	1	MIG	-	MIC ground
	2	MIC	O	MIC signal output
	3	VLI	O	Volume control output for AF signal
	4	5C	I	Common 5V input
	5	K4	I	KEY input 4
	6	K5	I	KEY input 5
	7	K2	O	KEY output 2
	8	K3	O	KEY output 3
	9	K1	O	KEY output 1
	10	HK/RXD	O	Hook detection output/RXD output
	11	SOE	I	Output enable for shift register
	12	PTT/TXD	I/O	PTT output/TXD input

显示单元 (X54-3330-21) (A/2)

连接器号码	端子号码	端子名称	输入/输出	端子功能
CN501 至X54 (B/2) 显示 单元	1	HK	输入	挂钩检测输入/RXD输入
	2	MIC	输入	麦克风信号输入
	3	MIG	-	麦克风接地
	4	PTT	输入/输出	PTT输入/TXD输出
	5	GND	-	接地
	6	NC	-	无连接
	7	SB	输出	电源开关之后的电源供电输出
	8	NC	-	无连接
	9	GND	-	接地
	10	5M	输出	公共5V输出
	11	VLI	输入	音频信号音量控制输入
CN502 至X57 (B/2) TX-RX 单元 控制 部分	1	MIG	-	麦克风接地
	2	MIC	输出	麦克风信号输出
	3	VLI	输出	音频信号音量控制输出
	4	5C	输入	公共5V输入
	5	K4	输入	键输入4
	6	K5	输入	键输入5
	7	K2	输出	键输出2
	8	K3	输出	键输出3
	9	K1	输出	键输出1
	10	HK/RXD	输出	挂钩检测输出/RXD输出
	11	SOE	输入	对于移位寄存器开启输出
	12	PTT/TXD	输入/输出	PTT输出/TXD输入

TERMINAL FUNCTION / 端子功能

Connector No.	Terminal No.	Terminal Name	I/O	Terminal function
	13	STB1	I	Strobe data for shift register
	14	CLK	I	Clock data input
	15	DAT	I	Serial data input
	16	PSW	O	Power switch output
	17	GND	-	Ground
	18	NC	-	No connection
	19	SB	I	Power supply input after power switch
	20	SB	I	Power supply input after power switch

连接器号码	端子号码	端子名称	输入/输出	端子功能
	13	STB1	输入	对于移位寄存器的选通数据
	14	CLK	输入	时钟数据输入
	15	DAT	输入	串行数据输入
	16	PSW	输出	电源开关输出
	17	GND	-	接地
	18	NC	-	无连接
	19	SB	输入	电源开关之后的电源供电输入
	20	SB	输入	电源开关之后的电源供电输入

Display Unit (X54-3330-21) (B/2)

Connector No.	Terminal No.	Terminal Name	I/O	Terminal function
CN601 To X54 (A/2) display unit	1	VLI	O	Volume control output for AF signal
	2	5M	I	Common 5V input
	3	GND	-	Ground
	4	NC	-	No connection
	5	SB	I	Power supply input after power switch
	6	NC	-	No connection
	7	GND	-	Ground
	8	PTT	I/O	PTT output/TXD input
	9	MIG	-	MIC ground
	10	MIC	O	MIC signal output
	11	HK	O	Hook detection output/RXD output
J601 (Mic jack)	1	NC	-	No connection
	2	SB	O	Power supply output after power switch
	3	GND	-	Ground
	4	PTT/TXD	I/O	PTT input/TXD output
	5	MIG	-	MIC ground
	6	MIC	I	MIC signal input
	7	HK/RXD	I	Hook detection input/RXD input
	8	NC	-	No connection

显示单元 (X45-3330-21) (B/2)

连接器号码	端子号码	端子名称	输入/输出	端子功能
CN601 至X54 (A/2) 显示 单元	1	VLI	输出	音频信号的音量控制输出
	2	5M	输入	公共5V输入
	3	GND	-	接地
	4	NC	-	无连接
	5	SB	输入	电源开关之后的电源供电输入
	6	NC	-	无连接
	7	GND	-	接地
	8	PTT	输入/输出	PTT输出/TXD输入
	9	MIG	-	麦克风接地
	10	MIC	输出	麦克风信号输出
	11	HK	输出	挂钩检测输出/RXD输出
J601 (麦克风 插孔)	1	NC	-	无连接
	2	SB	输出	电源开关之后的电源供电输出
	3	GND	-	接地
	4	PTT/TXD	输入/输出	PTT输入/TXD输出
	5	MIG	-	麦克风接地
	6	MIC	输入	麦克风信号输入
	7	HK/RXD	输入	挂钩检测输入/RXD输入
	8	NC	-	无连接

TX-RX Unit (X57-696X-XX) (A/2) : TX-RX Section

Connector No.	Terminal No.	Terminal Name	I/O	Terminal function
CN1	-	-	O	Use for RX helical BPF tuning (Coaxial)
CN2	-	-	I	Use for RX MCF tuning
CN3	-	-	O	Use for RX frequency adjustment (Coaxial)
CN4	-	-	O	Use for RX MCF tuning
CN14 To X57 (B/2) control section of TX-RX unit	1	NC	-	No connection
	2	DET	O	Detection signal output
	3	NC	-	No connection
	4	GND	-	Ground
	5	ASQ	O	Squelch signal output
	6	RSSI	O	RSSI signal output
	7	SC	O	Squelch control signal output
	8	DP	I	Data input for PLL
	9	CP	I	Clock input for PLL

TX-RX单元 (X57-696X-XX) (A/2) : TX-RX部分

连接器号码	端子号码	端子名称	输入/输出	端子功能
CN1	-	-	输出	用于RX螺旋BPF调谐(同轴)
CN2	-	-	输入	用于RX MCF调谐
CN3	-	-	输出	用于RX频率调整(同轴)
CN4	-	-	输出	用于RX MCF调谐
CN14 至X57 (B/2) TX-RX 单元 控制 部分	1	NC	-	无连接
	2	DET	输出	信号输出检测
	3	NC	-	无连接
	4	GND	-	接地
	5	ASQ	输出	静噪信号输出
	6	RSSI	输出	RSSI信号输出
	7	SC	输出	静噪控制信号输出
	8	DP	输入	PLL的数据输入
	9	CP	输入	PLL的时钟输入

TERMINAL FUNCTION / 端子功能

Connector No.	Terminal No.	Terminal Name	I/O	Terminal function	连接器号码	端子号码	端子名称	输入/输出	端子功能
	10	EPR	I	Enable input for RX PLL		10	EPR	输入	RX PLL的输入开启
	11	EPT	I	Enable input for TX PLL		11	EPT	输入	TX PLL的输入开启
	12	LDR	O	Lock detector for RX PLL		12	LDR	输出	RX PLL的锁定检测器
	13	LDT	O	Lock detector for TX PLL		13	LDT	输出	TX PLL的锁定检测器
	14	DT	I	Data input		14	DT	输入	数据输入
	15	CK	I	Clock input		15	CK	输入	时钟输入
	16	STB	I	Strobe input for shift register		16	STB	输入	移位检测器的选通输入
	17	FWD	O	RF power down signal output		17	FWD	输出	射频功率下降信号输出
	18	LD2	I	Latch data input for DA converter		18	LD2	输入	数/模变换器的锁存数据输入
	19	BUP	O	Backup signal output		19	BUP	输出	后备信号输出
	20	PSW	I	Power switch input		20	PSW	输入	电源开关输入
	21	TMP	O	High temperature detector signal output for fan action		21	TMP	输出	高温探测器信号输出用于风扇动作
	22	SOE	I	Output enable for shift register		22	SOE	输入	移位寄存器的输出开启
	23	GND	-	Ground		23	GND	-	接地
	24	MB	I	Modulation signal input for VCXO		24	MB	输入	VCXO的调制信号输入
	25	MO	I	Modulation signal input for VCO		25	MO	输入	VCO的调制信号输入
	26	GND	-	Ground		26	GND	-	接地
	27	GND	-	Ground		27	GND	-	接地
	28	QS	I	Data		28	QS	输入	数据
	29	NC	-	No connection		29	NC	-	无连接
	30	SB	O	Power supply output after power switch		30	SB	输出	电源开关之后的电源供电输出
	31	SB	O	Power supply output after power switch		31	SB	输出	电源开关之后的电源供电输出
	32	SB	O	Power supply output after power switch		32	SB	输出	电源开关之后的电源供电输出
	33	SB	O	Power supply output after power switch		33	SB	输出	电源开关之后的电源供电输出
	34	NC	-	No connection		34	NC	-	无连接
	35	8C	O	Common 8V output		35	8C	输出	公共8V输出
	36	8C	O	Common 8V output		36	8C	输出	公共8V输出
CN15	1	E	-	Earth	CN15	1	E	-	接地
	2	B	I	Power supply input		2	B	输入	电源供电输入
	3	B	I	Power supply input		3	B	输入	电源供电输入
CN16	1	GND	-	Ground	CN16	1	GND	-	接地
	2	NC	-	No connection		2	NC	-	无连接
To X45 final unit	3	8T	O	8V output during transmission	至X45 末级 单元	3	8T	输出	发射时的8V输出
	4	PC	O	TX power control signal output		4	PC	输出	TX电源控制信号输出
	5	FAS	O	Fan control signal output		5	FAS	输出	风扇控制信号输出
	6	PDT	I	RF power down signal input		6	PDT	输入	射频功率下降信号输入
	7	BUP	I	Main DC/BACKUP status input		7	BUP	输入	主DC/后备DC状态输入
	8	TMP	I	High temperature detector signal input for fan action		8	TMP	输入	高温探测器信号输出用于风扇动作
CN18	1	RX IN	I	Receive signal input (Coaxial)	CN18	1	RX IN	输入	接收信号输入(同轴)
CN19	1	DO	O	Transmission signal output (Coaxial)	CN19	1	DO	输出	发射信号输出(同轴)

TX-RX Unit (X57-696X-XX) (B/2) : Control Section

Connector No.	Terminal No.	Terminal Name	I/O	Terminal function
CN600	1	SB	O	Power supply output after power switch
To X54 (B/2)	2	SB	O	Power supply output after power switch
	3	GND	-	Ground

TX-RX单元 (X57-696X-XX) (B/2) : 控制部分

连接器号码	端子号码	端子名称	输入/输出	端子功能
CN600	1	SB	输出	电源开关之后的电源供电输出
至X54 (B/2)	2	SB	输出	电源开关之后的电源供电输出
	3	GND	-	接地

TERMINAL FUNCTION / 端子功能

Connector No.	Terminal No.	Terminal Name	I/O	Terminal function	
display unit	4	NC	-	No Connection	
	5	DAT	O	Serial data output	
	6	PSW	I	Power switch input	
	7	STB1	O	Strobe data for shift register	
	8	CLK	O	Clock data output	
	9	SOE	O	Output enable for shift register	
	10	TXD1	I/O	PTT input/TXD output	
	11	K1	I	KEY input 1	
	12	RXD1	I	Hook detection input/RXD input	
	13	K2	I	KEY input 2	
	14	K3	I	KEY input 3	
	15	K4	O	KEY output 4	
	16	K5	O	KEY output 5	
	17	VLI	I	Volume control input for AF signal.	
	18	5C	O	Common 5V output	
	19	MIG	-	MIC ground	
	20	MIC	I	MIC signal input	
	CN601 To optional board	1	TXO	O	MIC signal output to the board
		2	TXI	I	MIC signal input from the board
		3	RXO	O	RX audio signal output to the board
4		AC	O	Audio control signal output	
5		BC1	O	Scramble code output.	
6		BC2	O	Scramble code output.	
7		BC3	O	Scramble code output.	
8		BC4	O	Scramble code output.	
9		PTI	I	PTT signal input	
10		CLRC	O	Clear code for scramble	
11		RXI	I	RX audio signal input from the board	
12		PTO	O	PTT signal output	
13		NC	O	No connection	
14		GND	-	Ground	
CN602 To X57 (A/2) TX-RX unit	1	8C	I	Common 8V input	
	2	8C	I	Common 8V input	
	3	NC	-	No connection	
	4	SB	I	Power supply input after power switch	
	5	SB	I	Power supply input after power switch	
	6	SB	I	Power supply input after power switch	
	7	SB	I	Power supply input after power switch	
	8	NC	-	No connection	
	9	QS	O	Data	
	10	GND	-	Ground	
	11	GND	-	Ground	
	12	MO	O	Modulation signal output for VCO	
	13	MB	O	Modulation signal output for VCXO	
	14	GND	-	Ground	
	15	SOE	O	Output enable for shift register	
	16	TMP	I	High temperature detector signal input	
	17	PSW	O	Power switch output	
	18	BUP	I	Backup signal input	

连接器号码	端子号码	端子名称	输入/输出	端子功能	
显示单元	4	NC	-	无连接	
	5	DAT	输出	串行数据输出	
	6	PSW	输入	电源开关输入	
	7	STB1	输出	移位寄存器的选通数据	
	8	CLK	输出	时钟数据输出	
	9	SOE	输出	移位寄存器的输出开启	
	10	TXD1	输入/输出	PTT输入/TXD输出	
	11	K1	输入	键输入1	
	12	RXD1	输入	挂钩检测输入/RXD输入	
	13	K2	输入	键输入2	
	14	K3	输入	键输入3	
	15	K4	输出	键输出4	
	16	K5	输出	键输出5	
	17	VLI	输入	射频信号的音量控制输入	
	18	5C	输出	公共5V输出	
	19	MIG	-	麦克风接地	
	20	MIC	输入	麦克风信号输入	
	CN601 至可选板	1	TXO	输出	麦克风信号输出到板
		2	TXI	输入	从板来的麦克风信号输入
		3	RXO	输出	RX音频信号输出到板
4		AC	输出	音频控制信号输出	
5		BC1	输出	扰频代码输出	
6		BC2	输出	扰频代码输出	
7		BC3	输出	扰频代码输出	
8		BC4	输出	扰频代码输出	
9		PTI	输入	PTT信号输入	
10		CLRC	输出	扰频的清除代码	
11		RXI	输入	从板来的RX音频信号输入	
12		PTO	输出	PTT信号输出	
13		NC	输出	无连接	
14		GND	-	接地	
CN602 至X57 (A/2) TX-RX单元	1	8C	输入	公共8V输入	
	2	8C	输入	公共8V输入	
	3	NC	-	无连接	
	4	SB	输入	电源开关之后的电源供电输入	
	5	SB	输入	电源开关之后的电源供电输入	
	6	SB	输入	电源开关之后的电源供电输入	
	7	SB	输入	电源开关之后的电源供电输入	
	8	NC	-	无连接	
	9	QS	输出	数据	
	10	GND	-	接地	
	11	GND	-	接地	
	12	MO	输出	VCO的调制信号输出	
	13	MB	输出	VCXO的调制信号输出	
	14	GND	-	接地	
	15	SOE	输出	移位寄存器的输出开启	
	16	TMP	输入	高温检测器信号输入	
	17	PSW	输出	电源开关输出	
	18	BUP	输入	后备信号输入	

TERMINAL FUNCTION / 端子功能

Connector No.	Terminal No.	Terminal Name	I/O	Terminal function	连接器号码	端子号码	端子名称	输入/输出	端子功能
	19	LD2	O	Latch data output for DA converter		19	LD2	输出	数/模变换器的锁存数据输出
	20	FWD	I	RF power down signal input		20	FWD	输入	射频功率下降信号输入
	21	STB	O	Strobe output for shift register		21	STB	输出	移位寄存器的选通输出
	22	CK	O	Clock output		22	CK	输出	时钟输出
	23	DT	O	Data output		23	DT	输出	数据输出
	24	LDT	I	Lock detector for TX PLL		24	LDT	输入	TX PLL的锁定检测器
	25	LDR	I	Lock detector for RX PLL		25	LDR	输入	RX PLL的锁定检测器
	26	EPT	O	Enable output for TX PLL		26	EPT	输出	TX PLL的输出开启
	27	EPR	O	Enable output for RX PLL		27	EPR	输出	RX PLL的输出开启
	28	CP	O	Clock output for PLL		28	CP	输出	PLL的时钟输出
	29	DP	O	Data output for PLL		29	DP	输出	PLL的数据输出
	30	SC	I	Squelch control signal input		30	SC	输入	静噪控制信号输入
	31	RSSI	I	RSSI signal input		31	RSSI	输入	RSSI信号输入
	32	ASQ	I	Squelch signal input		32	ASQ	输入	静噪信号输入
	33	GND	-	Ground		33	GND	-	接地
	34	NC	-	No connection		34	NC	-	无连接
	35	DET	I	Detection signal input		35	DET	输入	检测信号输入
	36	NC	-	No connection		36	NC	-	无连接
CN603 To ACC 15 pin connector	1	SB	O	Power supply output after power switch	CN603 至ACC 15插脚 连接器	1	SB	输出	电源开关之后的电源供电输出
	2	SB	O	Power supply output after power switch		2	SB	输出	电源开关之后的电源供电输出
	3	GND	-	Ground		3	GND	-	接地
	4	GND	-	Ground		4	GND	-	接地
CN604 To ACC 15 pin connector	1	AO5	O	Auxiliary output 5 (FPU selectable)	CN604 至ACC 15插脚 连接器	1	AO5	输出	辅助输出5 (FPU可选)
	2	AO4	O	Auxiliary output 4 (FPU selectable)		2	AO4	输出	辅助输出4 (FPU可选)
	3	AO3	O	Auxiliary output 3 (FPU selectable)		3	AO3	输出	辅助输出3 (FPU可选)
	4	SPO	O	External speaker output		4	SPO	输出	外部扬声器输出
	5	SPO	O	External speaker output		5	SPO	输出	外部扬声器输出
	6	AO2	O	Auxiliary output 2 (FPU selectable)		6	AO2	输出	辅助输出2 (FPU可选)
	7	AO1	O	Auxiliary output 1 (FPU selectable)		7	AO1	输出	辅助输出1 (FPU可选)
	8	SPI	I	Internal speaker input		8	SPI	输入	内部扬声器输入
	9	RSSI	O	RSSI signal output		9	RSSI	输出	RSSI信号输出
	10	RD	O	RX data output		10	RD	输出	RX数据输出
	11	SPG	-	External speaker ground		11	SPG	-	外部扬声器接地
	12	SPG	-	External speaker ground		12	SPG	-	外部扬声器接地
CN605	1	SPO	O	Internal speaker AF output	CN605	1	SPO	输出	内部扬声器音频输出
	2	SPG	-	Internal speaker ground		2	SPG	-	内部扬声器接地
CN606 To ACC 25 pin D-sub connector	1	NC	-	No connection	CN606 至ACC 25插脚 D-sub 连接器	1	NC	-	无连接
	2	NC	-	No connection		2	NC	-	无连接
	3	SPM	I	Speaker mute signal input		3	SPM	输入	扬声器静音信号输入
	4	IO6	I/O	Programable I/O 6		4	IO6	输入/输出	可编程输入/输出6
	5	RXG	-	RX signal ground		5	RXG	-	RX信号接地
	6	IO5	I/O	Programable I/O 5		6	IO5	输入/输出	可编程输入/输出5
	7	RA	O	RX audio output (voice)		7	RA	输出	RX音频输出 (声音)
	8	IO4	I/O	Programable I/O 4		8	IO4	输入/输出	可编程输入/输出4
	9	RD	O	RX data output (voice & data)		9	RD	输出	RX数据输出 (声音和数据)
	10	IO3	I/O	Programable I/O 3		10	IO3	输入/输出	可编程输入/输出3
	11	TA	I	TX audio input (voice)		11	TA	输入	TX音频输入 (声音)
	12	IO2	I/O	Programable I/O 2		12	IO2	输入/输出	可编程输入/输出2
	13	TD	I	TX data input (data or signaling)		13	TD	输入	TX数据输入 (数据或信令)

TERMINAL FUNCTION / 端子功能

Connector No.	Terminal No.	Terminal Name	I/O	Terminal function
	14	IO1	I/O	Programable I/O 1
	15	DG	-	Control line ground
	16	TXG	-	TX signal ground
	17	AI3	I	Auxiliary input 3 (FPU selectable)
	18	NC	-	No connection
	19	AI2	I	Auxiliary input 2 (FPU selectable)
	20	SC	O	Squelch control output
	21	AI1	I	Auxiliary input 1 (FPU selectable)
	22	EPTT	I	External press-to-talk switch input
	23	TXD2	O	RS-232C output signal (for FPU)
	24	EMON	I	External monitor switch input
	25	RXD2	I	RS-232C input signal (for FPU)
	26	NC	-	No connection
	27	NC	-	No connection
	28	NC	-	No connection
	29	NC	-	No connection
	30	NC	-	No connection

连接器号码	端子号码	端子名称	输入/输出	端子功能
	14	IO1	输入/输出	可编程输入/输出1
	15	DG	-	控制线接地
	16	TXG	-	TX信号接地
	17	AI3	输入	辅助输入3 (FPU可选)
	18	NC	-	无连接
	19	AI2	输入	辅助输入2 (FPU可选)
	20	SC	输出	静噪控制输出
	21	AI1	输入	辅助输入1 (FPU可选)
	22	EPTT	输入	外部PTT开关输入
	23	TXD2	输出	RS-232C输出信号 (用于FPU)
	24	EMON	输入	外部监听开关输入
	25	RXD2	输入	RS-232C输入信号 (用于FPU)
	26	NC	-	无连接
	27	NC	-	无连接
	28	NC	-	无连接
	29	NC	-	无连接
	30	NC	-	无连接

RX VCO Unit (X58-480X-XX)

Connector No.	Terminal No.	Terminal Name	I/O	Terminal function
CN300	1	FIN	I	Prescaler RF signal input
	2	5C	I	Common 5V input
	3	LDR	O	Lock detector for RX PLL
	4	EPR	I	Enable input for RX PLL
	5	DP	I	Data input for PLL
	6	CP	I	Clock input for PLL
	7	REF	I	Reference frequency signal input
CN350	1	GND	-	Ground
	2	SRR	I	Switching signal input for RX VCO
	3	8CL	I	8V input through the ripple filter
	4	CV	I	RX PLL lock voltage
	5	9CL	I	9V input through the ripple filter
	6	NC	-	No connection
CN351	1	VO	O	RX VCO output
	2	GND	-	Ground

RX VCO单元 (X58-480X-XX)

连接器号码	端子号码	端子名称	输入/输出	端子功能
CN300	1	FIN	输入	预定标器射频信号输入
	2	5C	输入	公共5V输入
	3	LDR	输出	RX PLL的锁定检测器
	4	EPR	输入	RX PLL的输入开启
	5	DP	输入	PLL的数据输入
	6	CP	输入	PLL的时钟输入
	7	REF	输入	参照频率信号输入
CN350	1	GND	-	接地
	2	SRR	输入	RX VCO的切换信号输入
	3	8CL	输入	通过纹波滤波器的8V输入
	4	CV	输入	RX PLL锁定电压
	5	9CL	输入	通过纹波滤波器的9V输入
	6	NC	-	无连接
CN351	1	VO	输出	RX VCO输出
	2	GND	-	接地

TX VCO Unit (X58-481X-XX)

Connector No.	Terminal No.	Terminal Name	I/O	Terminal function
CN300	1	FIN	I	Prescaler RF signal input
	2	5C	I	Common 5V input
	3	LDT	O	Lock detector for TX PLL
	4	EPT	I	Enable input for TX PLL
	5	DP	I	Data input for PLL
	6	CP	I	Clock input for PLL
	7	REF	I	Reference frequency signal input
CN350	1	GND	-	Ground
	2	STT	I	Switching signal input for TX VCO

TX VCO单元 (X58-481X-XX)

连接器号码	端子号码	端子名称	输入/输出	端子功能
CN300	1	FIN	输入	预定标器射频信号输入
	2	5C	输入	公共5V输入
	3	LDT	输出	TX PLL的锁定检测器
	4	EPT	输入	TX PLL的输入开启
	5	DP	输入	PLL的数据输入
	6	CP	输入	PLL的时钟输入
	7	REF	输入	参照频率信号输入
CN350	1	GND	-	接地
	2	STT	输入	TX VCO的切换信号输入

TERMINAL FUNCTION / 端子功能

Connector No.	Terminal No.	Terminal Name	I/O	Terminal function
	3	8CL	I	8V input through the ripple filter
	4	CV	I	RX PLL lock voltage
	5	9CL	I	9V input through the ripple filter
	6	MO	I	Modulation signal input
CN351	1	VO	O	TX VCO output
	2	GND	-	Ground

连接器号码	端子号码	端子名称	输入/输出	端子功能
	3	8CL	输入	通过纹波滤波器的8V输入
	4	CV	输入	RX PLL锁定电压
	5	9CL	输入	通过纹波滤波器的9V输入
	6	MO	输入	调制信号输入
CN351	1	VO	输出	TX VCO输出
	2	GND	-	接地

ACC 25 pin D-sub Connector

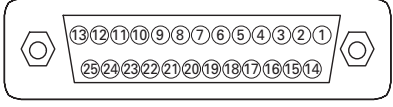
Connector No.	Terminal No.	Terminal Name	I/O	Terminal function
	1	NC	-	No connection
	2	RXD2	I	Serial data to radio
	3	TXD2	O	Serial data from radio
	4	AI1	I	Programmable function input 1
	5	AI2	I	Programmable function input 2
	6	AI3	I	Programmable function input 3
	7	DG	-	Control line ground
	8	TD	I	TX data input (data or signalling) Input impedance: 600Ω Coupling: AC coupling Deviation: 0.75kHz (wide)/ 0.35kHz (Narrow) (100Hz 0.5Vp-p input)
	9	TA	I	TX audio input (voice) Input impedance: 600Ω Coupling: AC coupling Frequency response: Pre-emphasis curve Deviation: 60% deviation (1kHz 280mVrms ±25mV input)
	10	RD	O	RX data output (voice & data) Output impedance: 1kΩ or less Coupling: AC coupling Non-squelched Frequency response: ±2.5dB at 10~3000Hz Output level: 70~90mVrms (standard modulation)
	11	RA	O	RX audio output (voice) Output impedance: 1kΩ or less Coupling: AC coupling Squelched Frequency response: De-emphasis curve Output level: 360~440mVrms (standard modulation)
	12	RXG	-	RX signal ground (for RA, RD ground only)

ACC25插脚D-sub连接器

连接器号码	端子号码	端子名称	输入/输出	端子功能
	1	NC	-	无连接
	2	RXD2	输入	至电台的串行数据
	3	TXD2	输出	来自电台的串行数据
	4	AI1	输入	可编程功能输入1
	5	AI2	输入	可编程功能输入2
	6	AI3	输入	可编程功能输入3
	7	DG	-	控制线接地
	8	TD	输入	TX数据输入 (数据或信令) 输入阻抗: 600欧姆 耦合: AC耦合 偏差: 0.75kHz (宽)/ 0.35kHz (窄) (100Hz 0.5Vp-p输入)
	9	TA	输入	TX音频输入 (声音) 输入阻抗: 600欧姆 耦合: AC耦合 频率响应: 预加重特性 偏差: 60%偏差 (1kHz 280mVrms ± 25mV输入)
	10	RD	输出	RX数据输出 (声音和数据) 输出阻抗: 1k欧姆或以下 耦合: AC耦合 无静噪 频率响应: 在10 ~ 3000Hz范围, ±2.5dB 输出电平: 70 ~ 90mVrms (标准调制)
	11	RA	输出	RX音频输出 (声音) 输出阻抗: 1k欧姆或以下 耦合: AC耦合 开启静噪 频率响应: 去加重特性 输出电平: 360 ~ 440mVrms (标准调制)
	12	RXG	-	RX信号接地 (仅对于RA, RD接地)

TERMINAL FUNCTION / 端子功能

Connector No.	Terminal No.	Terminal Name	I/O	Terminal function
	13	SPM	I	Speaker mute signal input “L”: Mute on
	14	NC	-	No connection
	15	EMON	I	External monitor switch input “L”: Monitor on, “H”: Monitor off
	16	EPTT	I	External press-to-talk switch input “L”: PTT on, “H”: PTT off
	17	SC	O	Squelch control output “L”: Busy, “H”: Not busy
	18	NC	-	No connection
	19	TXG	-	TX signal ground (for TA,TD ground only)
	20	AIO1	I/O	Programmable function input/output 1
	21	AIO2	I/O	Programmable function input/output 2
	22	AIO3	I/O	Programmable function input/output 3
	23	AIO4	I/O	Programmable function input/output 4
	24	AIO5	I/O	Programmable function input/output 5
	25	AIO6	I/O	Programmable function input/output 6

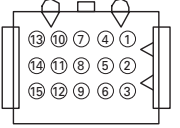


连接器号码	端子号码	端子名称	输入/输出	端子功能
	13	SPM	输入	扬声器静音信号输入 “L”: 静音接通
	14	NC	-	无连接
	15	EMON	输入	外部监听开关输入 “L”: 监听接通, “H”: 监听切断
	16	EPTT	输入	外部PTT开关输入 “L”: PTT接通, “H”: PTT切断
	17	SC	输出	静噪控制输出 “L”: 占用, “H”: 非占用
	18	NC	-	无连接
	19	TXG	-	TX信号接地 (仅对于TA, TD)
	20	AIO1	输入/输出	可编程功能输入/输出1
	21	AIO2	输入/输出	可编程功能输入/输出2
	22	AIO3	输入/输出	可编程功能输入/输出3
	23	AIO4	输入/输出	可编程功能输入/输出4
	24	AIO5	输入/输出	可编程功能输入/输出5
	25	AIO6	输入/输出	可编程功能输入/输出6



ACC 15 pin Connector

Connector No.	Terminal No.	Terminal Name	I/O	Terminal function
	1	SB	O	Power supply output after power switch; 1A maximum
	2	SB	O	Power supply output after power switch; 1A maximum
	3	NC	-	No connection
	4	GND	-	Ground
	5	GND	-	Ground
	6	SPG	-	Speaker ground
	7	RD	O	RX data output (Equal to D-sub connector terminal No. 10.)
	8	RSSI	O	RSSI output (Analog signal output)
	9	SPI	I	Internal speaker input
	10	AO1	O	Auxiliary output 1 Open collector. Low : 150mA max.
	11	AO2	O	Auxiliary output 2 Open collector. Low : 150mA max.
	12	SPO	O	External speaker output
	13	AO3	O	Auxiliary output 3
	14	AO4	O	Auxiliary output 4
	15	AO5	O	Auxiliary output 5

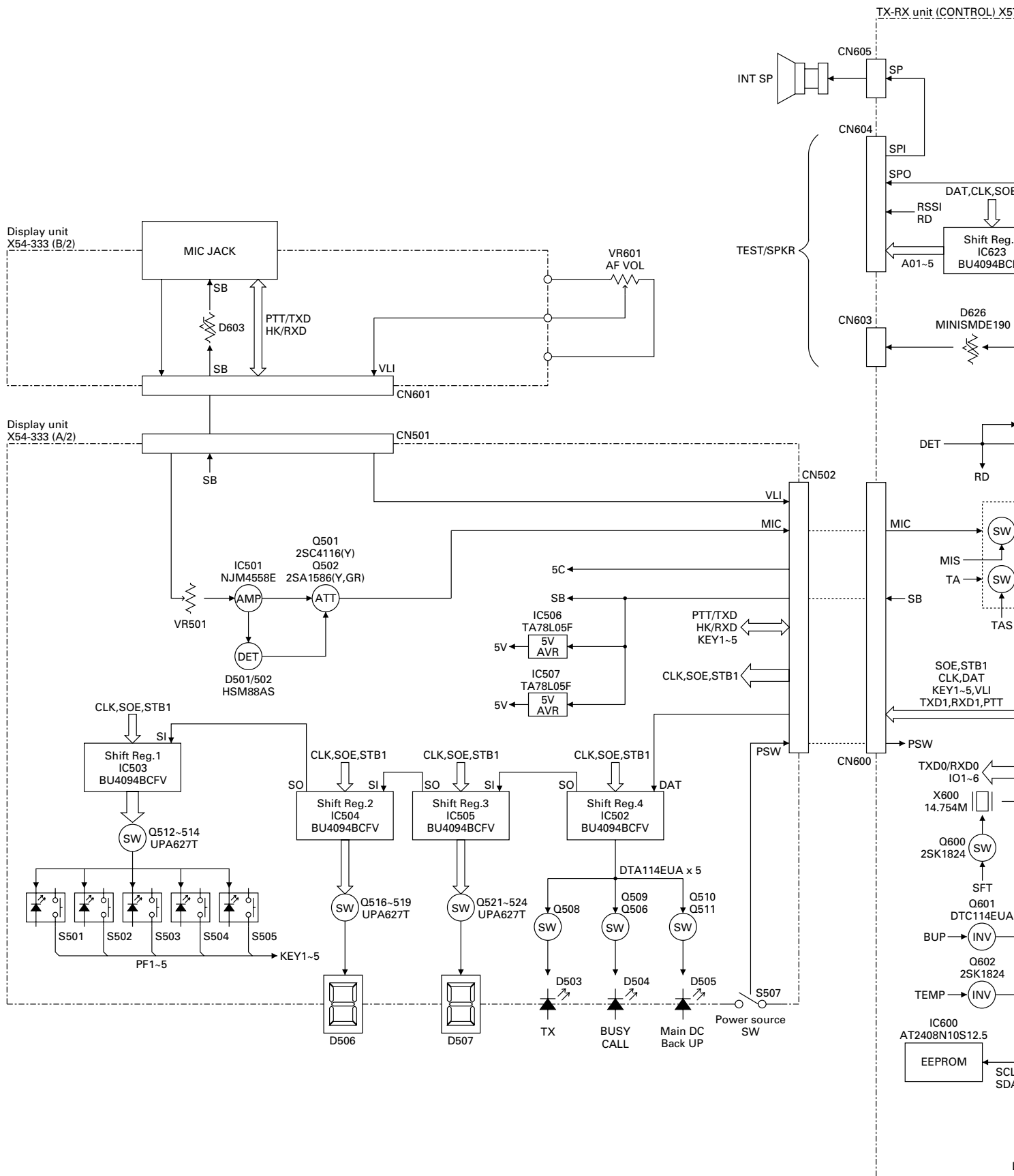


ACC 15插脚连接器

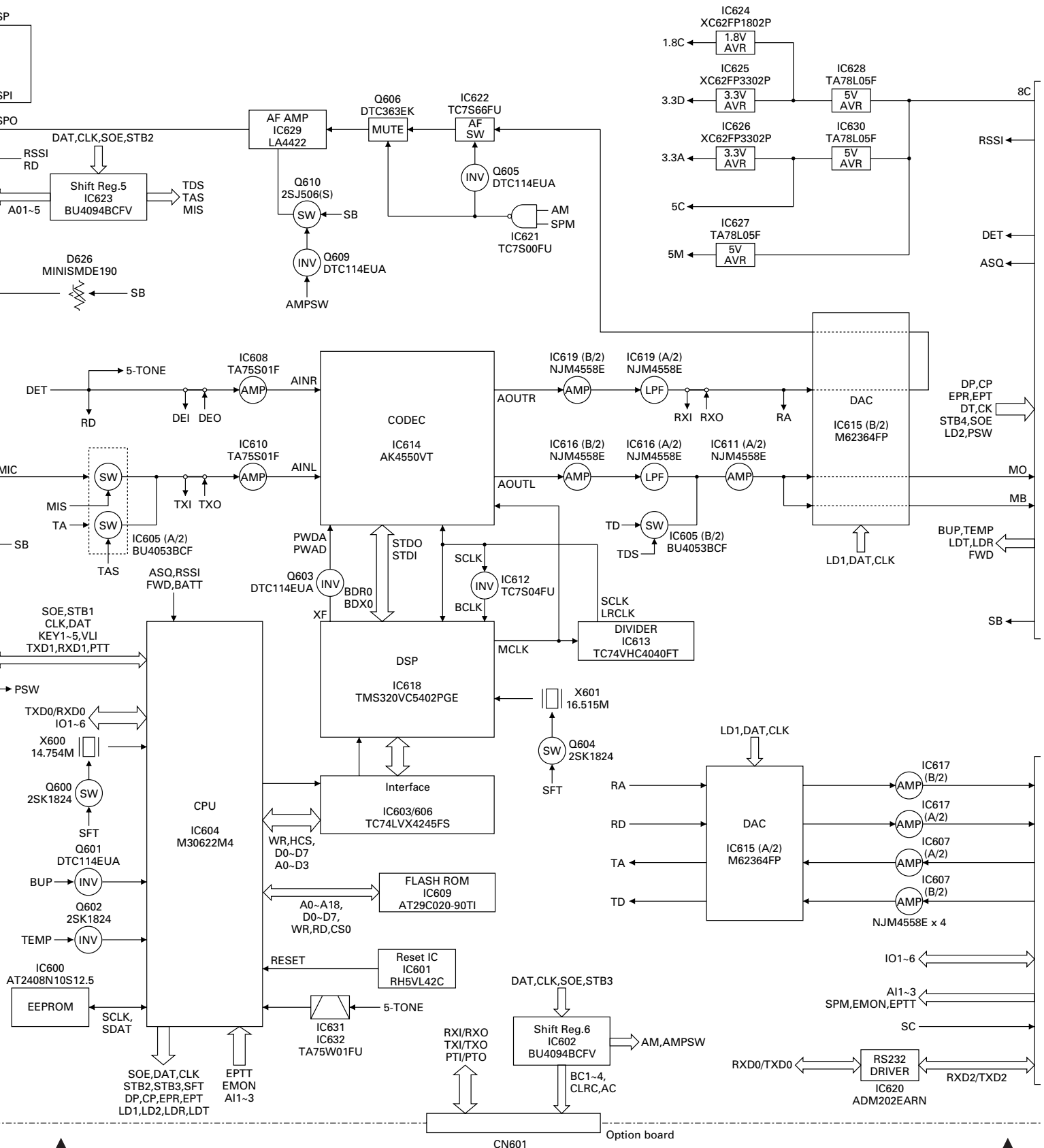
连接器号码	端子号码	端子名称	输入/输出	端子功能
	1	SB	输出	电源开关之后的电源供电输出, 最大1A
	2	SB	输出	电源开关之后的电源供电输出, 最大1A
	3	NC	-	无连接
	4	GND	-	接地
	5	GND	-	接地
	6	SPG	-	扬声器接地
	7	RD	输出	RX数据输出
	8	RSSI	输出	RSSI输出 (模拟信号输出)
	9	SPI	输入	内部扬声器输入
	10	AO1	输出	辅助输出1 集电极开路。低: 最大150mA
	11	AO2	输出	辅助输出2 集电极开路。低: 最大150mA
	12	SPO	输出	外部扬声器输出
	13	AO3	输出	辅助输出3
	14	AO4	输出	辅助输出4
	15	AO5	输出	辅助输出5



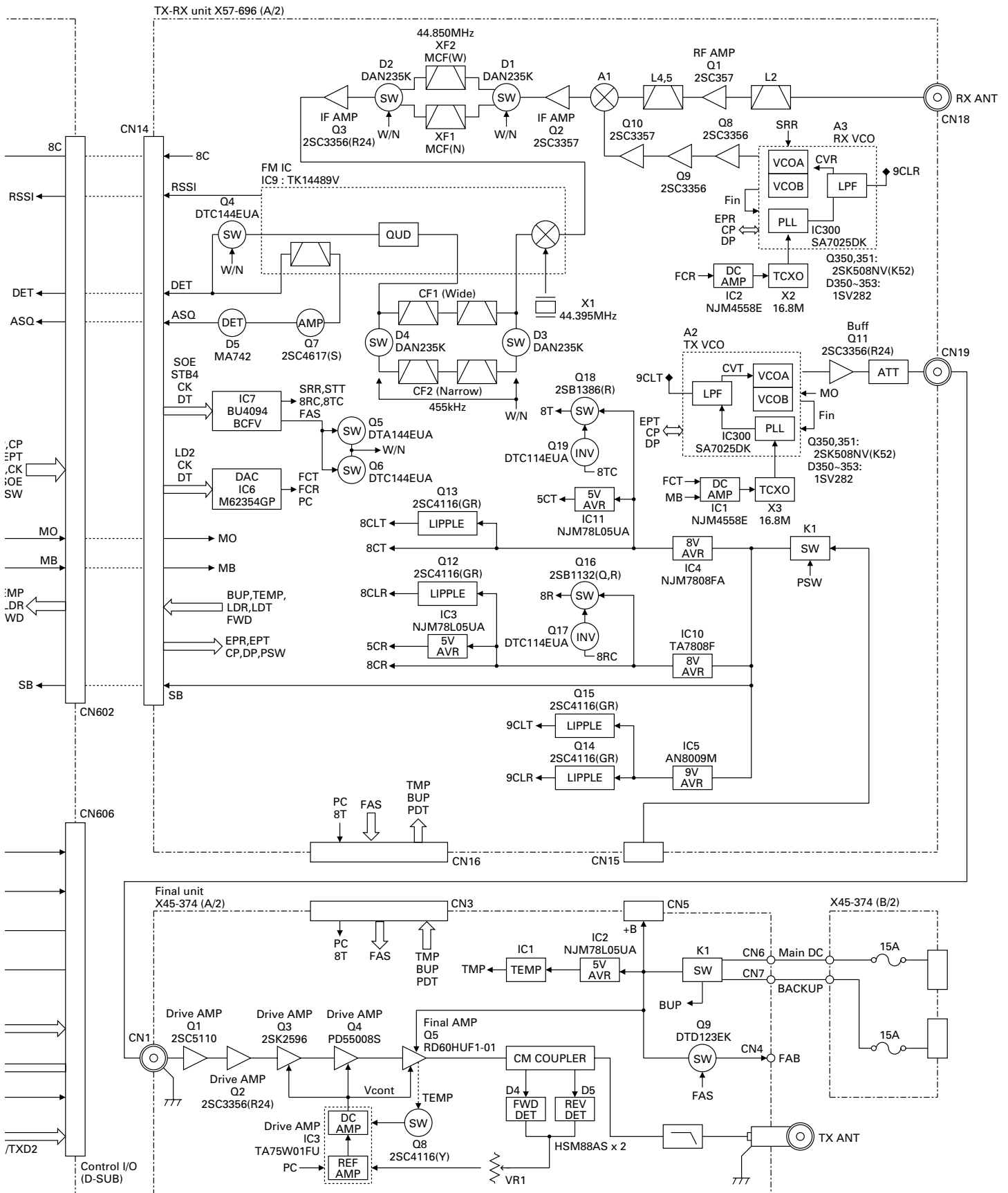
BLOCK DIAGRAM / 方块图



RX unit (CONTROL) X57-696 (B/2)

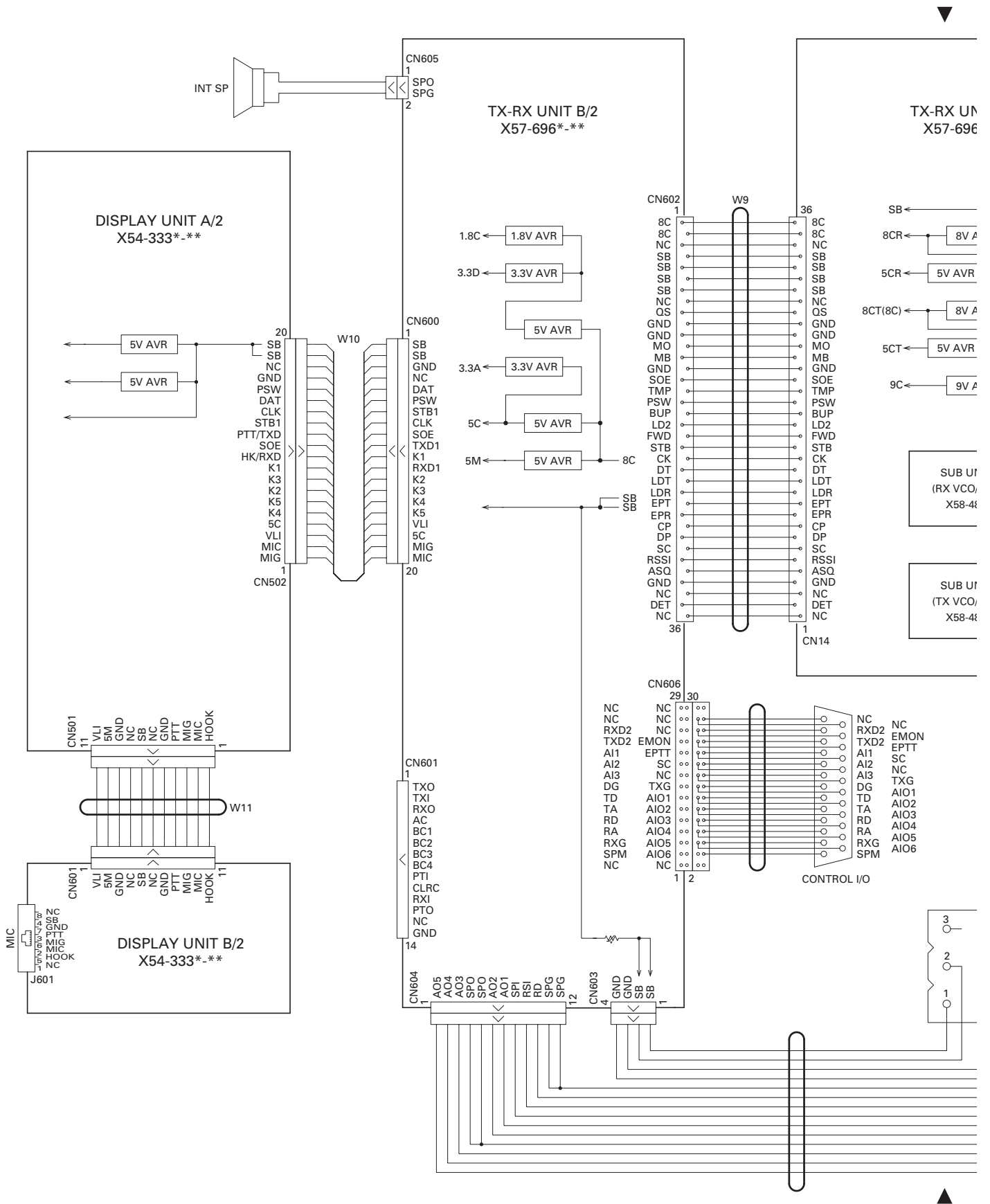


BLOCK DIAGRAM / 方块图

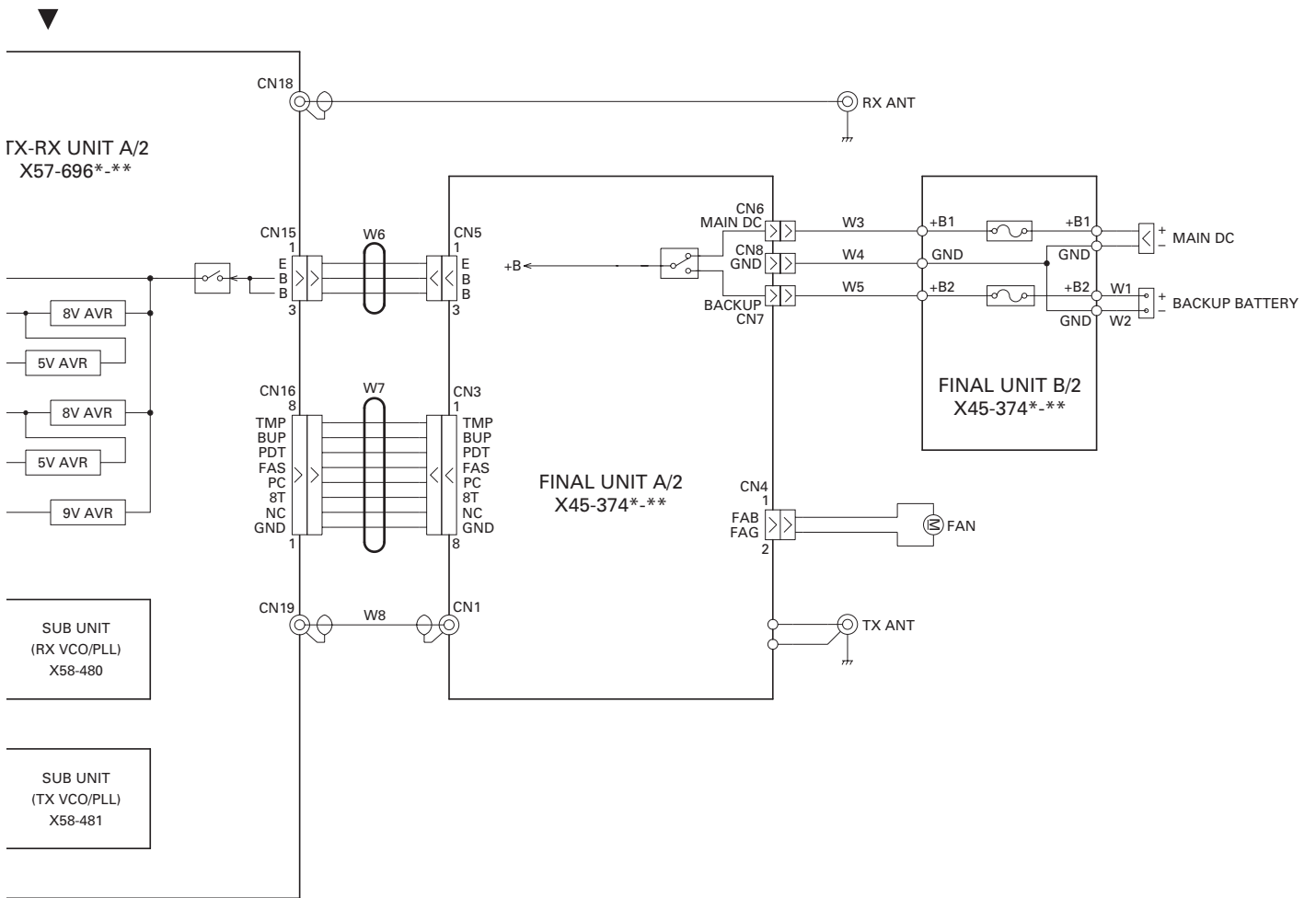


TKR-850

INTERCONNECTION DIAGRAM / 总布线图

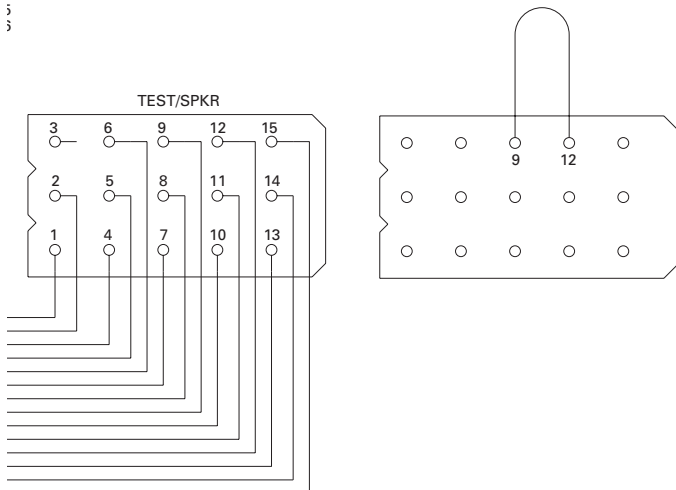


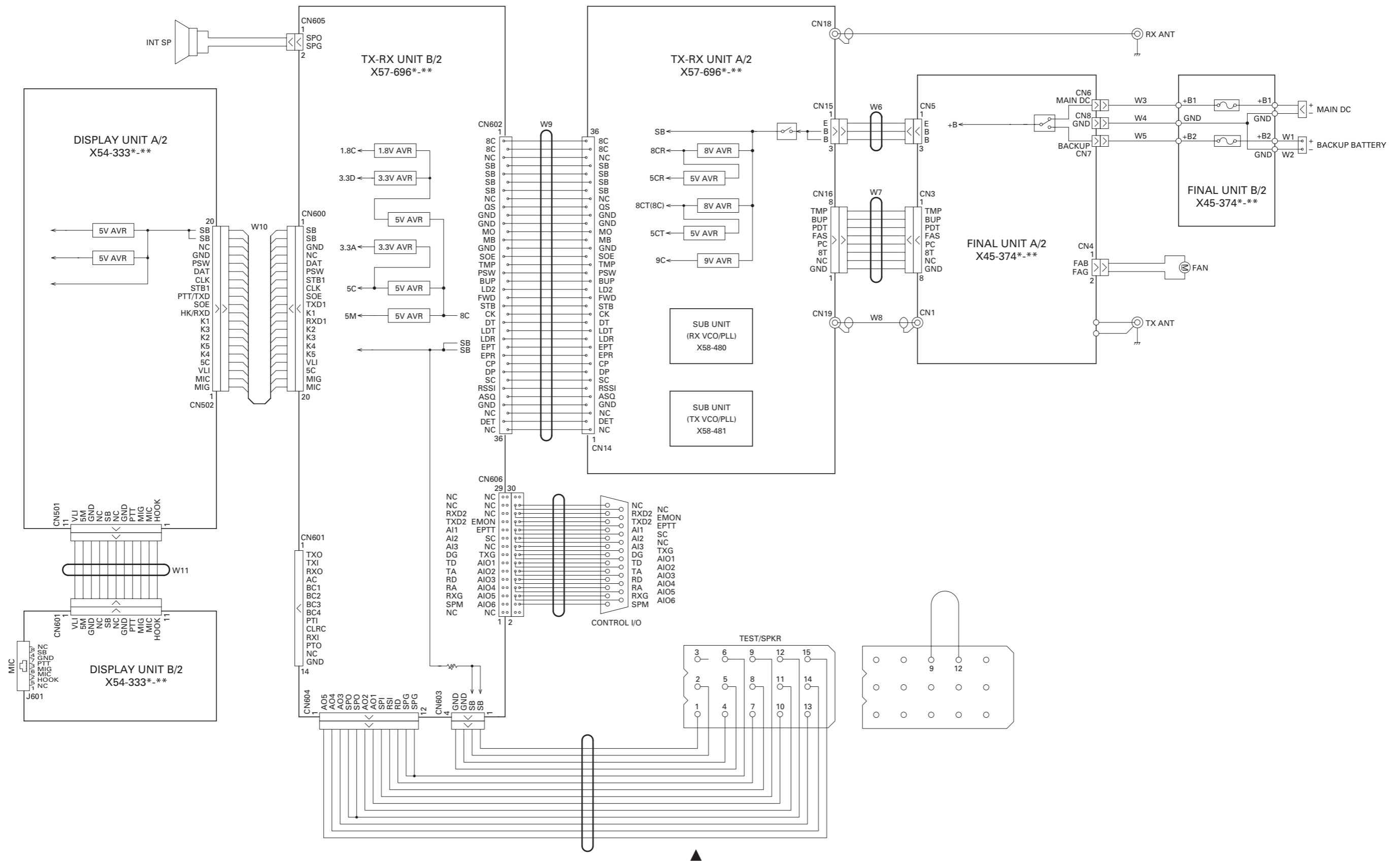
INTERCONNECTION DIAGRAM / 总布线图



IN
Γ

- 1
- 2
- 3
- 4
- 5
- 5





DISPLAY UNIT A/2
X54-333*-.**

TX-RX UNIT B/2
X57-696*-.**

TX-RX UNIT A/2
X57-696*-.**

FINAL UNIT A/2
X45-374*-.**

FINAL UNIT B/2
X45-374*-.**

SUB UNIT
(RX VCO/PLL)
X58-480

SUB UNIT
(TX VCO/PLL)
X58-481

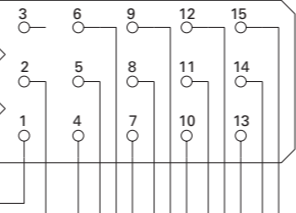
DISPLAY UNIT B/2
X54-333*-.**

CN606

NC	NC	29	30	NC	NC
NC	NC	EMON	EMON	NC	RXD2
RXD2	NC	A11	A11	NC	TXD2
TXD2	NC	A12	A12	NC	EPTT
A11	SC	A13	A13	NC	SC
A12	NC	DG	DG	TXG	TXG
A13	NC	TD	TD	AIO1	AIO1
DG	TXG	TA	TA	AIO2	AIO2
TD	AIO1	RD	RD	AIO3	AIO3
TA	AIO2	RA	RA	AIO4	AIO4
RD	AIO3	RXG	RXG	AIO5	AIO5
RA	AIO4	NC	NC	AIO6	AIO6
RXG	AIO5				
SPM	AIO6				
NC	NC				

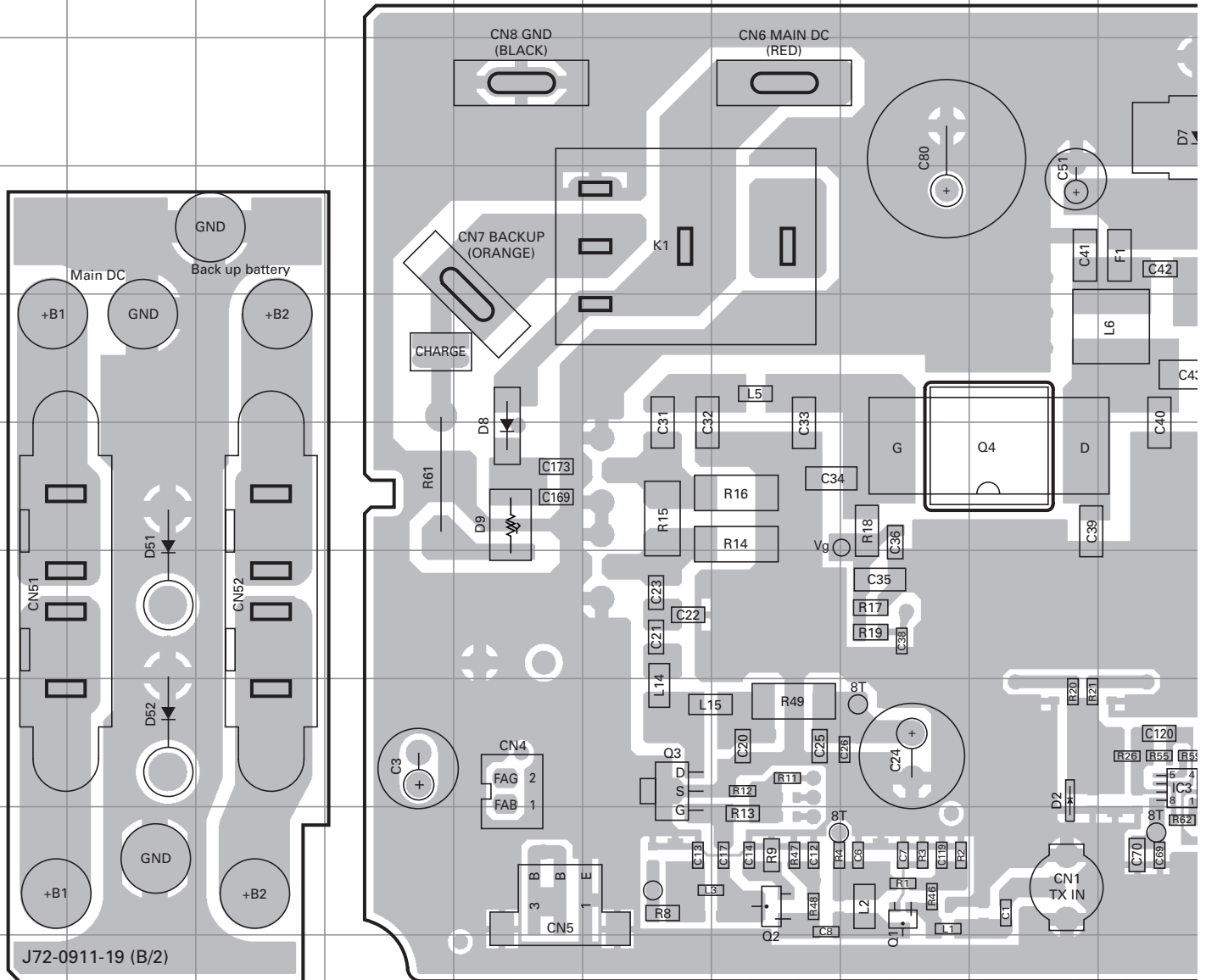
CONTROL I/O

TEST/SPKR



TKR-850 PC BOARD / PC板

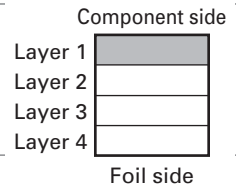
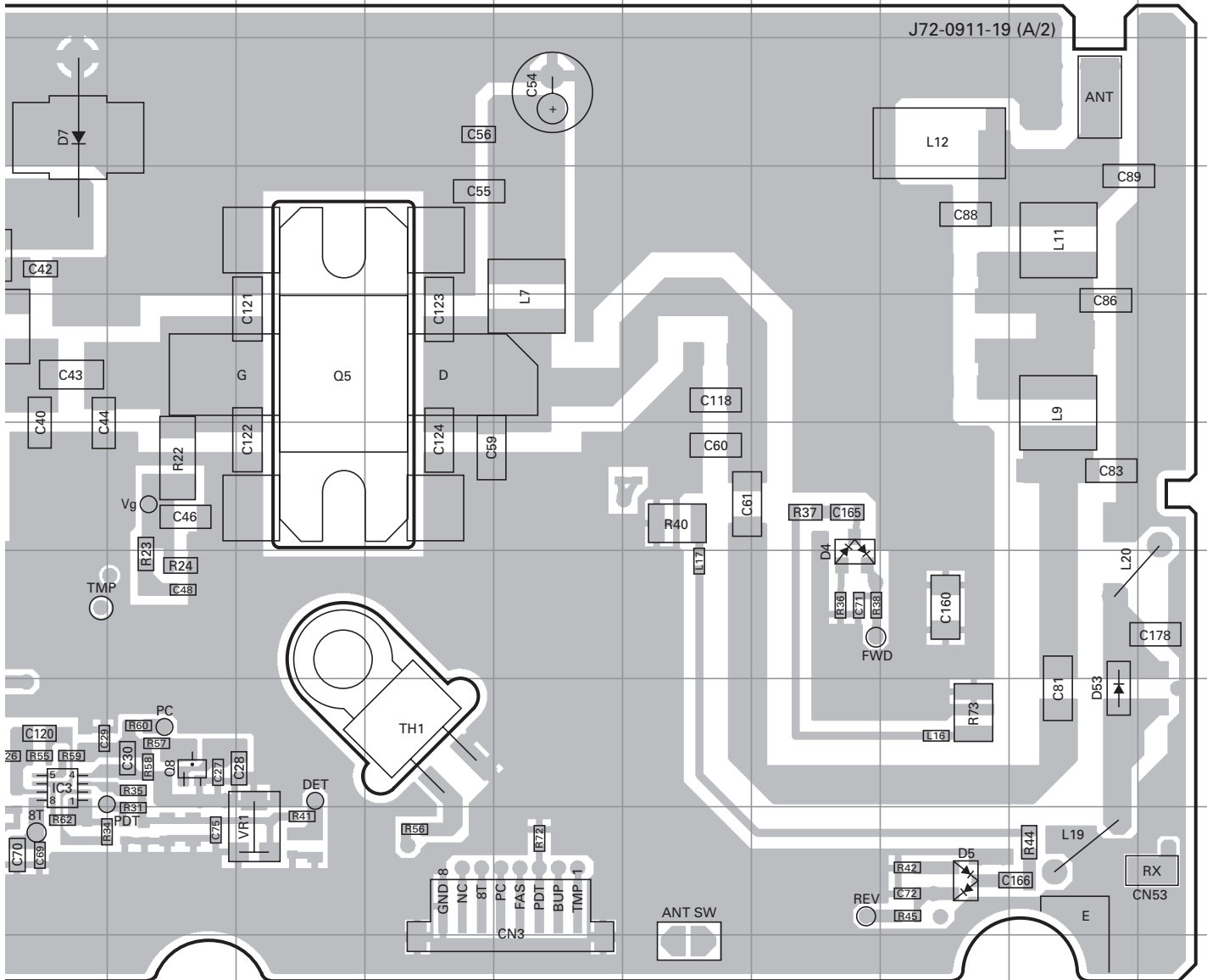
FINAL UNIT (X45-374X-XX) 0-10 : C 0-12 : C3 3-01 : C6
 Component side view (J72-0911-19)



Ref. No.	Address	Ref. No.	Address	Ref. No.	Address	Ref. No.	Address
IC3	8J	Q4	6I	D4	7P	D9	6E
Q1	9H	Q5	5L	D5	9Q	D51	7B
Q2	9G	Q8	8K	D7	3J	D52	8B
Q3	8F	D2	8I	D8	6E	D53	8R

PC BOARD / PC板 TKR-850

FINAL UNIT (X45-374X-XX) 0-10 : C 0-12 : C3 3-01 : C6
 Component side view (J72-0911-19)

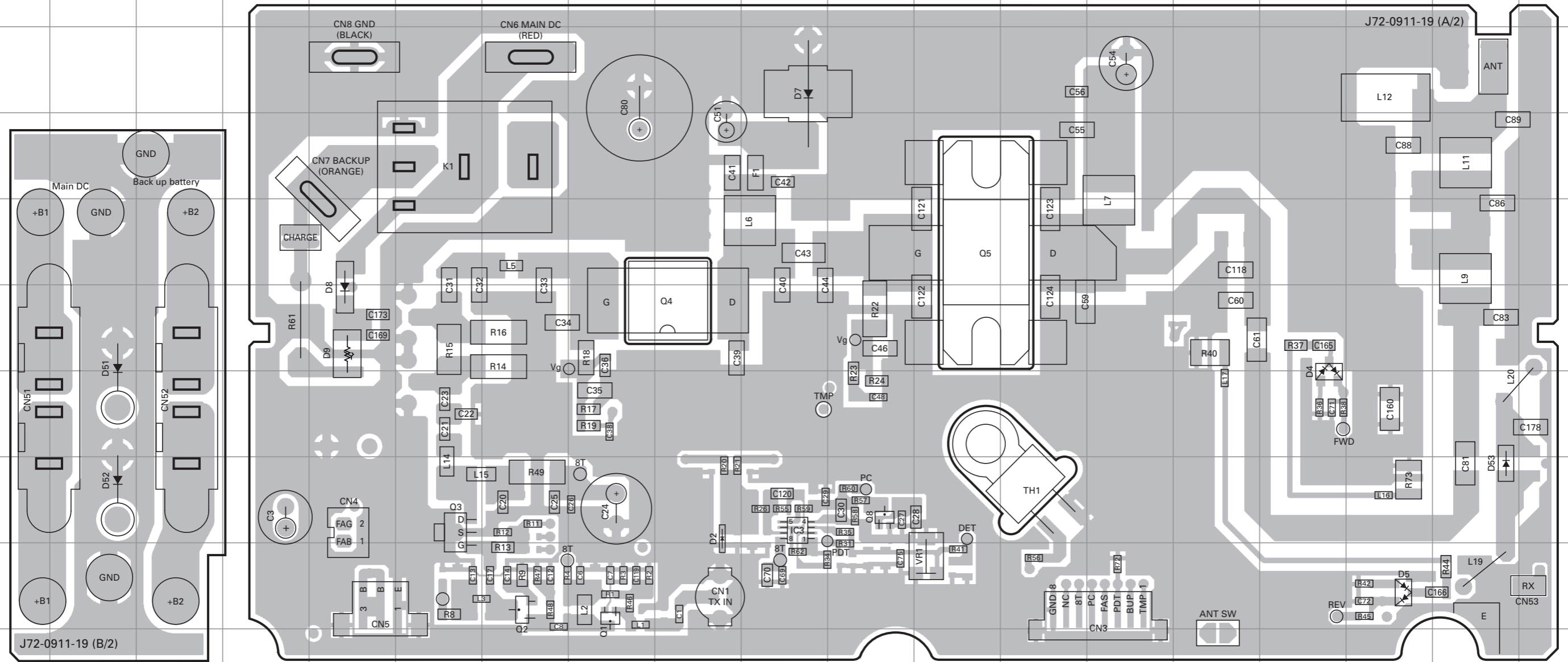


TKR-850 PC BOARD / PC板

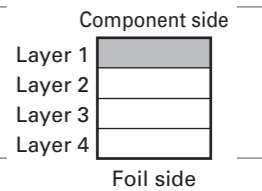
PC BOARD / PC板 TKR-850

FINAL UNIT (X45-374X-XX) 0-10 : C 0-12 : C3 3-01 : C6
Component side view (J72-0911-19)

FINAL UNIT (X45-374X-XX) 0-10 : C 0-12 : C3 3-01 : C6
Component side view (J72-0911-19)

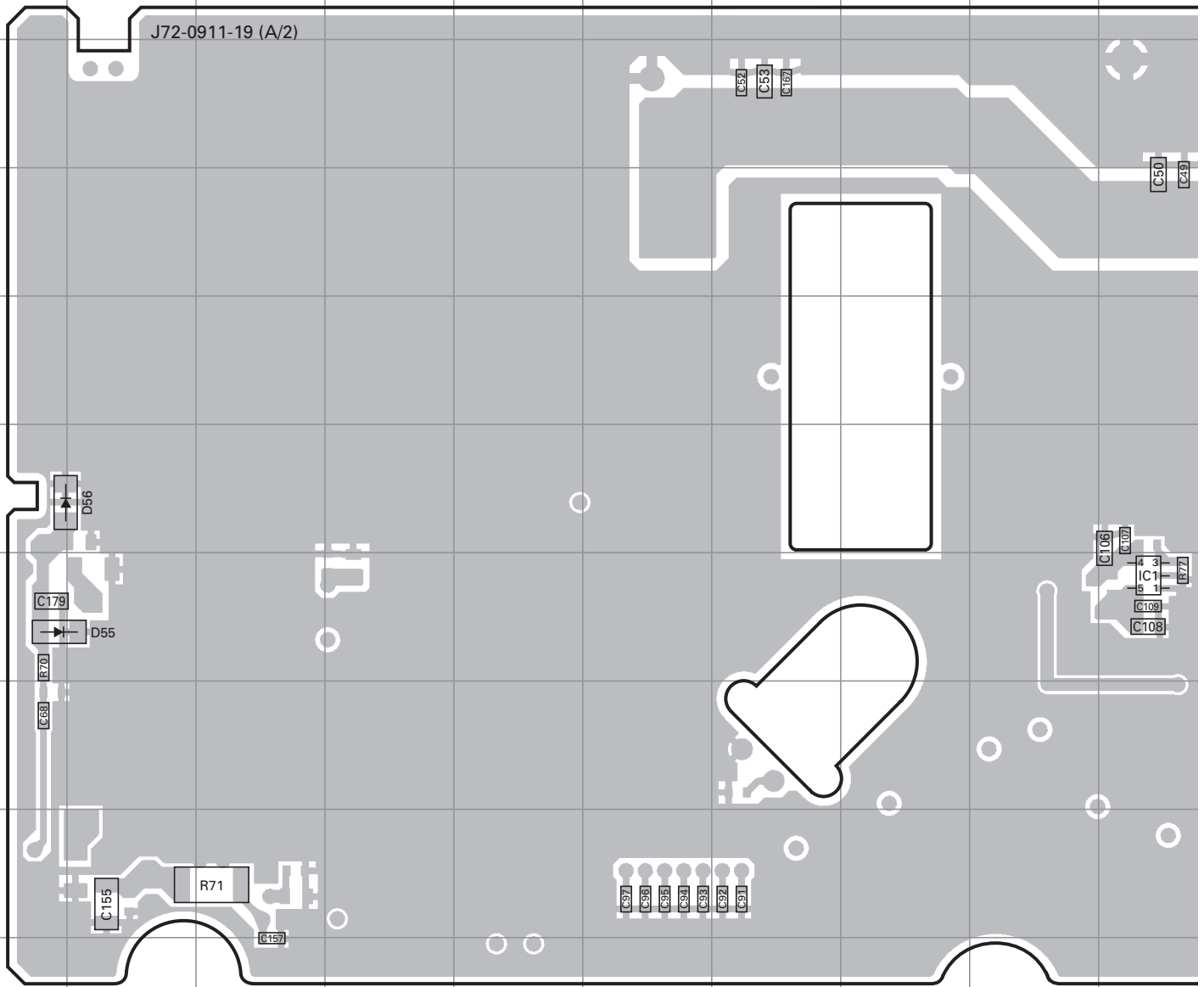


Ref. No.	Address	Ref. No.	Address	Ref. No.	Address	Ref. No.	Address
IC3	8J	Q4	6I	D4	7P	D9	6E
Q1	9H	Q5	5L	D5	9Q	D51	7B
Q2	9G	Q8	8K	D7	3J	D52	8B
Q3	8F	D2	8I	D8	6E	D53	8R



TKR-850 PC BOARD / PC板

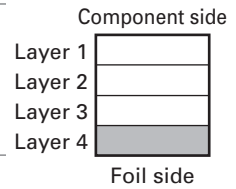
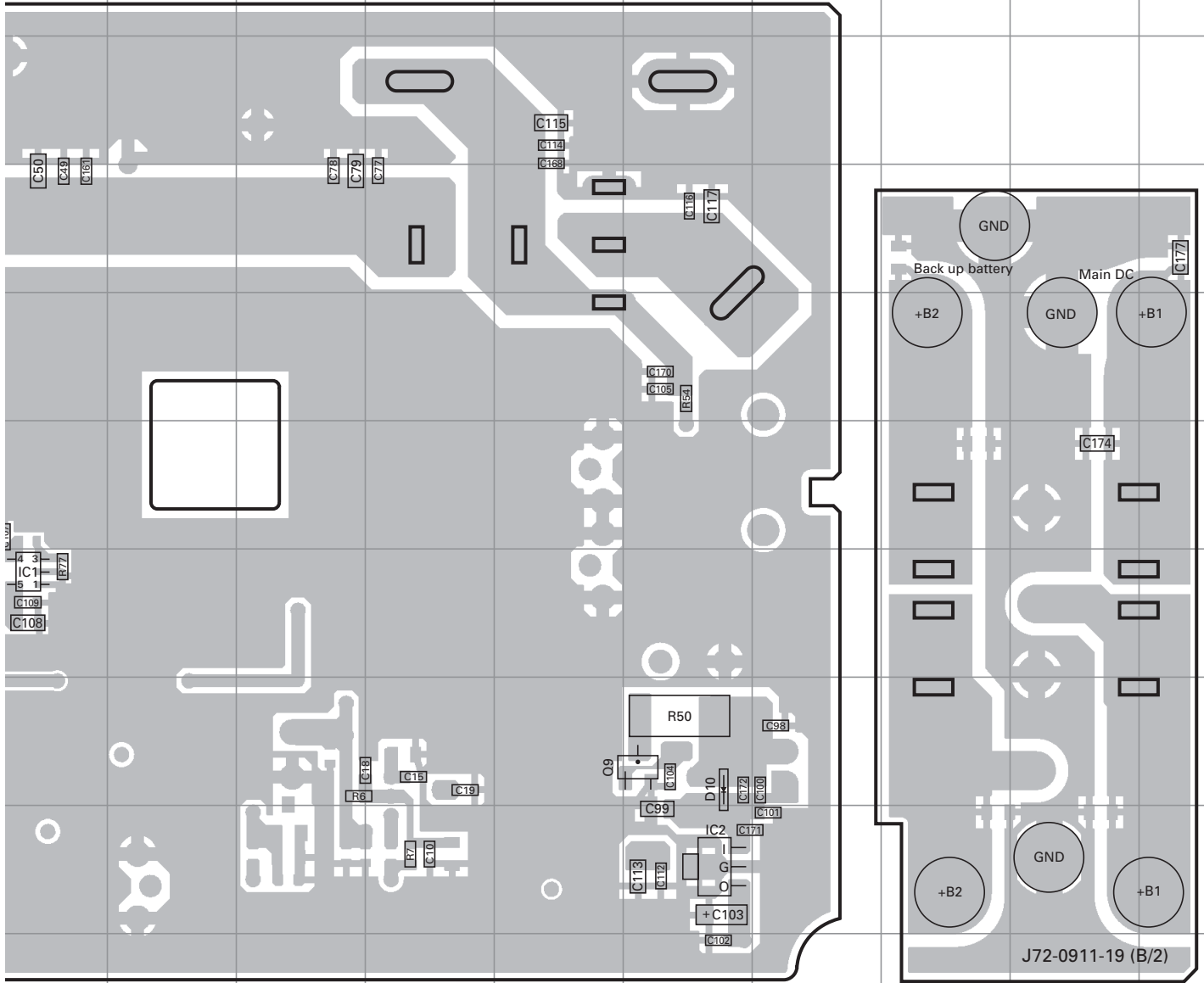
FINAL UNIT (X45-374X-XX) 0-10 : C 0-12 : C3 3-01 : C6
 Foil side view (J72-0911-19)



Ref. No.	Address	Ref. No.	Address
IC1	7J	D55	6A
IC2	9O	D56	7A
Q9	8O		
D10	8O		

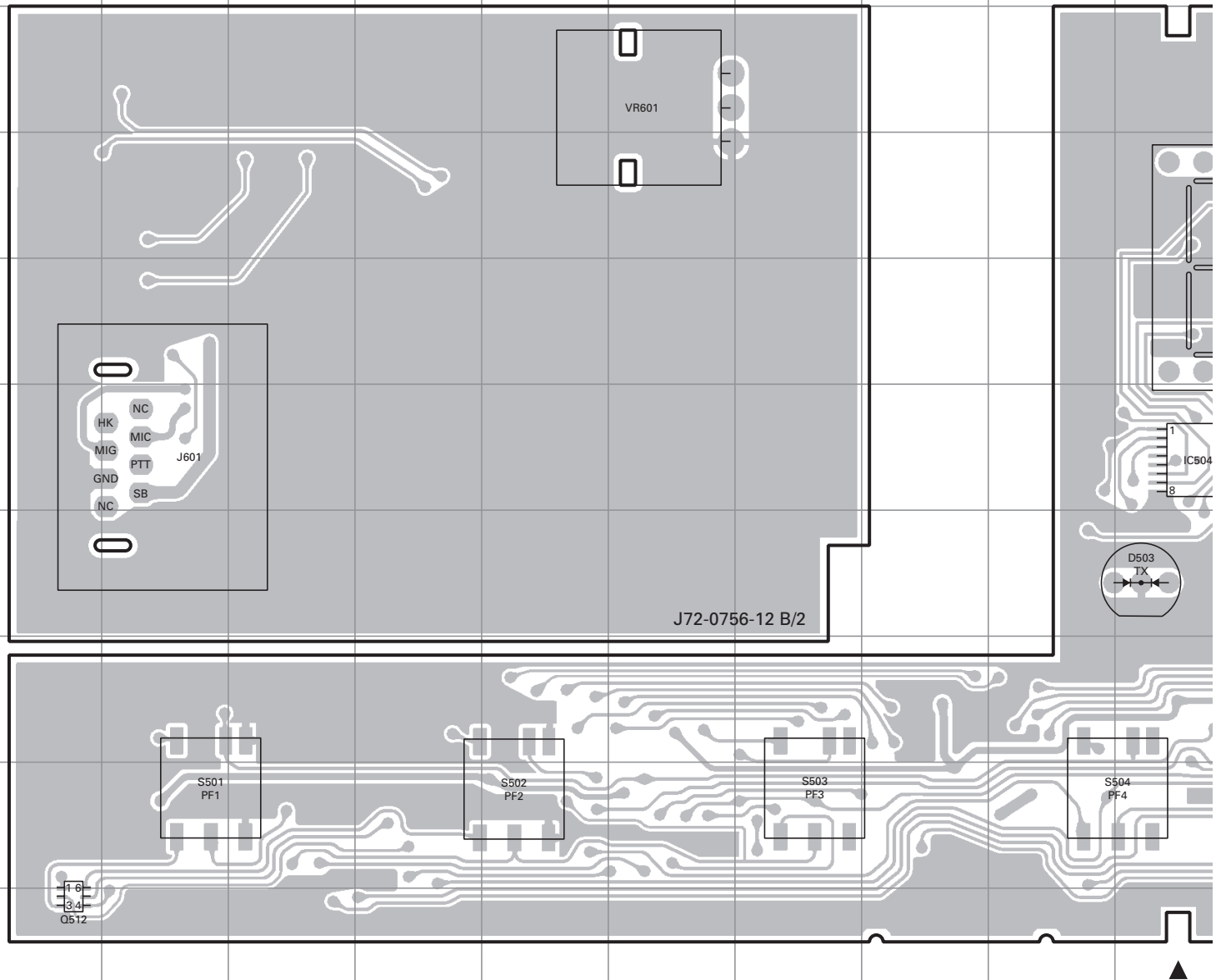
PC BOARD / PC板 TKR-850

FINAL UNIT (X45-374X-XX) 0-10 : C 0-12 : C3 3-01 : C6
Foil side view (J72-0911-19)



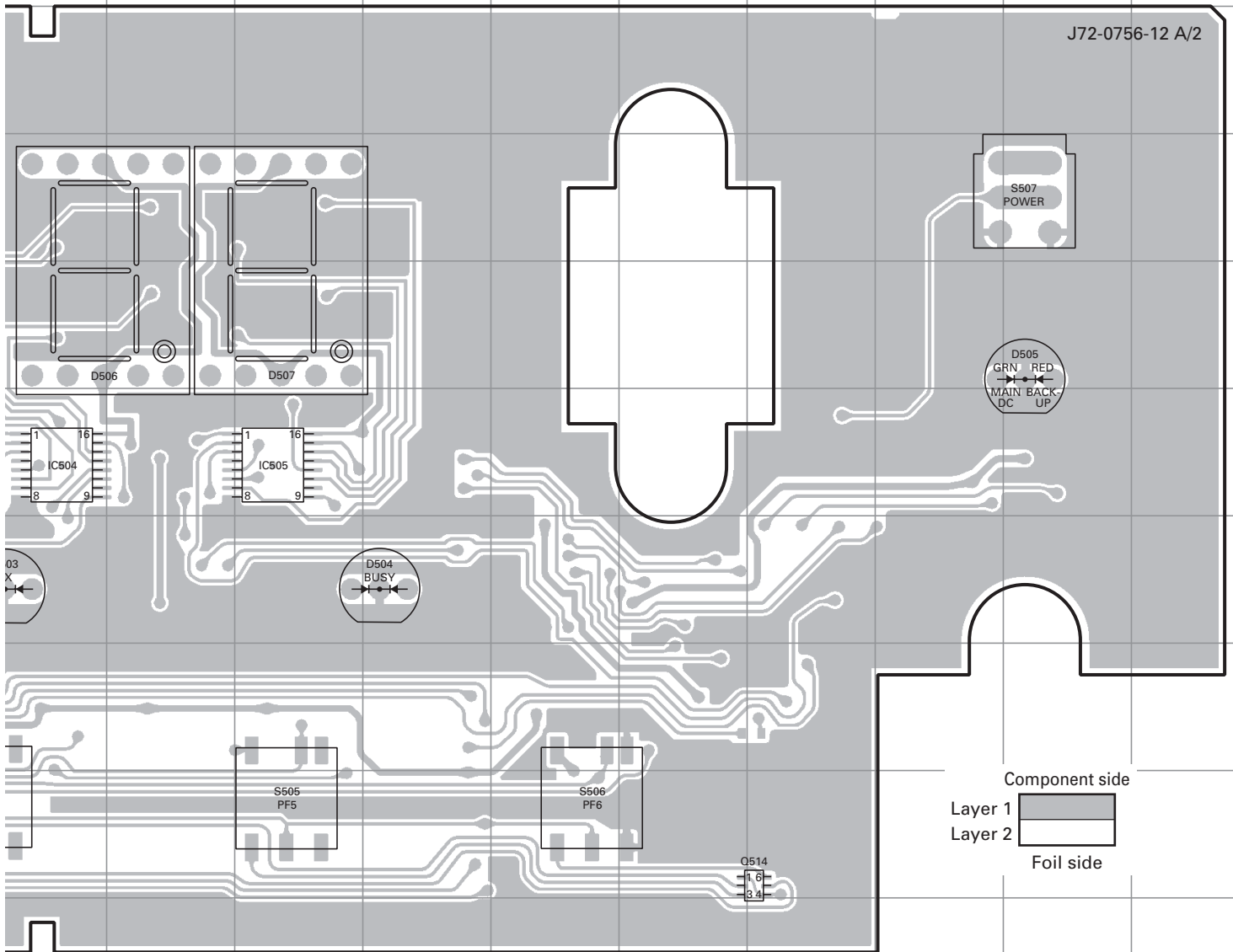
TKR-850 PC BOARD / PC板

DISPLAY UNIT (X54-3330-21) Component side view (J72-0756-12)



PC BOARD / PC板 TKR-850

DISPLAY UNIT (X54-3330-21) Component side view (J72-0756-12)



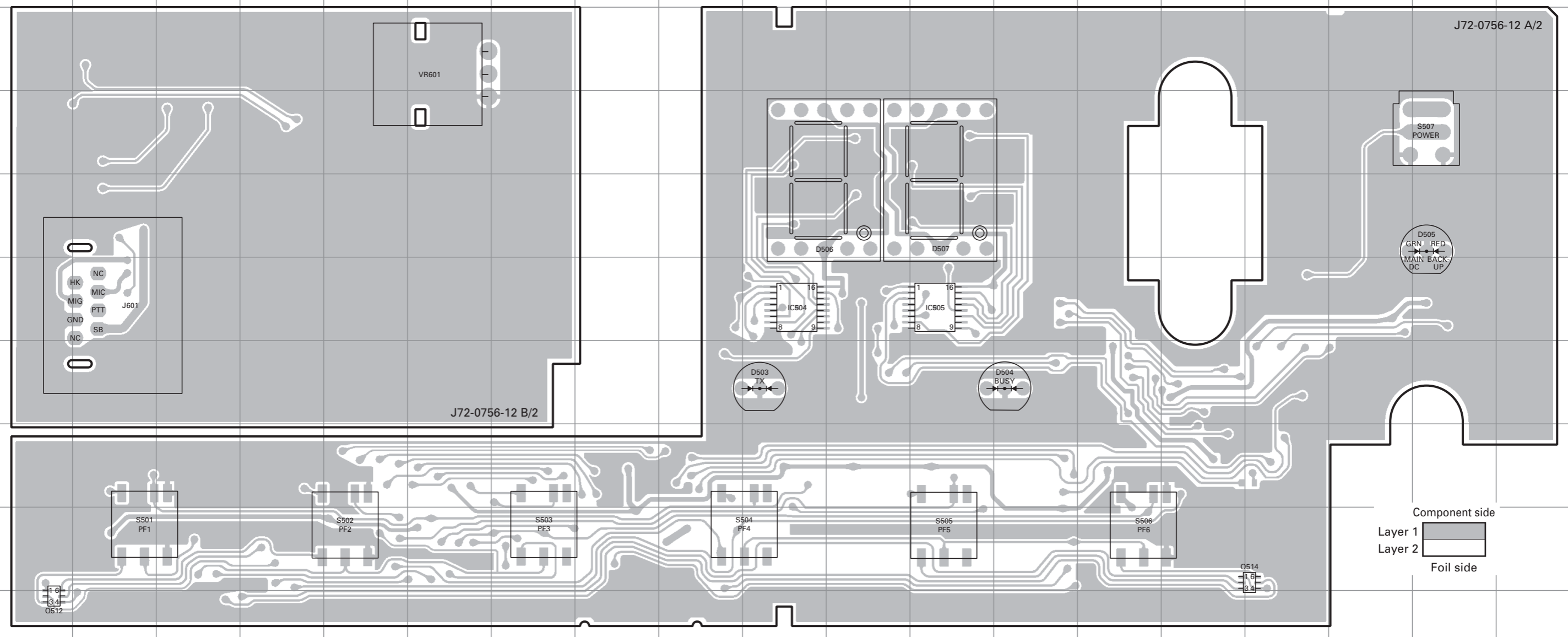
Ref. No.	Address
IC504	6J
IC505	6L
Q512	10A
Q514	9P
D503	7J
D504	7M
D505	5R
D506	5J
D507	5L

TKR-850 PC BOARD / PC板

PC BOARD / PC板 TKR-850

DISPLAY UNIT (X54-3330-21) Component side view (J72-0756-12)

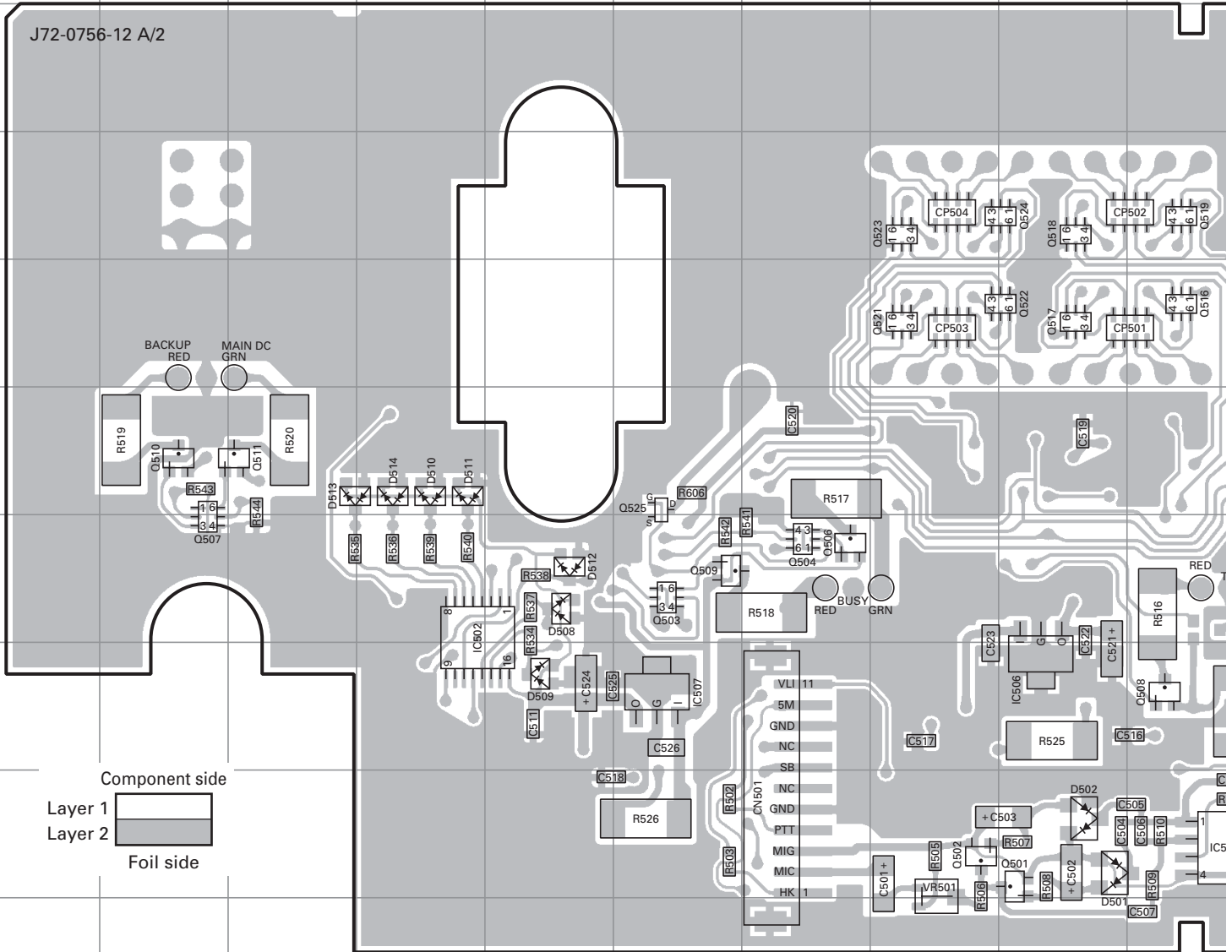
DISPLAY UNIT (X54-3330-21) Component side view (J72-0756-12)



Ref. No.	Address
IC504	6J
IC505	6L
Q512	10A
Q514	9P
D503	7J
D504	7M
D505	5R
D506	5J
D507	5L

TKR-850 PC BOARD / PC板

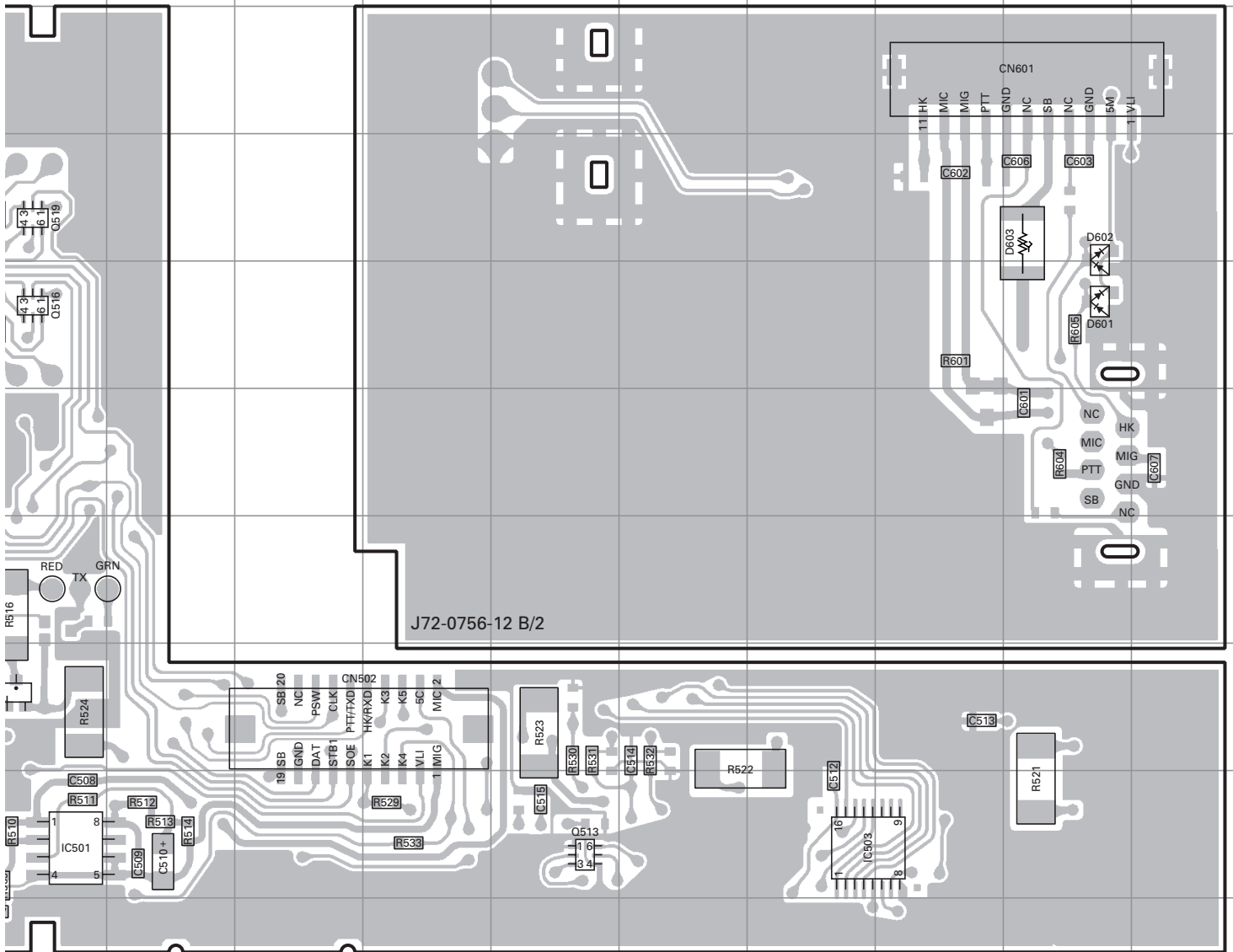
DISPLAY UNIT (X54-3330-21) Foil side view (J72-0756-12)



Ref. No.	Address	Ref. No.	Address	Ref. No.	Address	Ref. No.	Address
IC501	9J	Q507	7B	Q521	5H	D511	6D
IC502	7D	Q508	8J	Q522	5I	D512	7E
IC503	9P	Q509	7F	Q523	4H	D513	6C
IC506	8I	Q510	6B	Q524	4I	D514	6D
IC507	8F	Q511	6C	Q525	6F	D601	5R
Q501	9I	Q513	9N	D501	9I	D602	4R
Q502	9H	Q516	5J	D502	9I	D603	4R
Q503	7F	Q517	5I	D508	7E		
Q504	7G	Q518	4I	D509	8E		
Q506	7G	Q519	4J	D510	6D		

PC BOARD / PC板 TKR-850

DISPLAY UNIT (X54-3330-21) Foil side view (J72-0756-12)



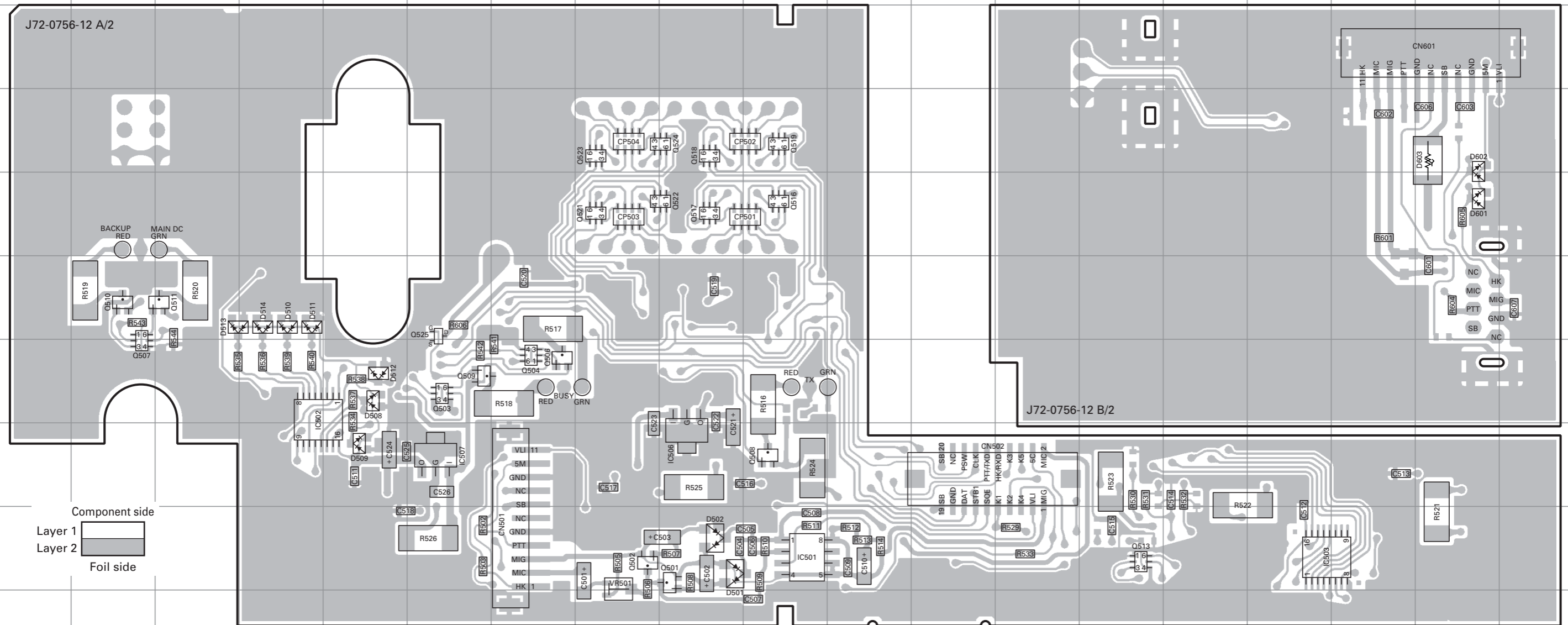
J72-0756-12 B/2

TKR-850 PC BOARD / PC板

PC BOARD / PC板 TKR-850

DISPLAY UNIT (X54-3330-21) Foil side view (J72-0756-12)

DISPLAY UNIT (X54-3330-21) Foil side view (J72-0756-12)



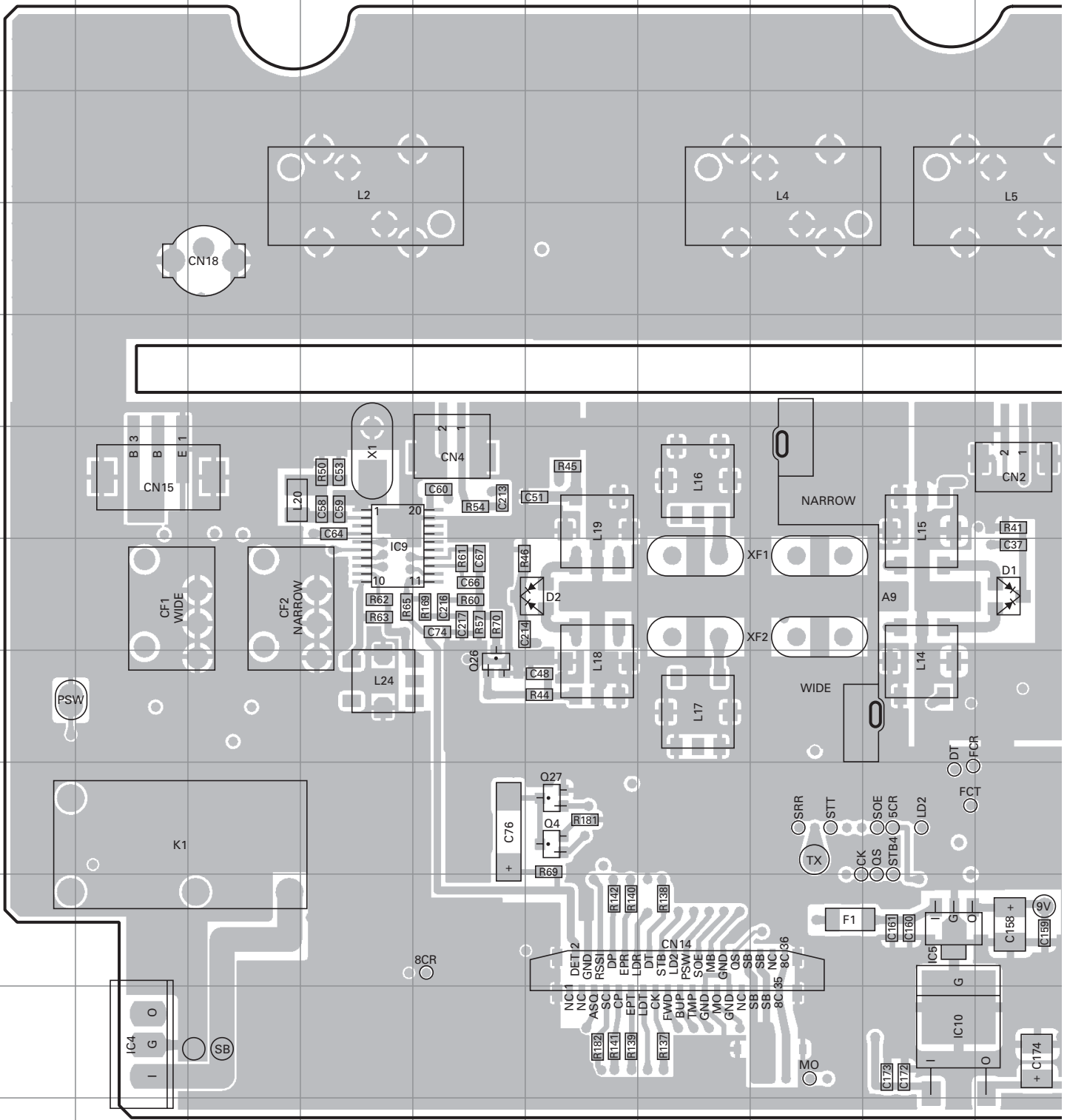
Component side
 Layer 1
 Layer 2
 Foil side

Ref. No.	Address	Ref. No.	Address	Ref. No.	Address	Ref. No.	Address
IC501	9J	Q507	7B	Q521	5H	D511	6D
IC502	7D	Q508	8J	Q522	5I	D512	7E
IC503	9P	Q509	7F	Q523	4H	D513	6C
IC506	8I	Q510	6B	Q524	4I	D514	6D
IC507	8F	Q511	6C	Q525	6F	D601	5R
Q501	9I	Q513	9N	D501	9I	D602	4R
Q502	9H	Q516	5J	D502	9I	D603	4R
Q503	7F	Q517	5I	D508	7E		
Q504	7G	Q518	4I	D509	8E		
Q506	7G	Q519	4J	D510	6D		

TKR-850 PC BOARD / PC板

TX-RX UNIT (X57-696X-XX) (A/2) 0-11 : C 0-13 : C3 3-01 : C6

Component side view (J72-0924-19 A/2)

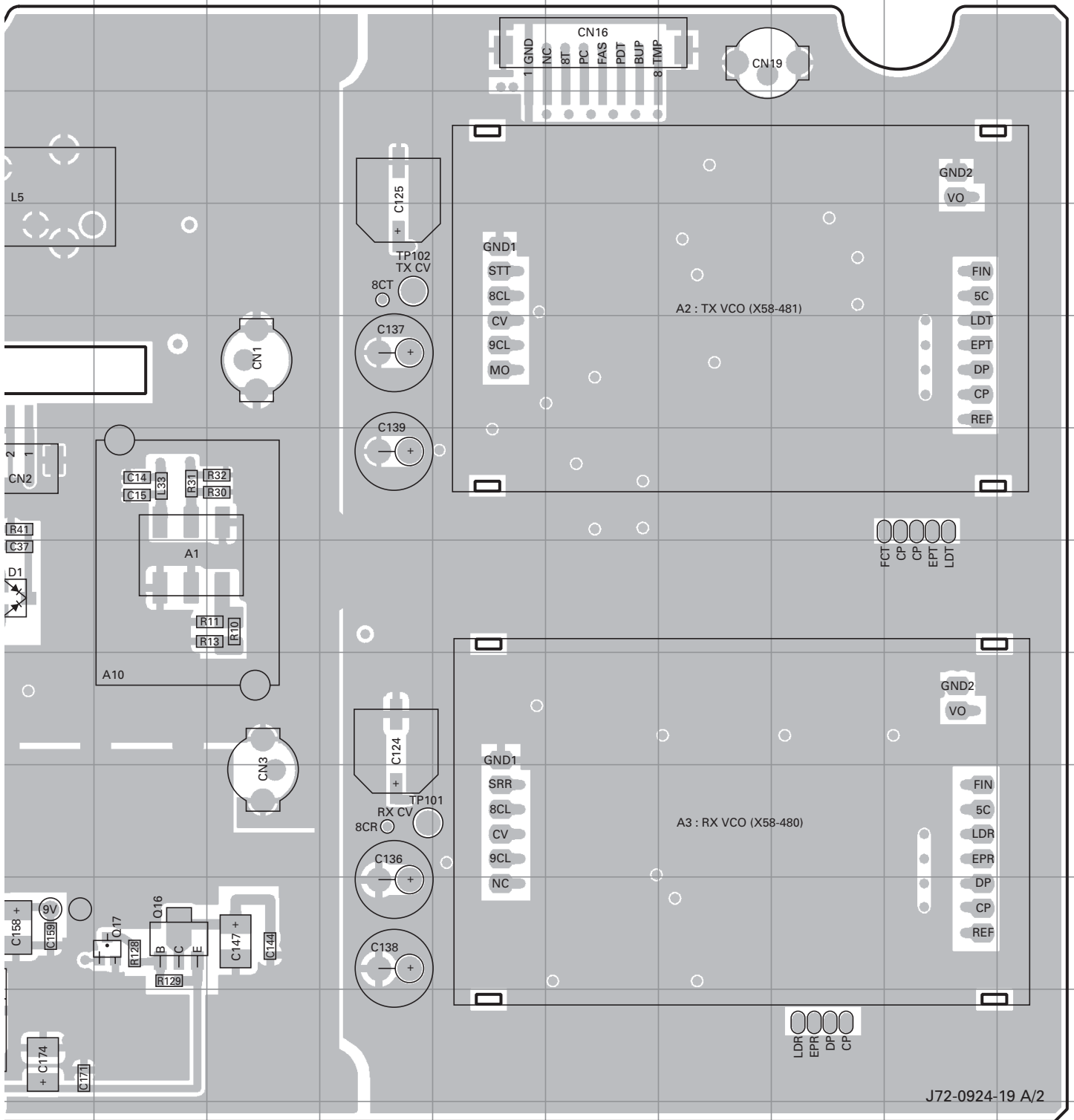


Ref. No.	Address	Ref. No.	Address	Ref. No.	Address
IC4	11B	Q4	9F	Q27	9F
IC5	10I	Q16	10K	D1	7J
IC9	7D	Q17	10K	D2	7F
IC10	11I	Q26	8E		

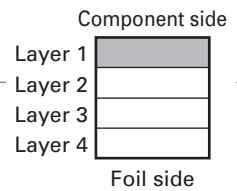
PC BOARD / PC板 TKR-850

TX-RX UNIT (X57-696X-XX) (A/2) 0-11 : C 0-13 : C3 3-01 : C6

Component side view (J72-0924-19 A/2)



J72-0924-19 A/2

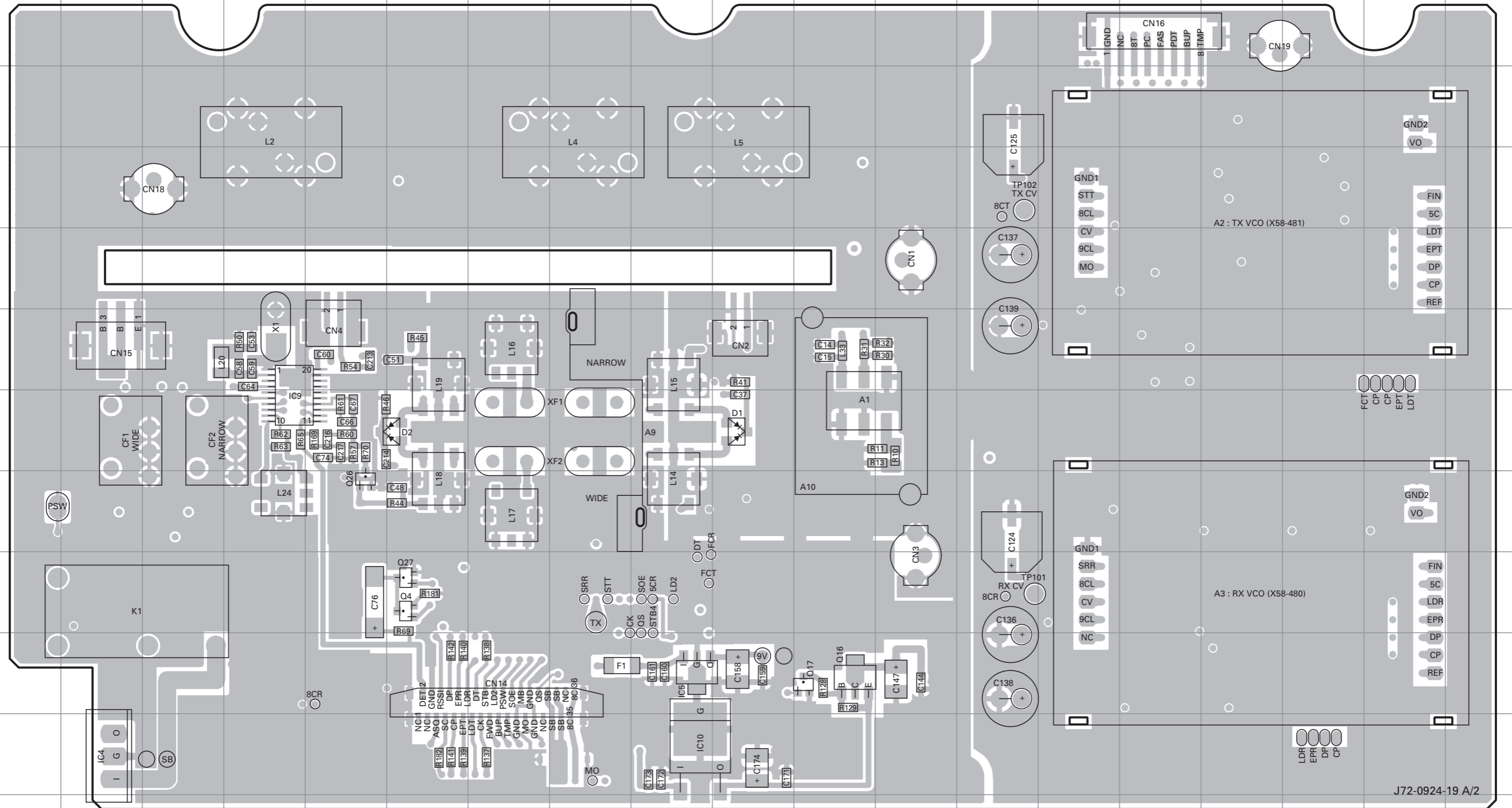


TKR-850 PC BOARD / PC板

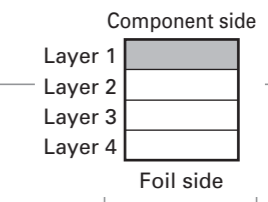
TX-RX UNIT (X57-696X-XX) (A/2) 0-11 : C 0-13 : C3 3-01 : C6
Component side view (J72-0924-19 A/2)

PC BOARD / PC板 TKR-850

TX-RX UNIT (X57-696X-XX) (A/2) 0-11 : C 0-13 : C3 3-01 : C6
Component side view (J72-0924-19 A/2)



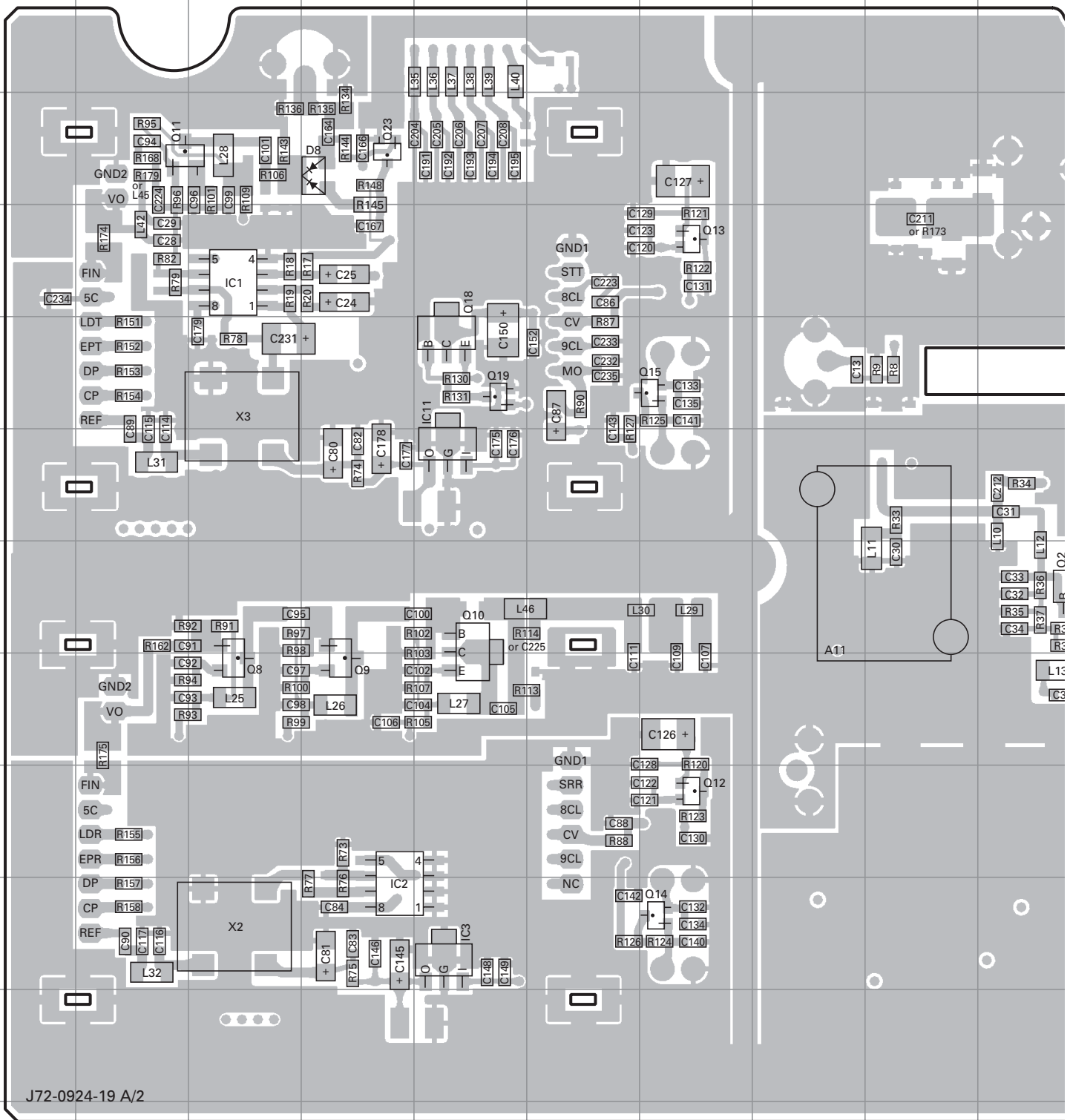
Ref. No.	Address	Ref. No.	Address	Ref. No.	Address
IC4	11B	Q4	9F	Q27	9F
IC5	10I	Q16	10K	D1	7J
IC9	7D	Q17	10K	D2	7F
IC10	11I	Q26	8E		



TKR-850 PC BOARD / PC板

TX-RX UNIT (X57-696X-XX) (A/2) 0-11 : C 0-13 : C3 3-01 : C6

Foil side view (J72-0924-19 A/2)



J72-0924-19 A/2

Ref. No.	Address	Ref. No.	Address	Ref. No.	Address	Ref. No.	Address	Ref. No.	Address	Ref. No.	Address
IC1	4C	Q1	3N	Q8	8C	Q14	10G	Q25	9R	D11	10N
IC2	10D	Q2	7J	Q9	8D	Q15	5G	D3	7Q	D12	9Q
IC3	10E	Q3	7O	Q10	7E	Q18	5E	D4	8Q	D13	11N
IC6	9K	Q5	9N	Q11	3B	Q19	5E	D5	11O		
IC7	9L	Q6	9M	Q12	9G	Q23	3D	D7	9S		
IC11	6E	Q7	10O	Q13	4G	Q24	9R	D8	3D		

TKR-850 PC BOARD / PC板

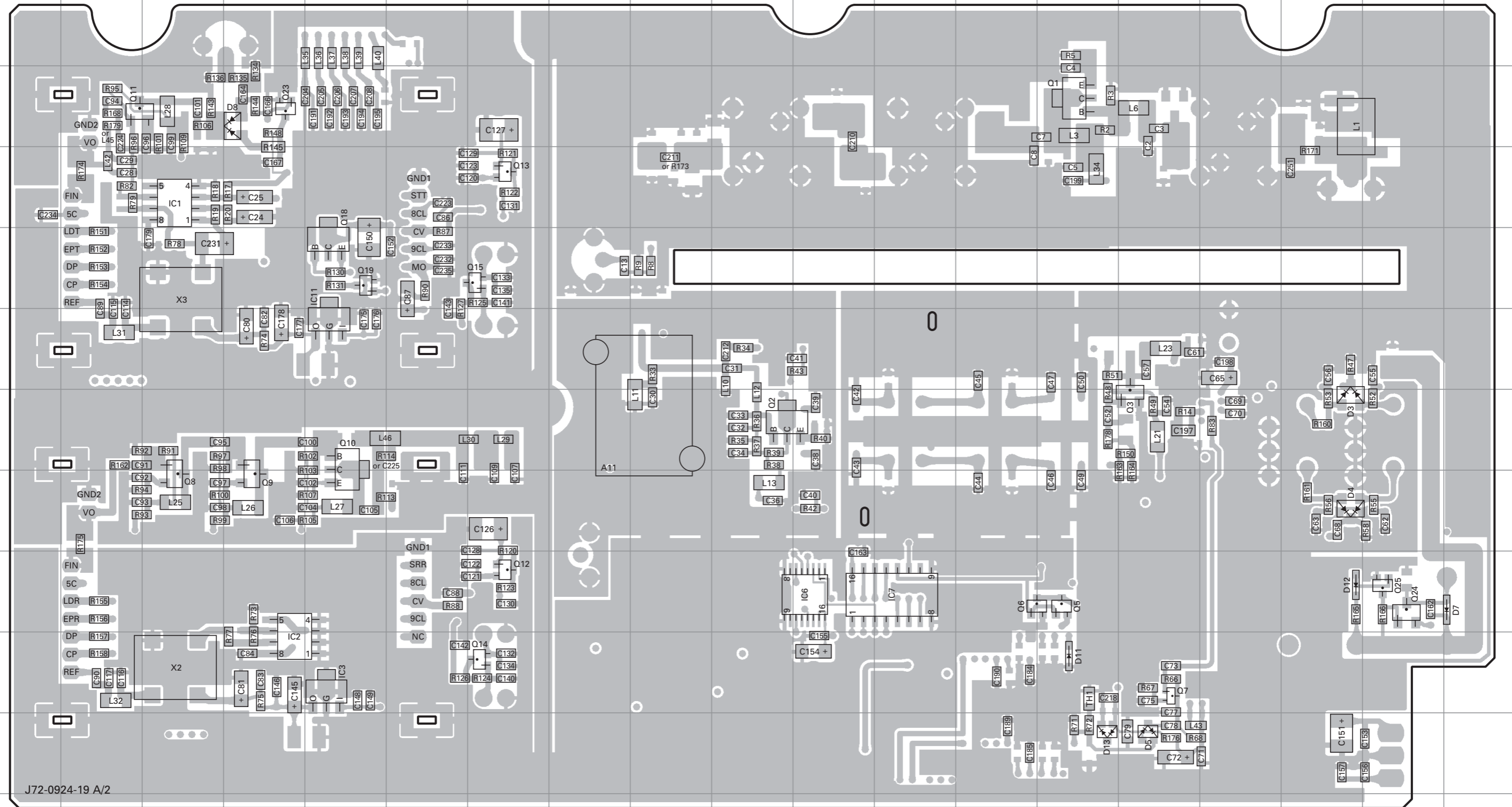
TX-RX UNIT (X57-696X-XX) (A/2) 0-11 : C 0-13 : C3 3-01 : C6

Foil side view (J72-0924-19 A/2)

PC BOARD / PC板 TKR-850

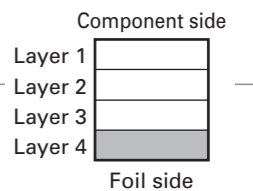
TX-RX UNIT (X57-696X-XX) (A/2) 0-11 : C 0-13 : C3 3-01 : C6

Foil side view (J72-0924-19 A/2)



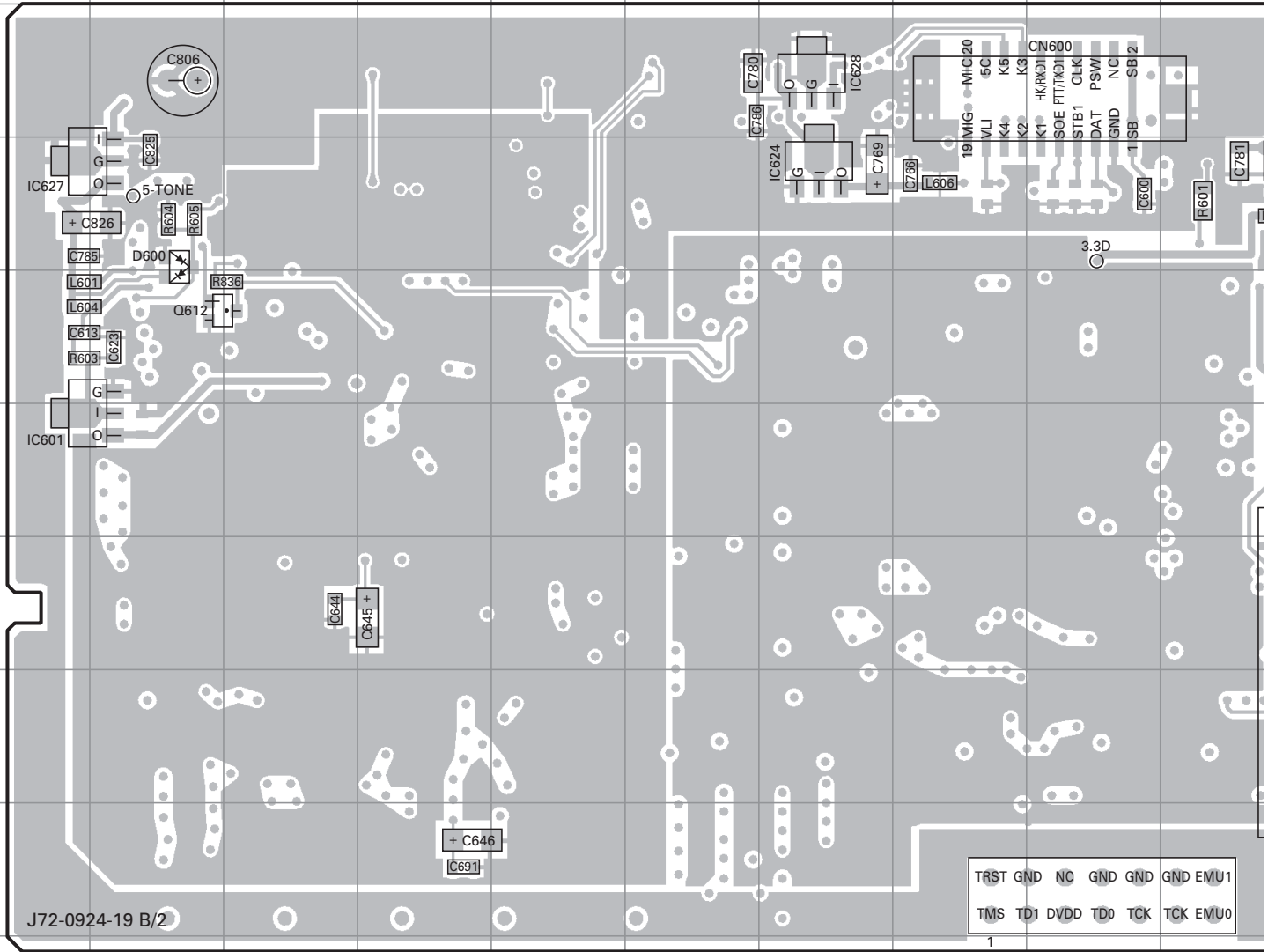
J72-0924-19 A/2

Ref. No.	Address	Ref. No.	Address	Ref. No.	Address	Ref. No.	Address	Ref. No.	Address	Ref. No.	Address
IC1	4C	Q1	3N	Q8	8C	Q14	10G	Q25	9R	D11	10N
IC2	10D	Q2	7J	Q9	8D	Q15	5G	D3	7Q	D12	9Q
IC3	10E	Q3	7O	Q10	7E	Q18	5E	D4	8Q	D13	11N
IC6	9K	Q5	9N	Q11	3B	Q19	5E	D5	11O		
IC7	9L	Q6	9M	Q12	9G	Q23	3D	D7	9S		
IC11	6E	Q7	10O	Q13	4G	Q24	9R	D8	3D		



TKR-850 PC BOARD / PC板

TX-RX UNIT (X57-696X-XX) (B/2) 0-11 : C 0-13 : C3 3-01 : C6
 Component side view (J72-0924-19 B/2)



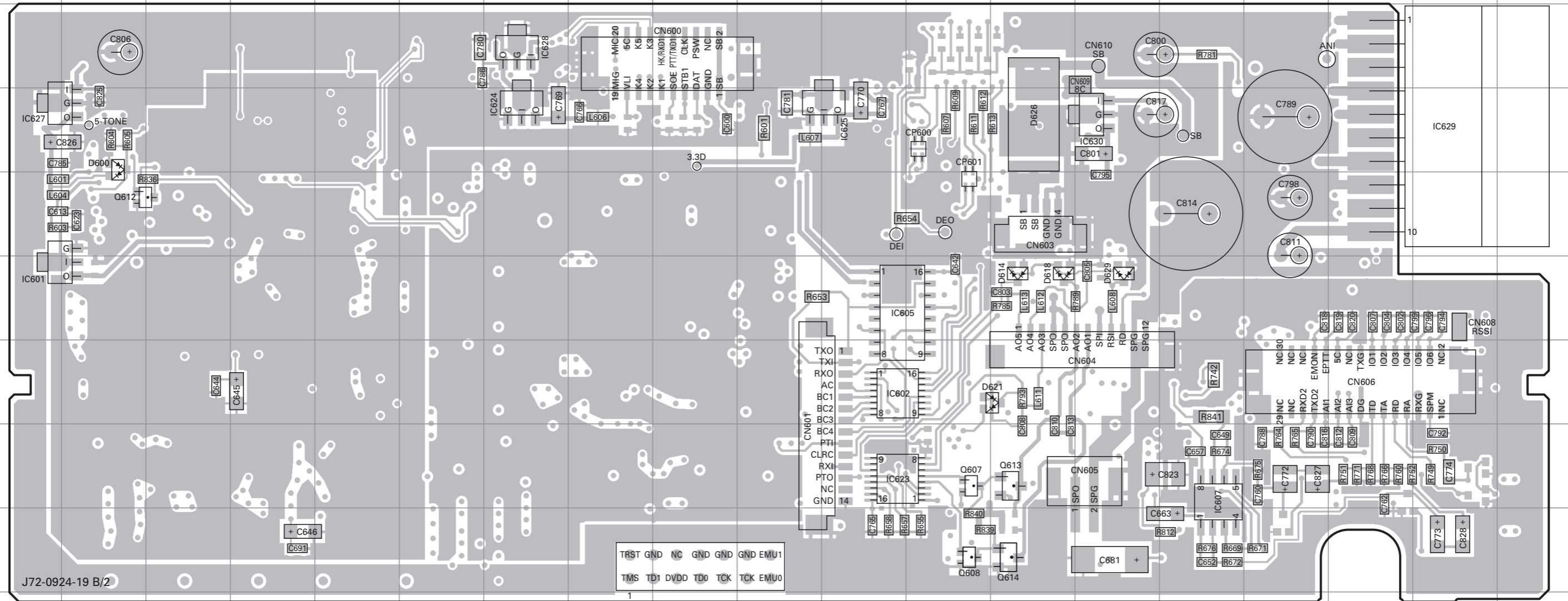
Ref. No.	Address	Ref. No.	Address	Ref. No.	Address
IC601	6A	IC628	3G	D600	4B
IC602	7K	IC629	4R	D614	6M
IC605	6K	IC630	4N	D618	6M
IC607	8O	Q607	8L	D621	7M
IC623	8K	Q608	9L	D626	4M
IC624	4G	Q612	5B	D629	6N
IC625	4K	Q613	8M		
IC627	4A	Q614	9M		

TKR-850 PC BOARD / PC板

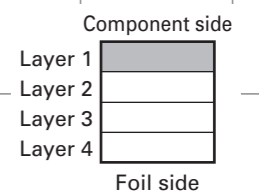
PC BOARD / PC板 TKR-850

TX-RX UNIT (X57-696X-XX) (B/2) 0-11 : C 0-13 : C3 3-01 : C6
Component side view (J72-0924-19 B/2)

TX-RX UNIT (X57-696X-XX) (B/2) 0-11 : C 0-13 : C3 3-01 : C6
Component side view (J72-0924-19 B/2)

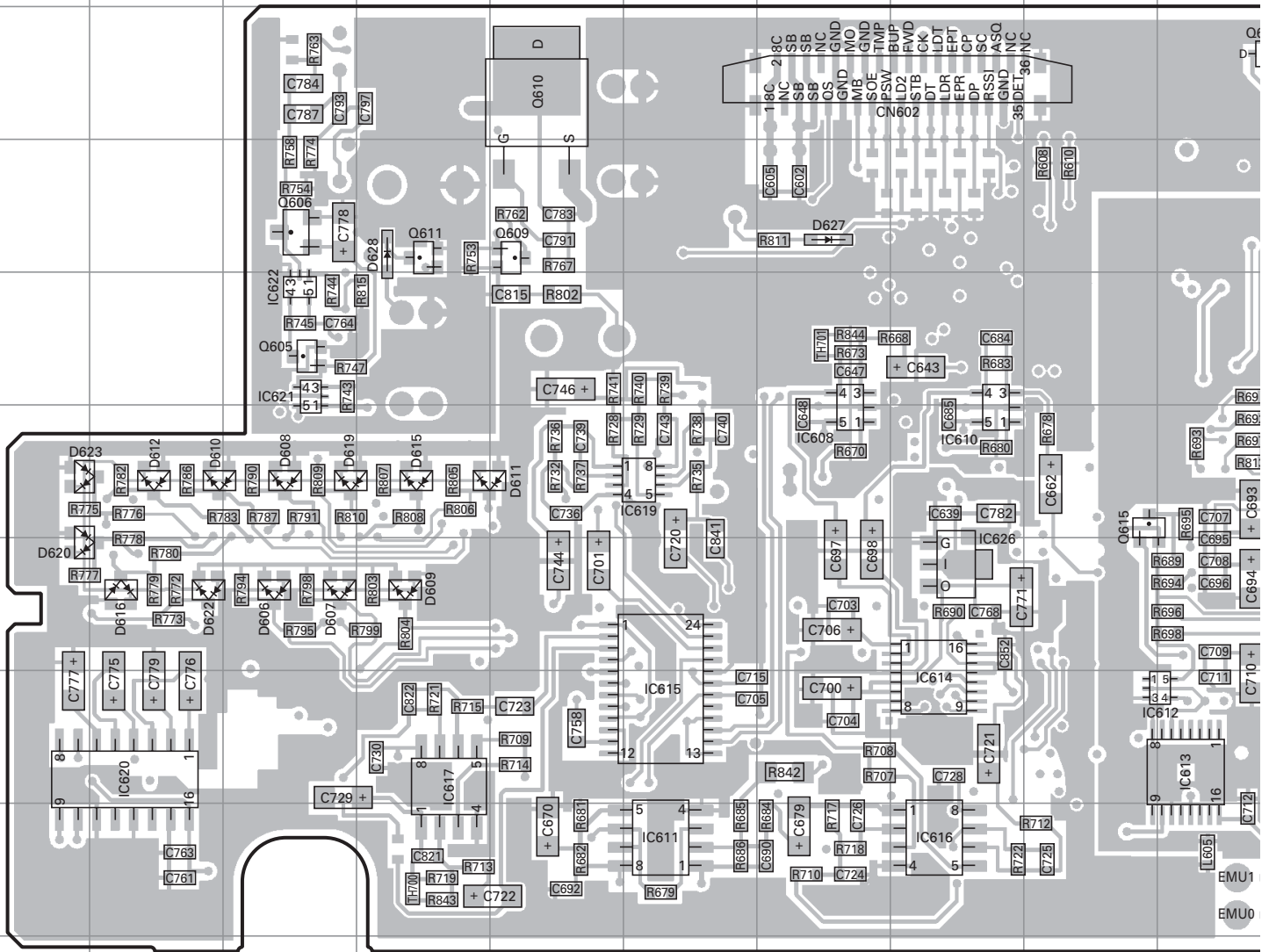


Ref. No.	Address	Ref. No.	Address	Ref. No.	Address
IC601	6A	IC628	3G	D600	4B
IC602	7K	IC629	4R	D614	6M
IC605	6K	IC630	4N	D618	6M
IC607	8O	Q607	8L	D621	7M
IC623	8K	Q608	9L	D626	4M
IC624	4G	Q612	5B	D629	6N
IC625	4K	Q613	8M		
IC627	4A	Q614	9M		



TKR-850 PC BOARD / PC板

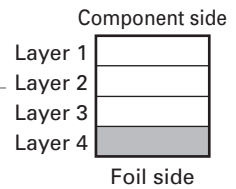
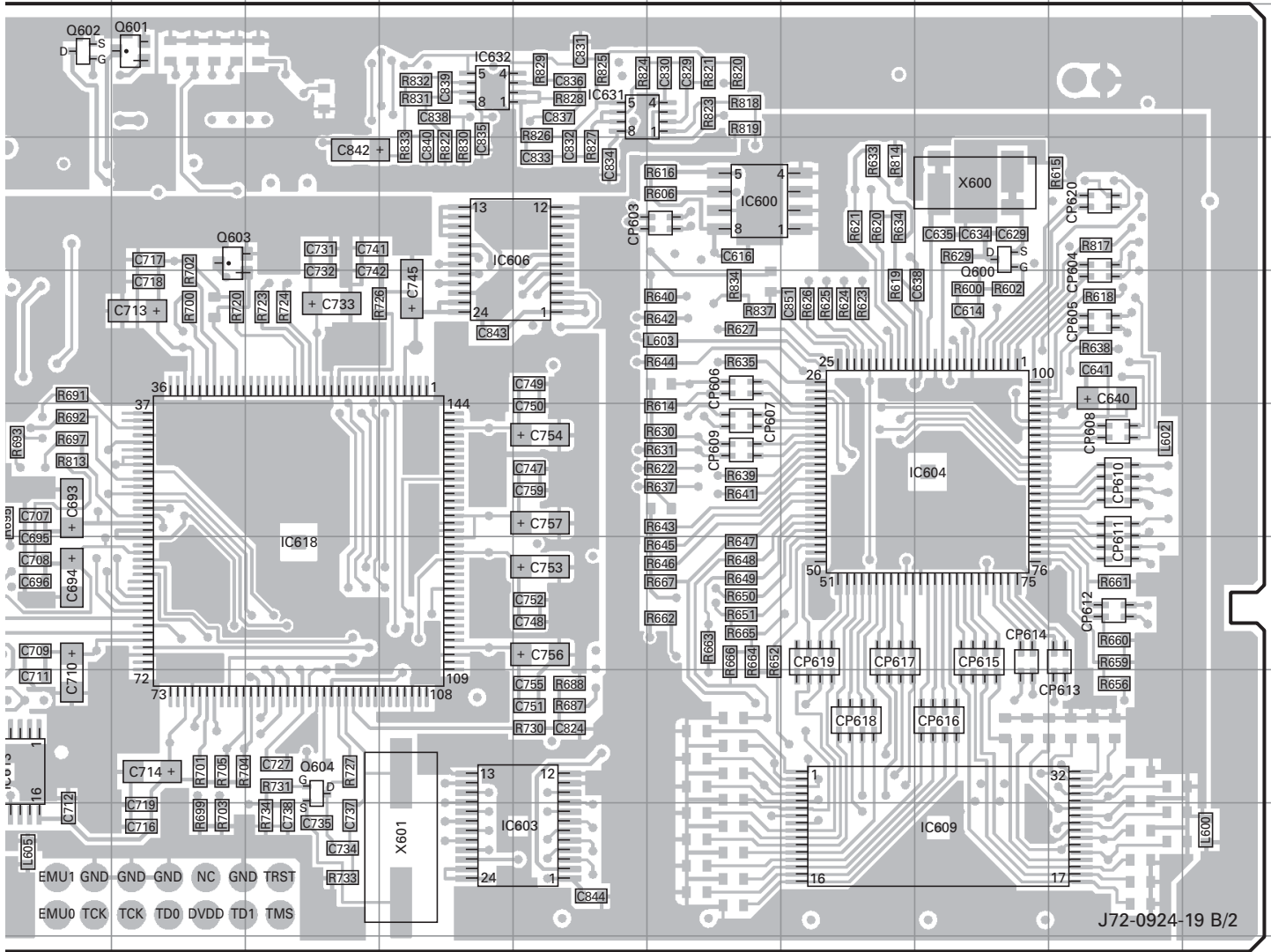
TX-RX UNIT (X57-696X-XX) (B/2) 0-11 : C 0-13 : C3 3-01 : C6
Foil side view (J72-0924-19 B/2)



Ref. No.	Address	Ref. No.	Address	Ref. No.	Address	Ref. No.	Address	Ref. No.	Address	Ref. No.	Address
IC600	4O	IC612	8J	IC620	8B	Q602	3J	Q615	6I	D615	6D
IC603	9N	IC613	8J	IC621	5C	Q603	4K	D606	7C	D616	7B
IC604	6Q	IC614	8H	IC622	5C	Q604	8L	D607	7C	D619	6C
IC606	4M	IC615	8F	IC626	7H	Q605	5C	D608	6C	D620	7A
IC608	6G	IC616	9H	IC631	3N	Q606	4C	D609	7D	D622	7B
IC609	9Q	IC617	8D	IC632	3M	Q609	4E	D610	6B	D623	6A
IC610	6H	IC618	7L	Q600	4Q	Q610	3E	D611	6E	D627	4G
IC611	9F	IC619	6F	Q601	3K	Q611	4D	D612	6B	D628	4D

PC BOARD / PC板 TKR-850

TX-RX UNIT (X57-696X-XX) (B/2) 0-11 : C 0-13 : C3 3-01 : C6
Foil side view (J72-0924-19 B/2)

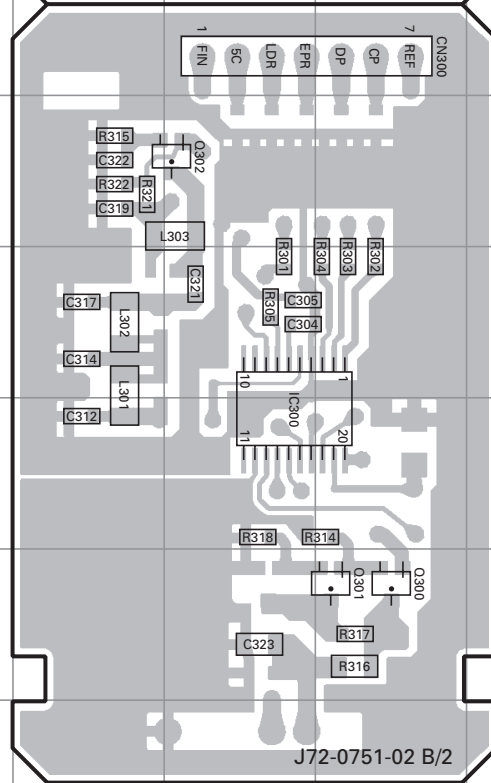
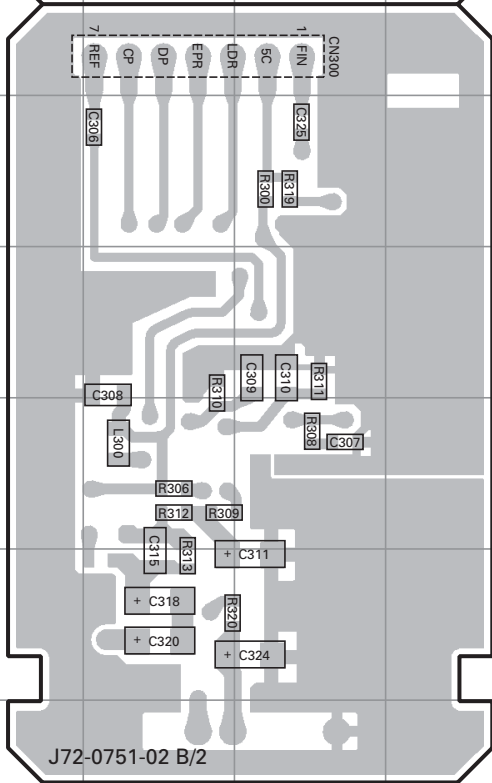
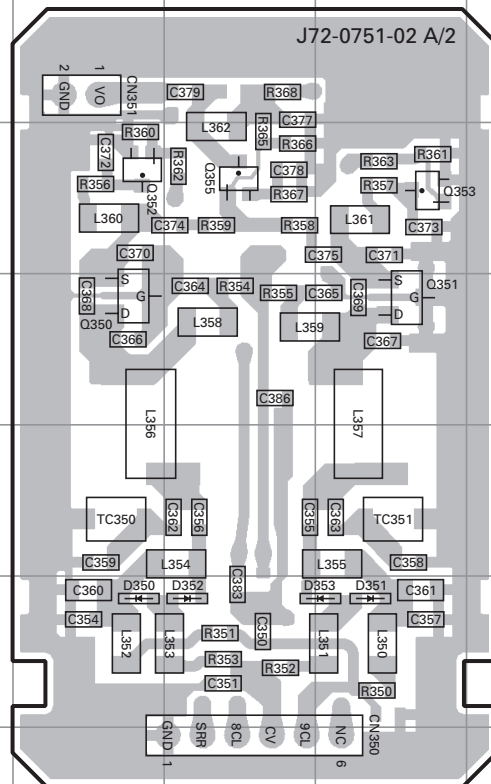
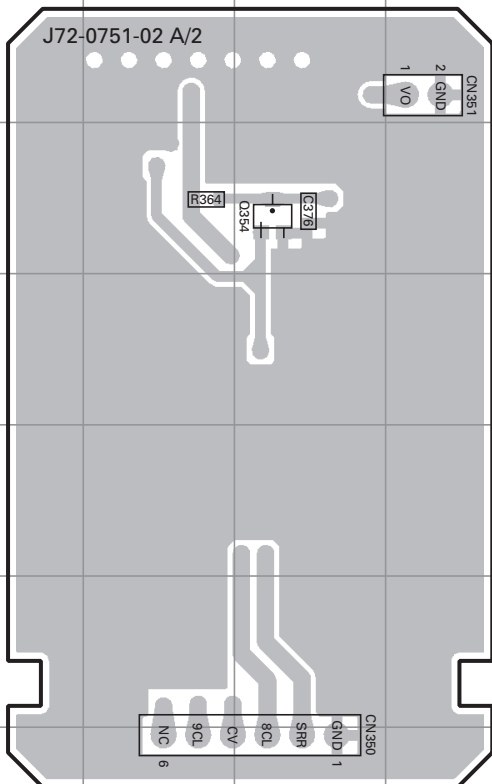


TKR-850 PC BOARD / PC板

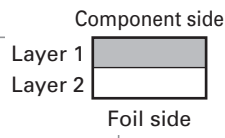
RX VCO UNIT (X58-480X-XX) 0-10 : C 0-12 : C3 3-01 : C6 (J72-0751-02)

Component side view

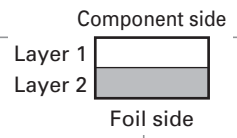
Foil side view



Ref. No.	Address
Q354	3C

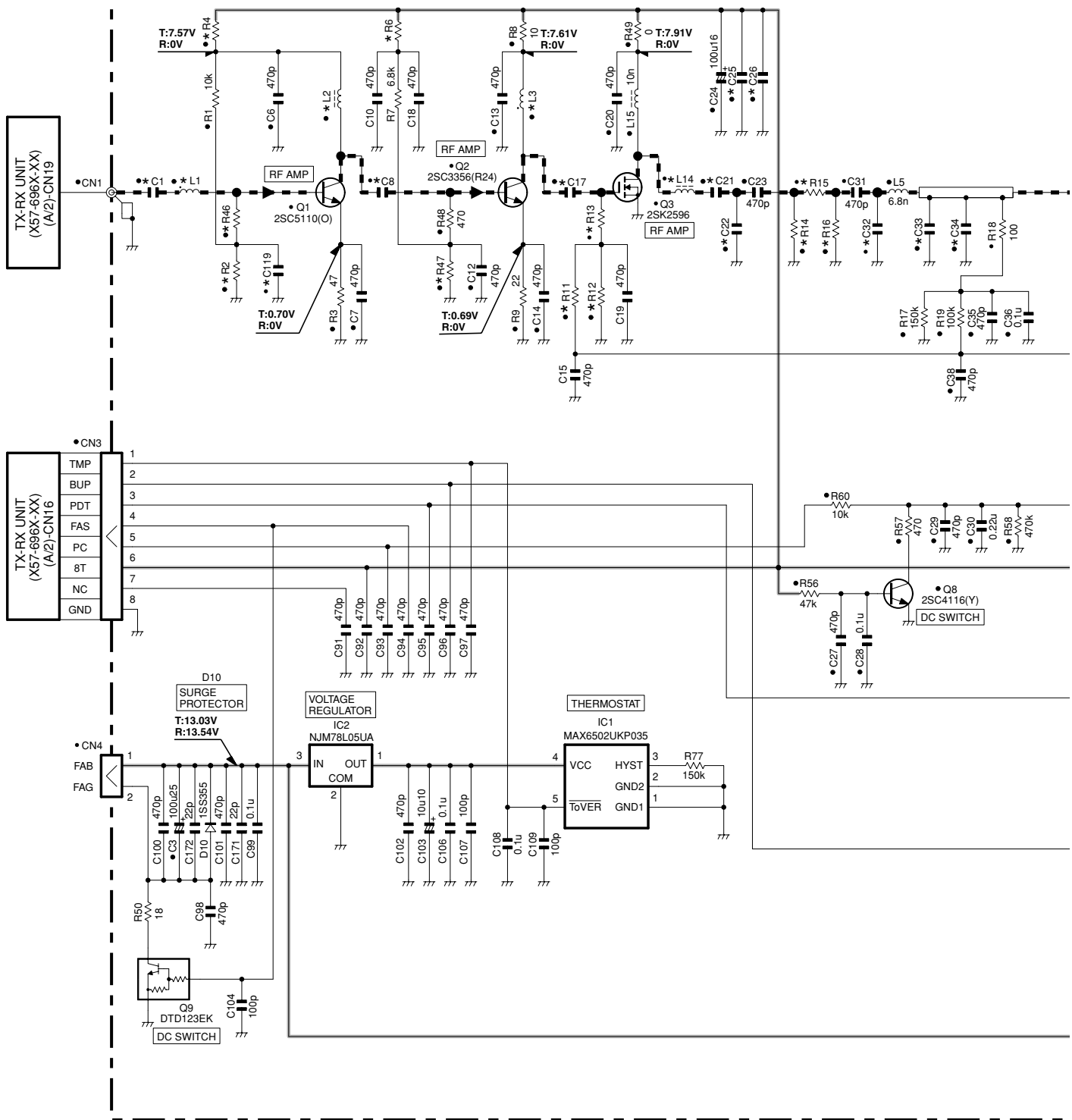


Ref. No.	Address	Ref. No.	Address	Ref. No.	Address
IC300	10G	Q351	4H	D51	6H
Q300	11H	Q352	3F	D52	6G
Q301	11H	Q353	3H	D53	6H
Q302	8G	Q355	3G		
Q350	4F	D350	6F		



TKR-850 SCHEMATIC DIAGRAM / 原理图

FINAL UNIT (X45-374X-XX) (A/2)

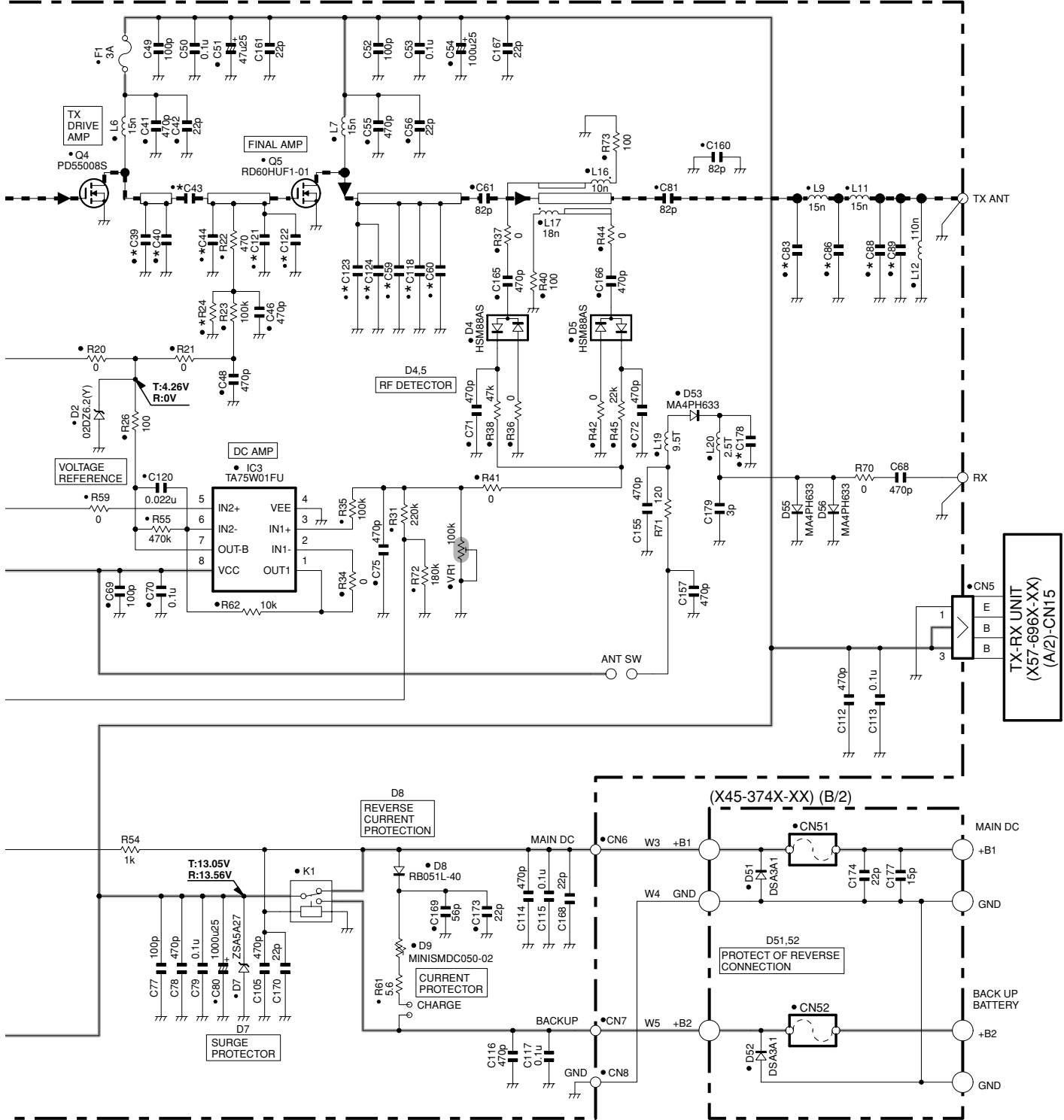


X45-374X-XX	L1	L2	L3	L14	R2	R4	R6	R11	R12	R13	R14	R15	R16	R46	R47	C1	C8	C17	C21	C22	C25	C26	C32	C33	C34	C119	
0-10	C	10n	10n	18n	15n	2.2k	22	47	100k	18k	47	1k	5.6	1k	470	2.2k	470p	8p	5p	12p	6p	NO	470p	8p	27p	27p	470p
0-12	C3	3.9n	27n	8.2n	10n	4.7k	10	10	33k	15k	22	270	18	270	0	3.3k	10p	56p	22p	12p	NO	100p	8p	39p	39p	NO	
3-01	C6	3.9n	27n	8.2n	10n	4.7k	10	10	33k	15k	22	180	33	180	0	3.3k	10p	10p	56p	22p	12p	0.1u	100p	10p	47p	47p	NO

SCHEMATIC DIAGRAM / 原理图 TKR-850

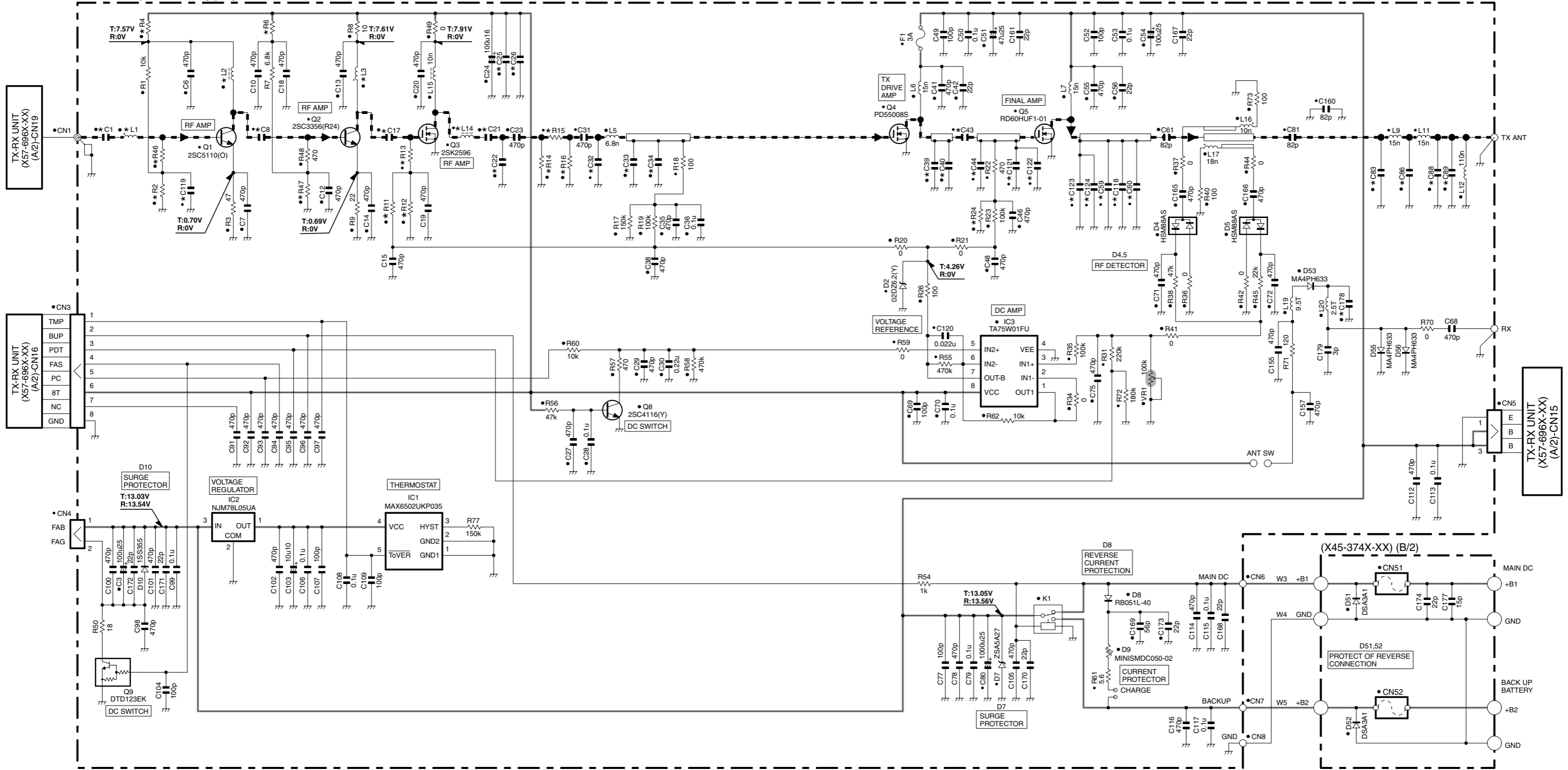
Note : The components marked with a dot (•) are parts of layer 1.

FINAL UNIT (X45-374X-XX) (A/2)



X45-3740-XX	C39	C40	C43	C44	C59	C60	C83	C86	C88	C89	C118	C121	C122	C123	C124	C178	
0-10	C	12p	22p	22p	6p	10p	NO	6p	10p	NO	5p	4p	15p	15p	22p	22p	3p
0-12	C3	18p	NO	22p	10p	12p	8p	7p	12p	6p	NO	NO	18p	18p	27p	27p	3p
3-01	C6	22p	NO	39p	10p	27p	10p	10p	18p	NO	10p	NO	22p	22p	27p	27p	5p

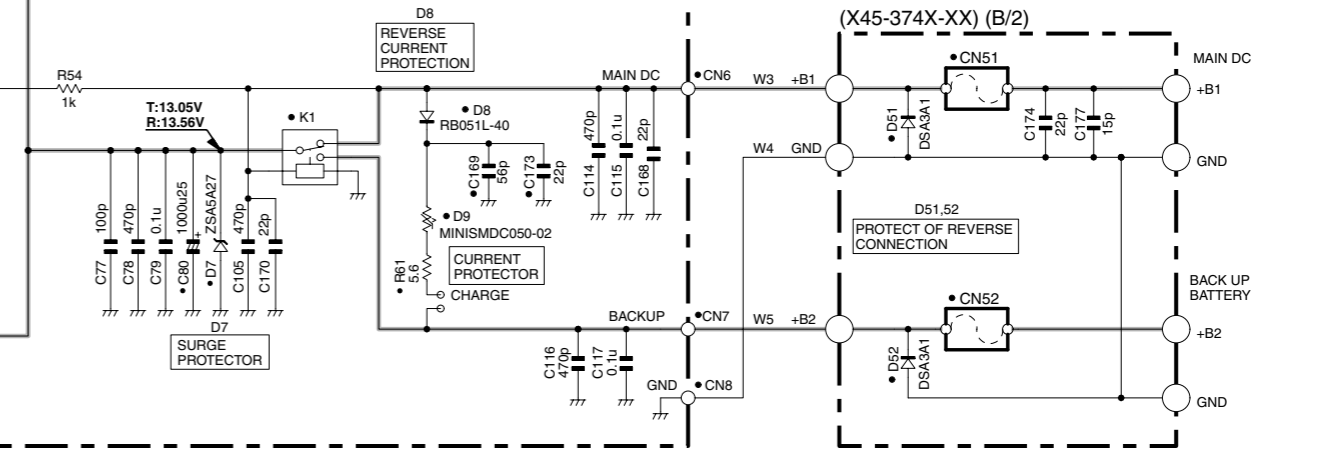
FINAL UNIT (X45-374X-XX) (A/2)



X45-374X-XX	L1	L2	L3	L14	R2	R4	R6	R11	R12	R13	R14	R15	R16	R46	R47	C1	C8	C17	C21	C22	C25	C26	C32	C33	C34	C119
0-10	C	10n	10n	18n	15n	2.2k	22	47	100k	18k	47	1k	5.6	1k	470	2.2k	470p	8p	5p	12p	6p	NO	470p	8p	27p	470p
0-12	C3	3.9n	27n	8.2n	10n	10	10	33k	15k	22	270	18	270	0	3.3k	10p	10p	56p	22p	12p	NO	100p	8p	39p	39p	NO
3-01	C6	3.9n	27n	8.2n	10n	10	10	33k	15k	22	180	33	180	0	3.3k	10p	10p	56p	22p	12p	0.1u	100p	10p	47p	47p	NO

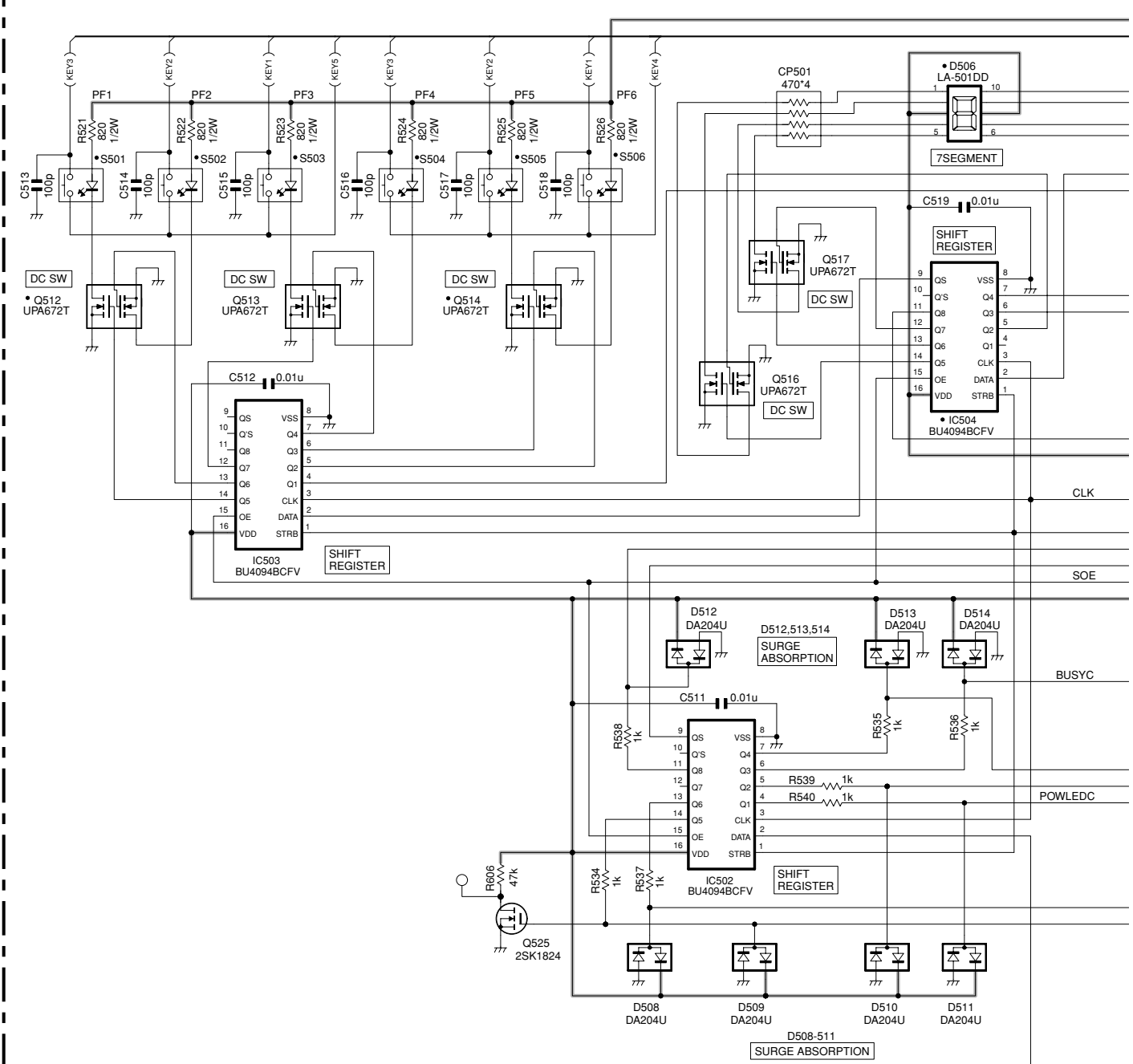
X45-3740-XX	C39	C40	C43	C44	C59	C60	C83	C86	C88	C89	C118	C121	C122	C123	C124	C178
0-10	C	12p	22p	22p	6p	10p	NO	6p	10p	NO	5p	4p	15p	15p	22p	22p
0-12	C3	18p	NO	22p	10p	12p	8p	7p	12p	6p	NO	NO	18p	18p	27p	27p
3-01	C6	22p	NO	39p	10p	27p	10p	10p	18p	NO	10p	NO	22p	22p	27p	27p

(X45-374X-XX) (B/2)

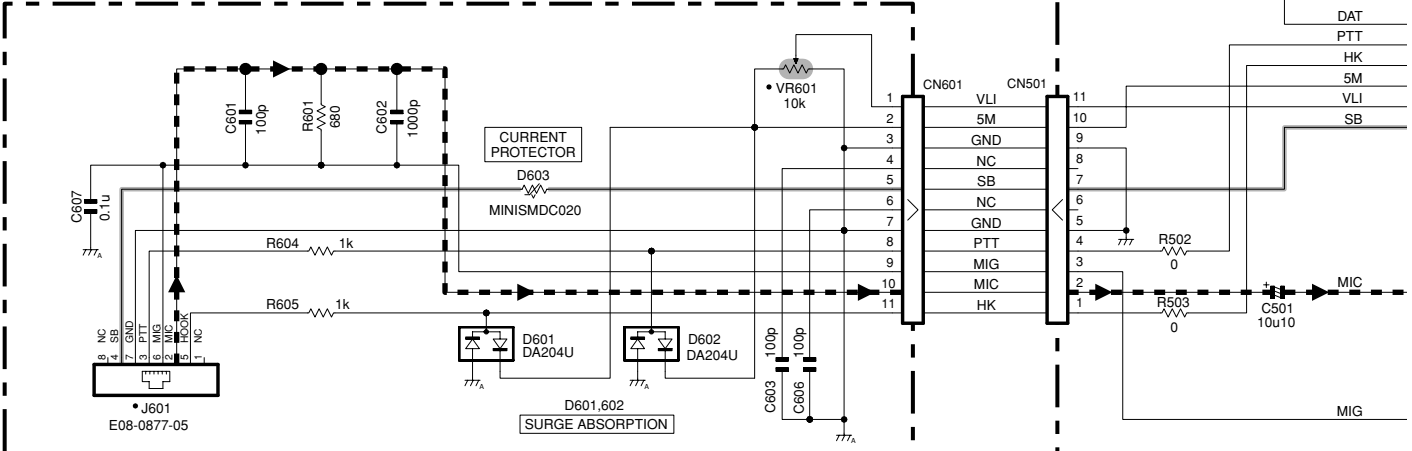


TKR-850 SCHEMATIC DIAGRAM / 原理图

DISPLAY UNIT (X54-3330-21) (A/2)

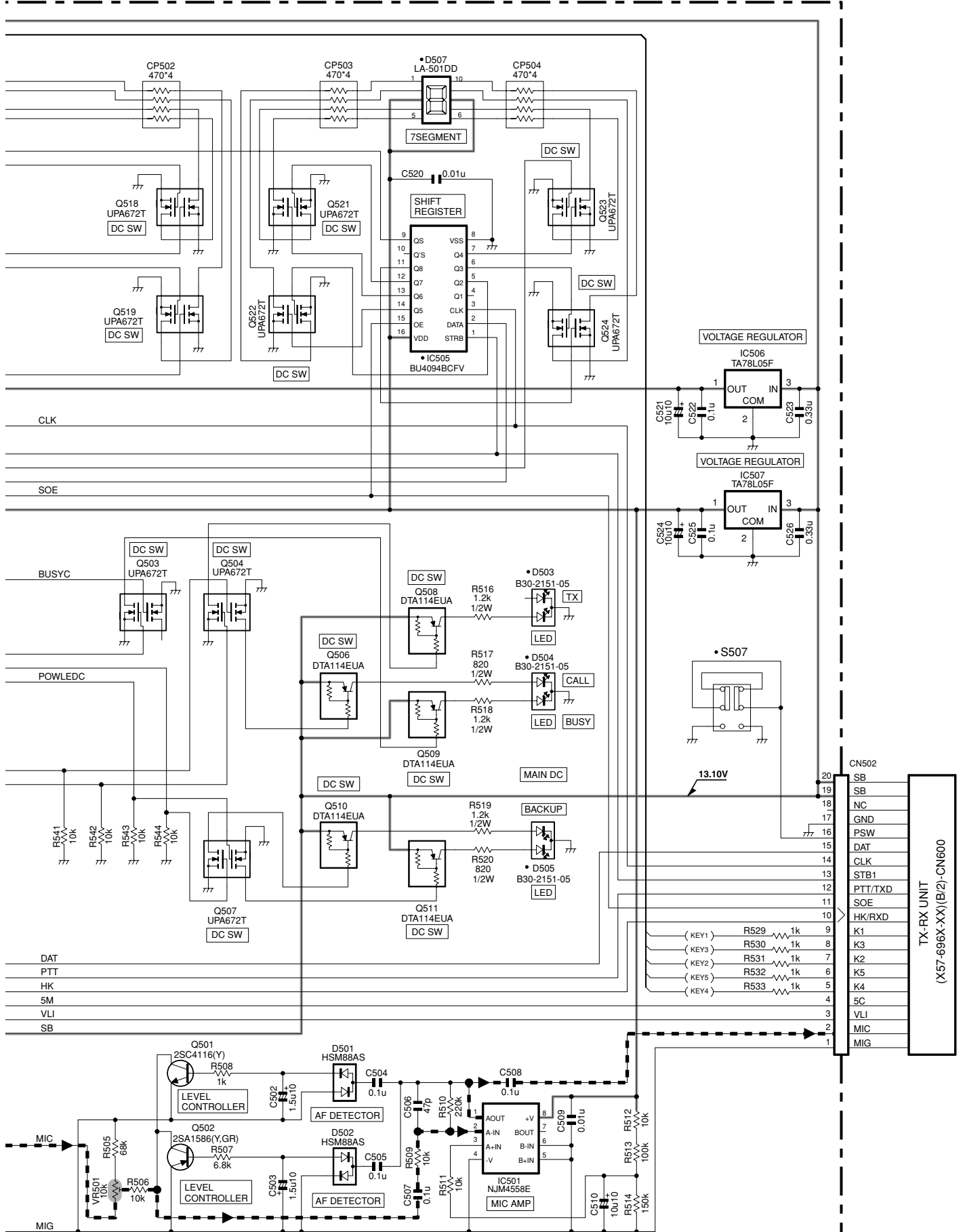


DISPLAY UNIT (X54-3330-21) (B/2)



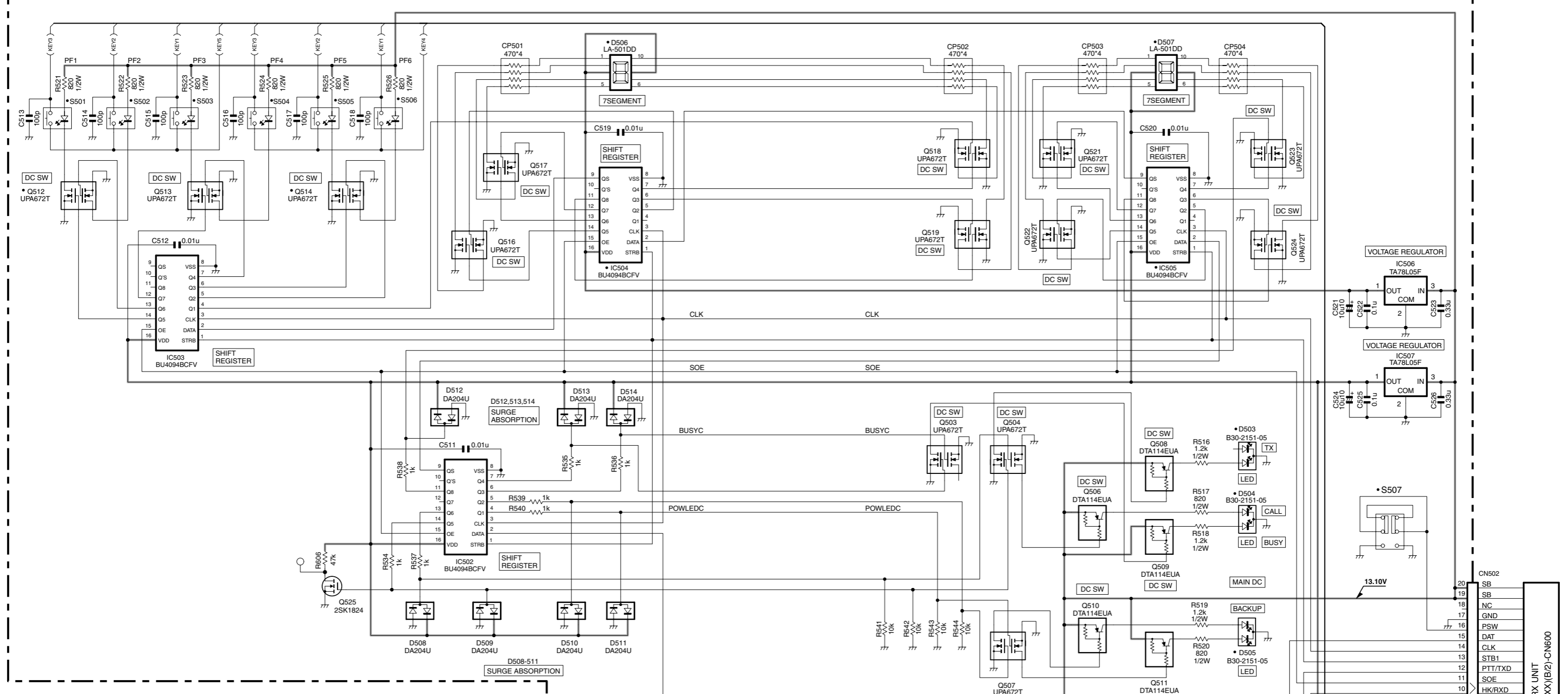
SCHEMATIC DIAGRAM / 原理图 TKR-850

DISPLAY UNIT (X54-3330-21) (A/2)

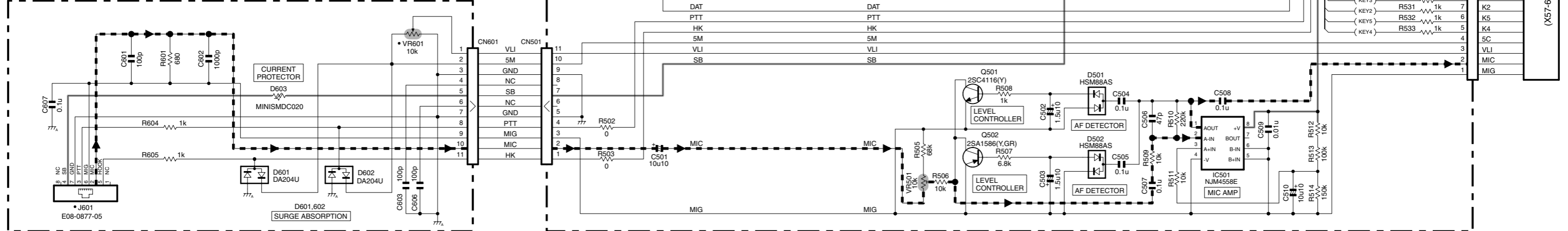


Note : The components marked with a dot (•) are parts of layer 1.

DISPLAY UNIT (X54-3330-21) (A/2)

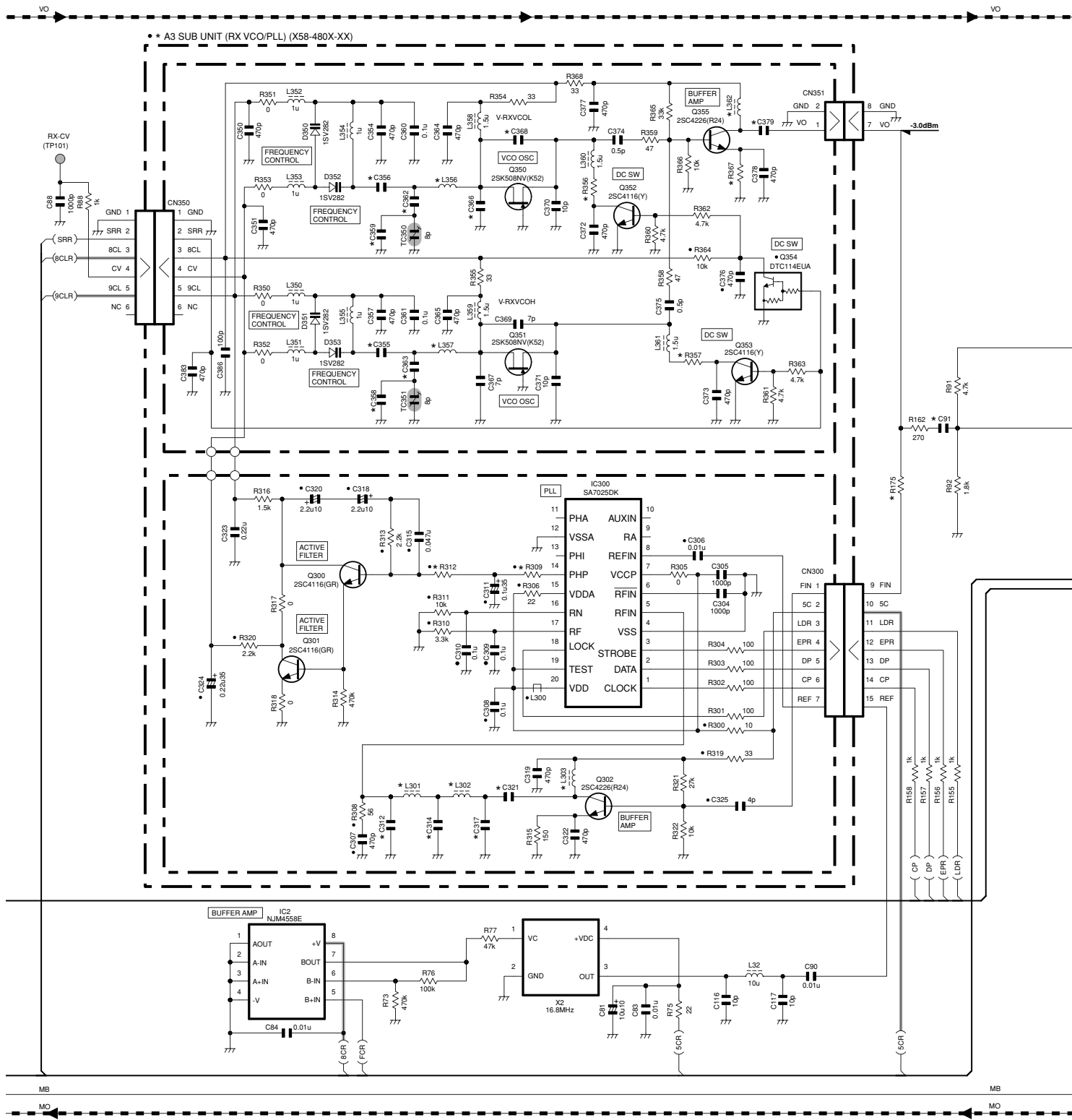


DISPLAY UNIT (X54-3330-21) (B/2)



SCHEMATIC DIAGRAM / 原理图 TKR-850

TX-RX UNIT (X57-696X-XX) (A/2)



A3 SUB UNIT (RX VCO/PLL)

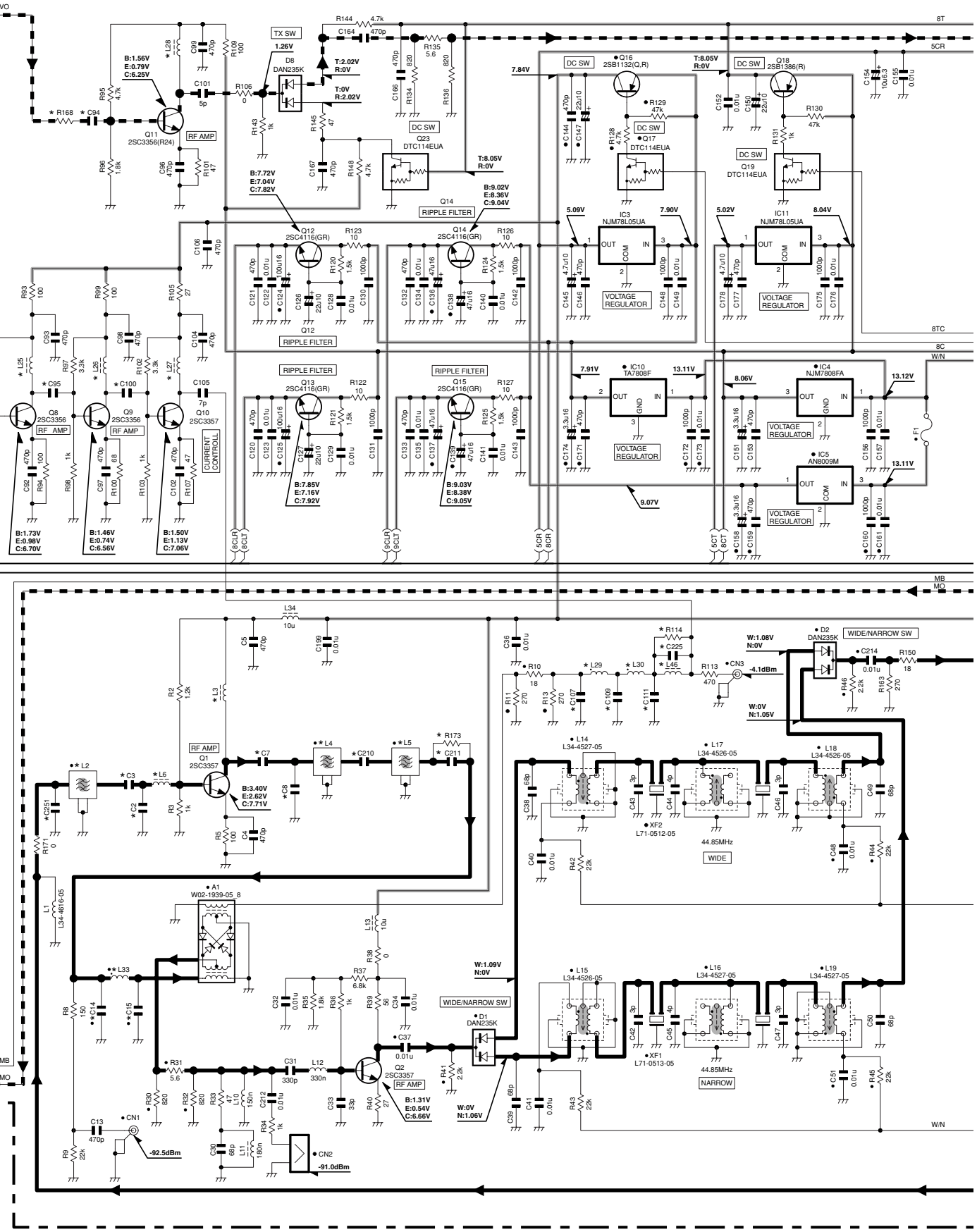
	X58-480X-XX	C312	C314	C317	C321	C355	C356	C358	C359	C362	C363	C366	C368	C379	L301	L302	L303	L356	L357	L362	R309	R312	R356	R357	R367
0-10	C	7p	12p	7p	4p	5p	6p	1.5p	1.5p	22p	15p	7p	7p	4p	18n	18n	22n	L34-4608-05	L34-4608-05	33n	330	330	220	180	100
0-12	C3	8p	18p	8p	4p	6p	6p	1.5p	1.5p	22p	15p	7p	7p	4p	18n	18n	27n	L34-4609-05	L34-4609-05	33n	330	330	220	180	100
3-01	C6	10p	22p	10p	6p	12p	12p	5p	5p	27p	27p	8p	8p	5p	22n	22n	33n	L34-4609-05	L34-4609-05	39n	220	220	270	270	270

TX-RX UNIT

	X57-696X-XX	A3	C91	R175
0-11	C	X58-4800-10	4P	0
0-13	C3	X58-4800-12	5P	390
3-01	C6	X58-4803-01	4P	330

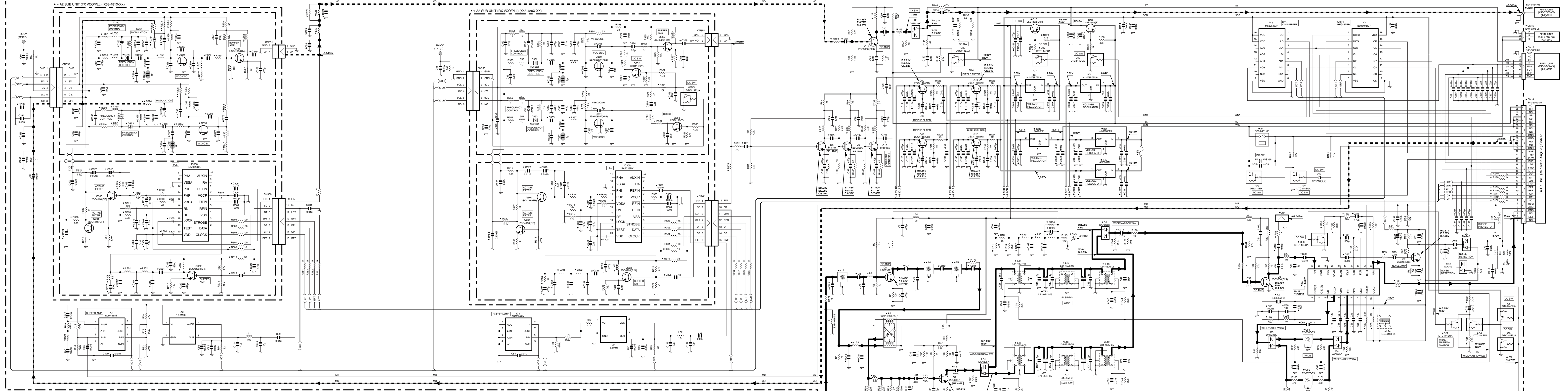
TKR-850 SCHEMATIC DIAGRAM / 原理图

TX-RX UNIT (X57-696X-XX) (A/2)



TX-RX UNIT

X57-696X-XX	C2	C3	C7	C8	C14	C15	C94	C95	C100	C107	C109	C111	C210	C211	C225	C251	L2	L3	L4	L5	L6	L25	L26	L27	L28	L29	L30	L33	L46	R114	R169	R173
0-11	C	NO	12P	12P	0.5P	6P	6P	3P	4P	5P	6P	12P	6P	8P	12P	NO	NO	L79-1849-05	18n	L79-1849-05	L79-1849-05	18n	27n	15n	22n	18n	18n	15n	NO	0	0	NO
0-13	C3	1P	10P	8P	1P	7P	7P	4P	6P	6P	12P	6P	10P	NO	NO	NO	NO	L79-1853-05	15n	L79-1853-05	L79-1853-05	22n	27n	22n	22n	22n	22n	22n	NO	0	270	0
3-01	C6	2P	9P	12P	3P	7P	7P	5P	6P	7P	8P	18P	8P	12P	NO	2P	3P	L79-1851-05	22n	L79-1851-05	L79-1851-05	22n	33n	33n	27n	27n	22n	18n	15n	NO	180	0



A2 SUB UNIT (TX VCO/PLL) (X58-481X-XX) Pinout Table:

Pin	Symbol	Function
0-10	C	0
0-12	C3	7p
3-01	C6	8p

A2 SUB UNIT (TX VCO/PLL) (X58-481X-XX) Pinout Table:

Pin	Symbol	Function
0-10	C	0
0-12	C3	0
3-01	C6	0

A2 SUB UNIT (TX VCO/PLL) (X58-481X-XX) Pinout Table:

Pin	Symbol	Function
0-10	C	0
0-12	C3	0
3-01	C6	0

A3 SUB UNIT (RX VCO/PLL) (X58-480X-XX) Pinout Table:

Pin	Symbol	Function
0-10	C	7p
0-12	C3	8p
3-01	C6	10p

A3 SUB UNIT (RX VCO/PLL) (X58-480X-XX) Pinout Table:

Pin	Symbol	Function
0-10	C	7p
0-12	C3	8p
3-01	C6	10p

A3 SUB UNIT (RX VCO/PLL) (X58-480X-XX) Pinout Table:

Pin	Symbol	Function
0-10	C	7p
0-12	C3	8p
3-01	C6	10p

TX-RX UNIT (X57-696X-XX) Pinout Table:

Pin	Symbol	Function
0-11	C	NO
0-13	C3	1P
3-01	C6	2P

TX-RX UNIT (X57-696X-XX) Pinout Table:

Pin	Symbol	Function
0-11	C	NO
0-13	C3	1P
3-01	C6	2P

TX-RX UNIT (X57-696X-XX) Pinout Table:

Pin	Symbol	Function
0-11	C	NO
0-13	C3	1P
3-01	C6	2P

TX-RX UNIT (X57-696X-XX)(B2)-CN602 Pinout Table:

Pin	Symbol	Function
0-11	C	NO
0-13	C3	1P
3-01	C6	2P

TX-RX UNIT (X57-696X-XX)(B2)-CN602 Pinout Table:

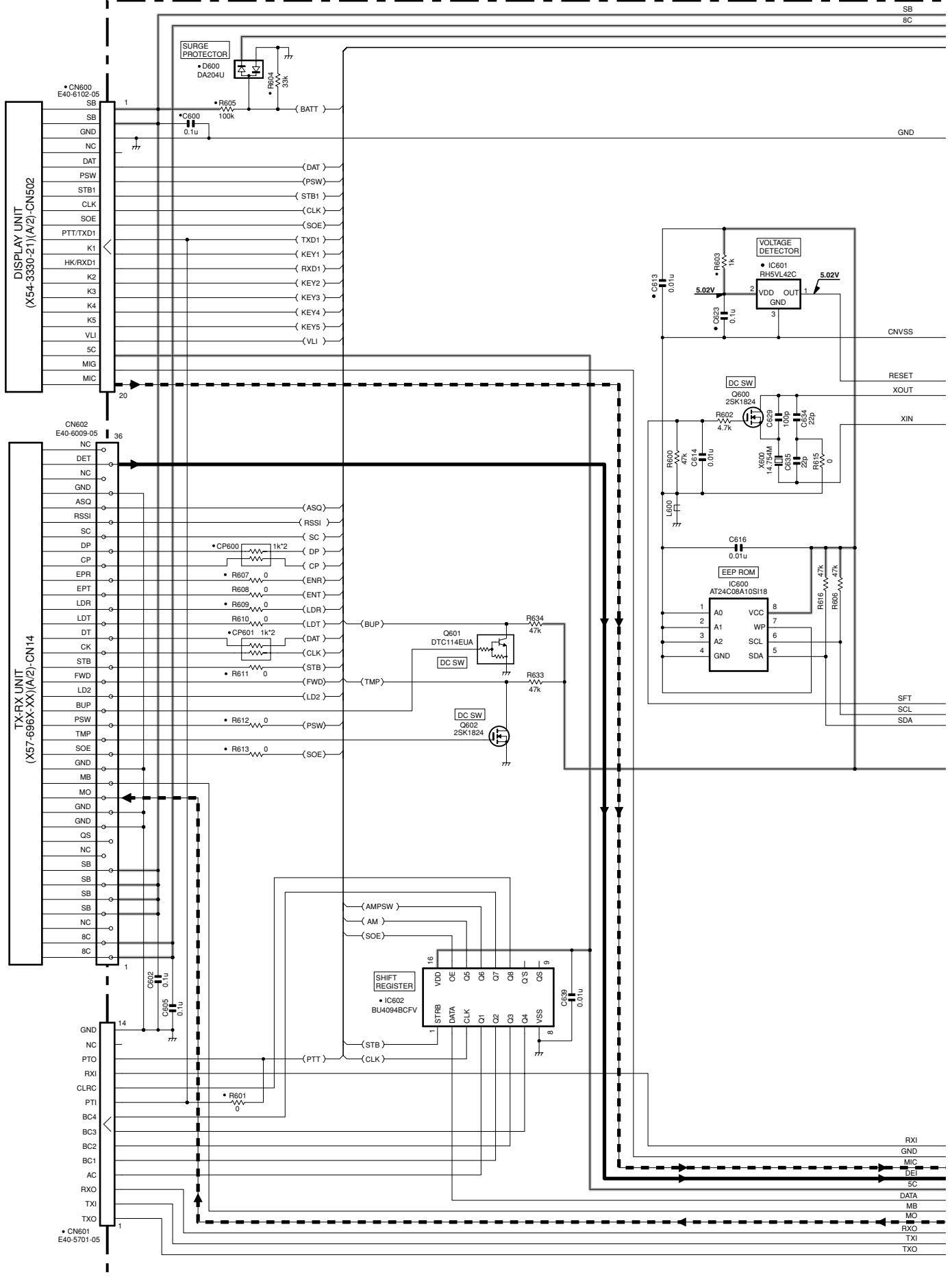
Pin	Symbol	Function
0-11	C	NO
0-13	C3	1P
3-01	C6	2P

TX-RX UNIT (X57-696X-XX)(B2)-CN602 Pinout Table:

Pin	Symbol	Function
0-11	C	NO
0-13	C3	1P
3-01	C6	2P

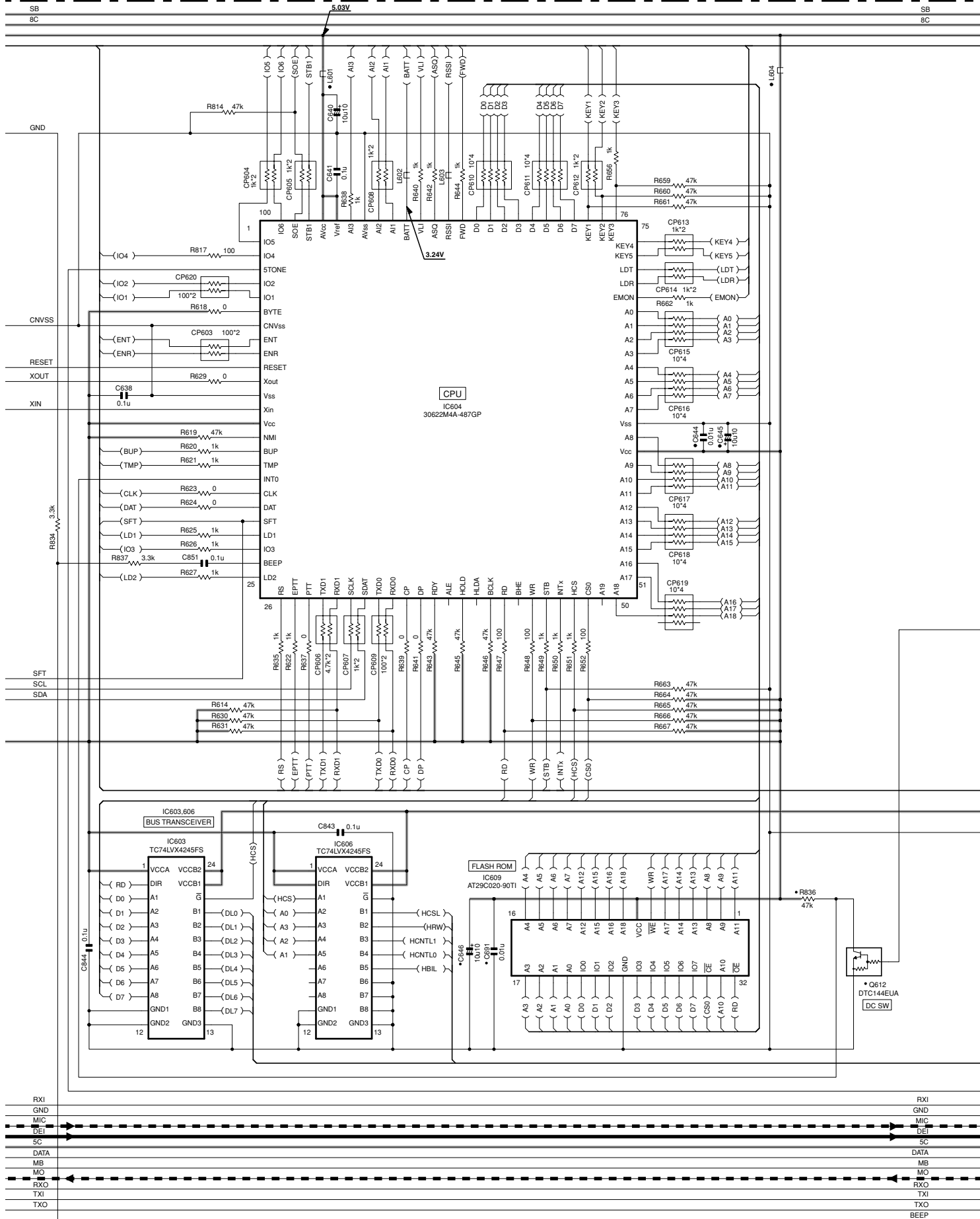
TKR-850 SCHEMATIC DIAGRAM / 原理图

TX-RX UNIT (X57-696X-XX) (B/2)



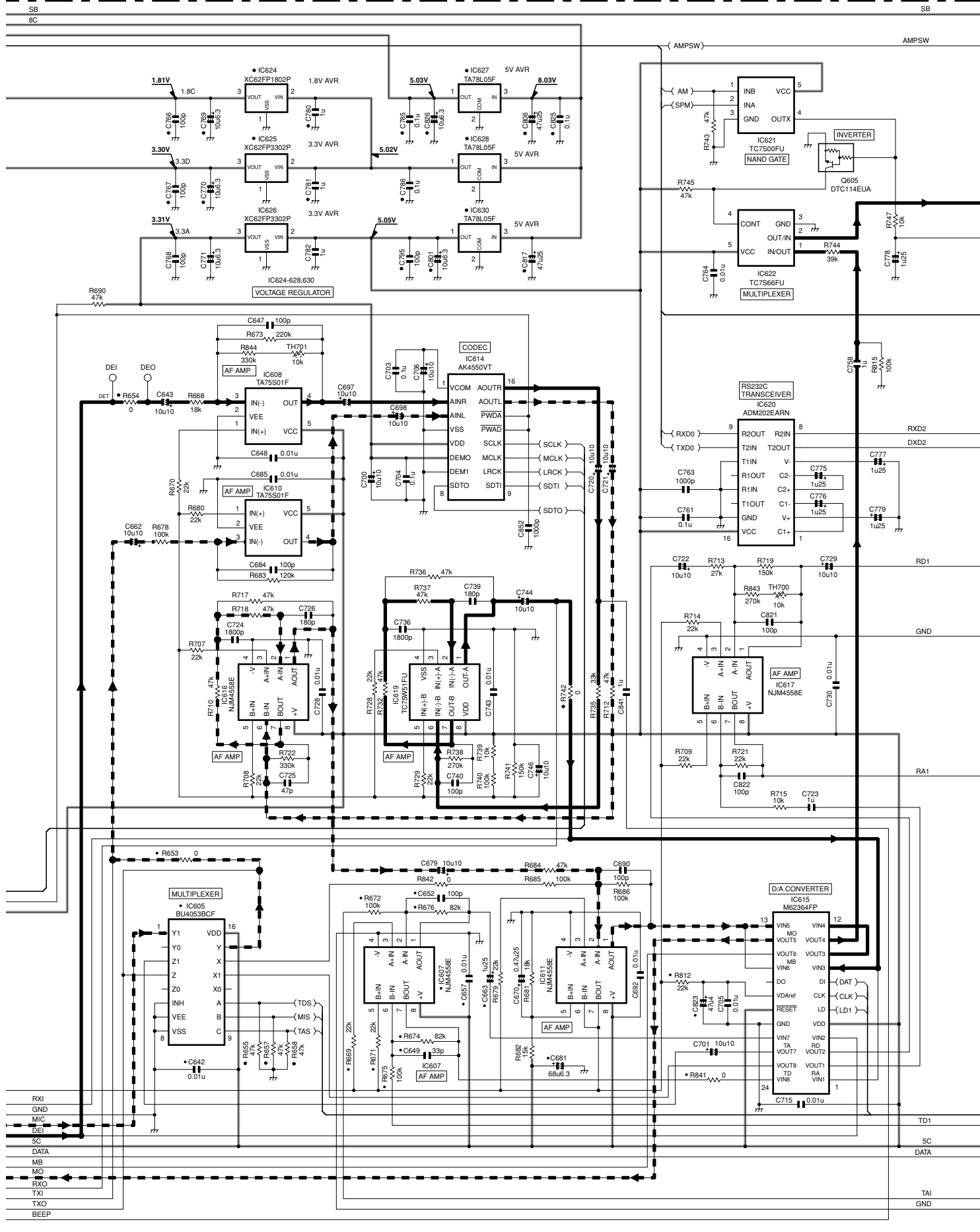
SCHEMATIC DIAGRAM / 原理图 TKR-850

TX-RX UNIT (X57-696X-XX) (B/2)



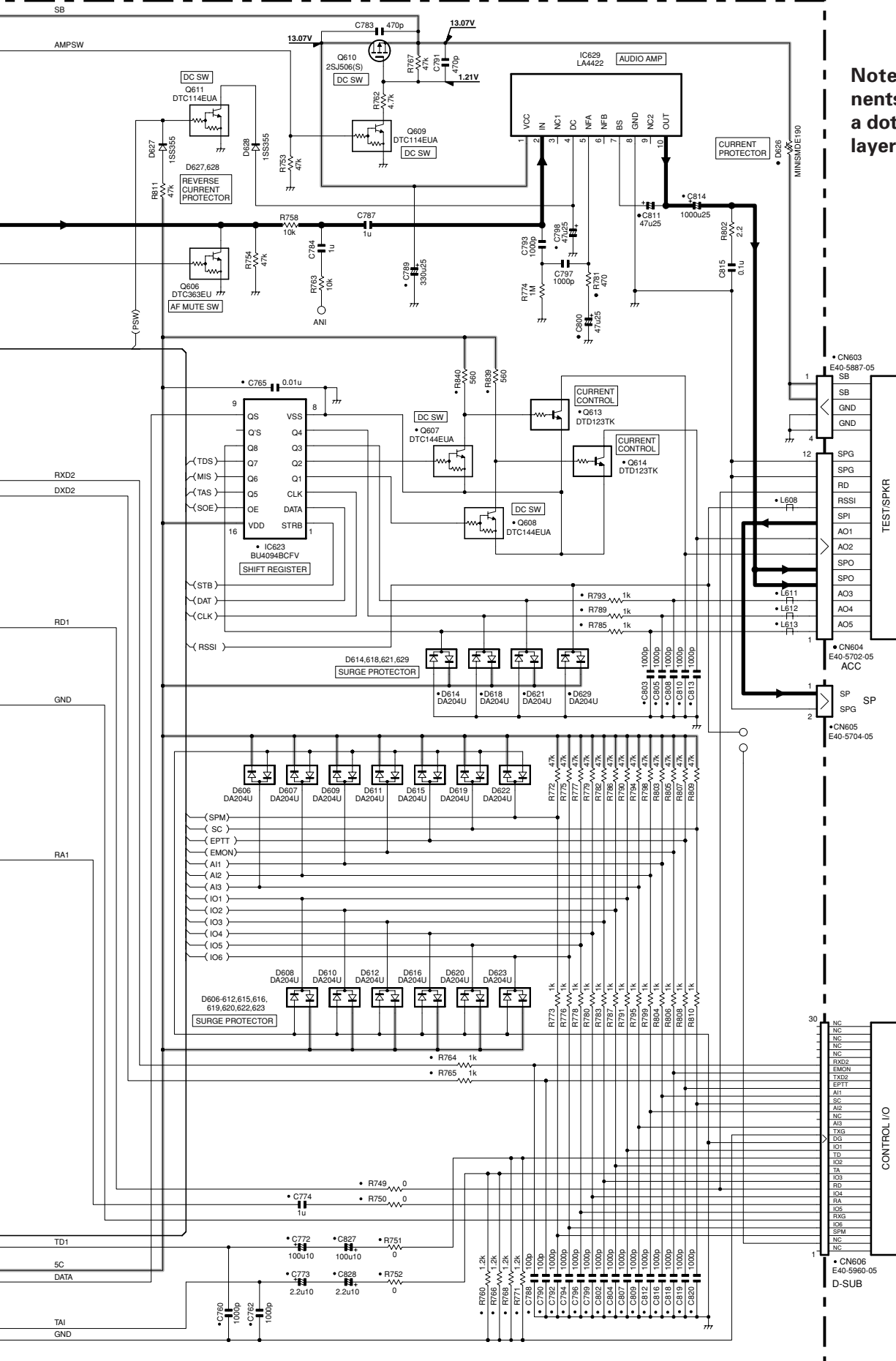
SCHEMATIC DIAGRAM / 原理图 TKR-850

TX-RX UNIT (X57-696X-XX) (B/2)



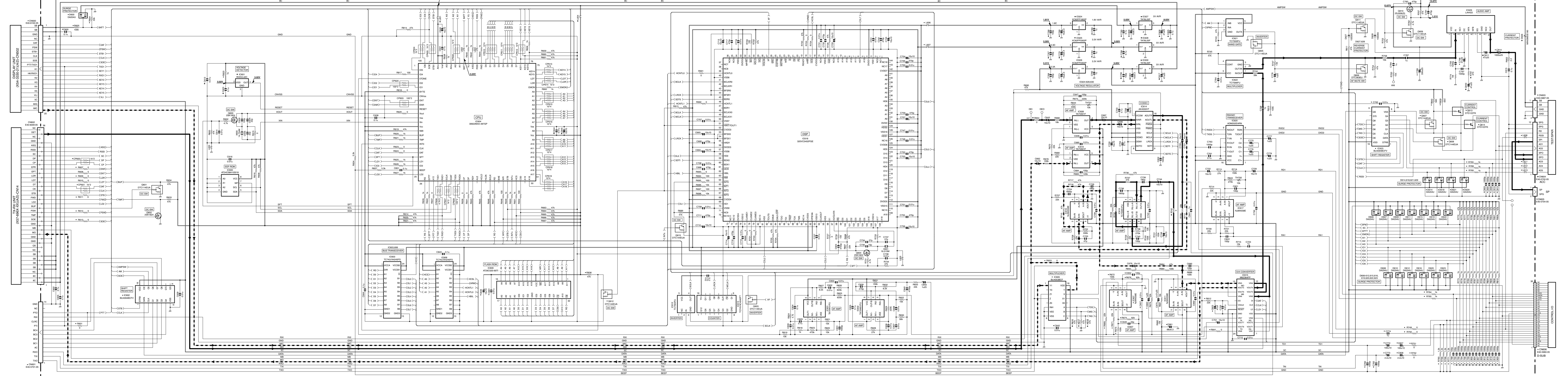
TKR-850 SCHEMATIC DIAGRAM / 原理图

TX-RX UNIT (X57-696X-XX) (B/2)



Note : The components marked with a dot (•) are parts of layer 1.

1
2
3
4
5
6
7



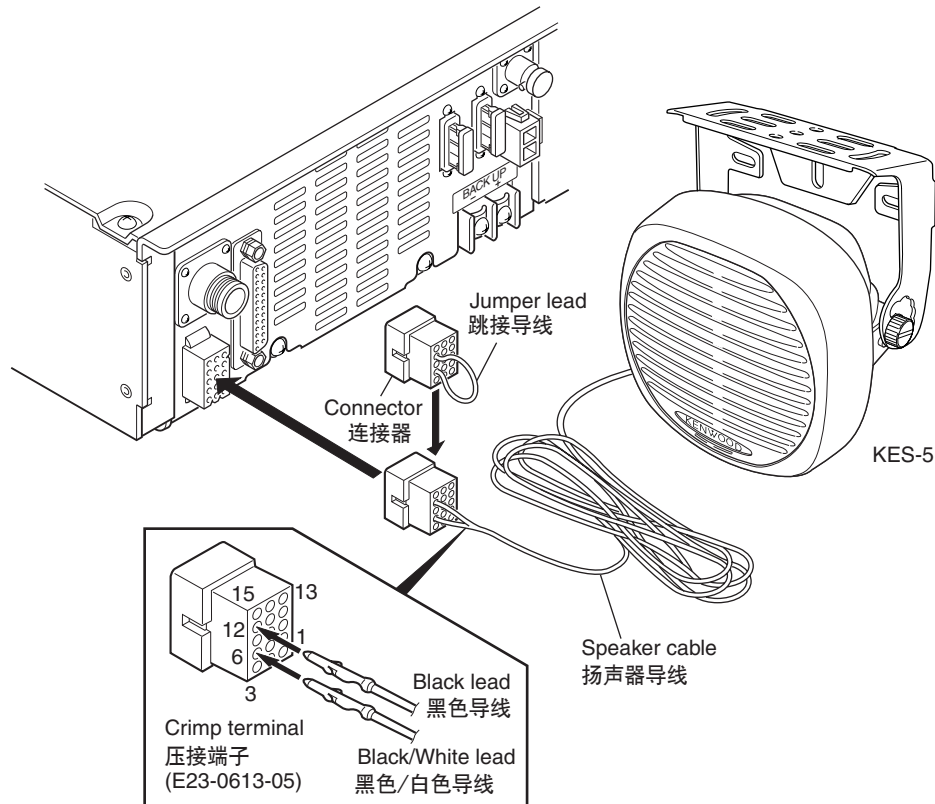
KES-5 (EXTERNAL SPEAKER / 外部扬声器)

When Using an External Speaker

1. Make sure the unit's power is tuned off.
2. When using the external speaker, remove the jumper lead from the connector, and attach the speaker cable.
3. When not using the external speaker, replace the jumper lead and insert the connector into the speaker jack (pin9 and 12).

使用外部扬声器时

1. 确认本机的电源已切断。
2. 使用外部扬声器时, 从连接器上拆除跳接导线, 连接扬声器导线。
3. 不使用外部扬声器时, 恢复跳接导线, 并且将连接器插入扬声器插座。(插脚9和12)



Specifications

Maximum input power	40W
Impedance	4Ω
Dimensions (W x H x D)	129 x 129 x 77 mm
projection not included	5-1/16 x 5-1/16 x 3 inches
Weight	820g / 1.81 lbs

规格

最大输入功率	20W
阻 抗	4Ω
尺寸 (宽 × 高 × 深)	129 × 129 × 77 mm
不包括突出部分	5-1/16" × 5-1/16" × 3"
量 重	820g (1.81磅)

SPECIFICATIONS

GENERAL

Frequency Range	C : 450 to 480MHz	C3 : 400 to 430MHz	C6 : 350 to 390MHz
Number of Channels	16 channel		
Channel Spacing	Wide : 25kHz Narrow : 12.5kHz (PLL channel stepping 5kHz/6.25kHz)		
Operating Voltage	13.6V DC±15%		
Current Drain			
Standby	0.8A		
Standby w/power save	0.3A (Operating mode DC-IN : Backup, FAN : Temp, SAVE : ON, DISP : OFF)		
Receive	1.2A		
Transmit/Receive	Less than 13A		
Duty Cycle			
Receive	100%		
Transmit	100% (100% @25W)		
Frequency Stability	Less than ±0.00015% -30°C to +60°C (-22°F to +140°F)		
Antenna Impedance	50Ω		
Operating Temperature Range	-30°C to +60°C (-22°F to +140°F)		
Dimensions	483 W x 88 H x 340 D mm		
Weight	9.7kg		

RECEIVER (Measured by TIA/EIA-603)

Sensitivity		
12dB SINAD	0.35μV	
20dB Quieting	0.45μV	
Selectivity	Wide : 83dB (±25kHz)	Narrow : 75dB (12.5kHz)
Intermodulation	Wide : 78dB (±25kHz/±50kHz)	Narrow : 75dB (±12.5kHz/±25kHz)
Hum and Noise	Wide : 50dB	Narrow : 45dB
Spurious & Image Rejection	90dB	
Audio Output (Ext. Speaker)	4W at 4Ω less than 5% distortion	
Audio Distortion (Ext. Speaker)	Less than 2.5% at 1000Hz	
Band Spread	5MHz	

TRANSMITTER (Measured by TIA/EIA-603)

RF Power Output	40W adjustable to 25W (100% duty @25W)	
Type of Emission	Wide : 16K0F3E	Narrow : 11K0F3E
Spurious Response	Harmonics : 80dB	Others : 75dB
FM Hum and Noise	Wide : 50dB	Narrow : 45dB
Audio Distortion	Less than 3% at 1000Hz	
Microphone Impedance	600Ω	
Band Spread	30MHz	

规 格

概 述

频率范围	C : 450 ~ 480MHz	C3 : 400 ~ 430MHz	C6 : 350 ~ 390MHz
信道数量	16个信道		
信道间距	宽 : 25kHz 窄 : 12.5kHz (锁相环电路步进频率5kHz/6.25kHz)		
工作电压	13.6V DC \pm 15%		
电流消耗			
备用时	0.8A		
备用时/省电	0.3A (操作模式 DC-IN : 备用, FAN : 温度, 省电 : 打开, 显示 : 关闭)		
接收时	1.2A		
发射时/接收时	低于13A		
工作循环			
接收时	100%		
发射时	100% (100%在25W)		
频率稳定性	低于 \pm 0.00015% - 30°C到 + 60°C		
天线阻抗	50 Ω		
工作温度范围	- 30°C到 + 60°C		
尺 寸	483宽 \times 88高 \times 340长 毫米		
重 量	9.7kg		

接收部 (以每TIA/EIA-603进行测量)

灵敏度

12dB SIBAD	0.35 μ V	
20dB Quieting	0.45 μ V	
选 择 性	宽 : 83dB (\pm 25kHz)	窄 : 75dB (\pm 12.5kHz)
互 调	宽 : 78dB (\pm 25/50kHz)	窄 : 75dB (\pm 12.5/25kHz)
信号对剩余输出功率比	宽 : 50dB	窄 : 45dB
假信号响应	90dB	
音频功率输出 (外部扬声器)	4 Ω 时4W, 失真低于5%	
音频失真 (外部扬声器)	在1000Hz时低于2.5%	
信道频率扩展	5MHz	

发射部 (以每TIA/EIA-603进行测量)

射频功率输出	40W ~ 25W可调 (连续发射25W)	
调 制	宽 : 16K0F3E	窄 : 8K50F3E
寄生谐波	谐波 : 80dB	其他 : 75dB
频率调整噪音	宽 : 50dB	窄 : 45dB
音频失真	在1000Hz时低于3%	
麦克风阻抗	600 Ω	
信道频率扩展	30MHz	

TKR-850

KENWOOD CORPORATION

2967-3, Ishikawa-machi, Hachioji-shi, Tokyo, 192-8525 Japan

KENWOOD U.S.A. CORPORATION

P.O. BOX 22745, 2201 East Dominguez Street, Long Beach, CA 90801-5745, U.S.A.

KENWOOD ELECTRONICS CANADA INC.

6070 Kestrel Road, Mississauga, Ontario, Canada L5T 1S8

KENWOOD ELECTRONICS DEUTSCHLAND GMBH

Rembrücker Str. 15, 63150 Heusenstamm, Germany

KENWOOD ELECTRONICS BELGIUM N.V.

Leuvensesteenweg 248 J, 1800 Vilvoorde, Belgium

KENWOOD ELECTRONICS FRANCE S.A.

13, Boulevard Ney, 75018 Paris, France

KENWOOD ELECTRONICS U.K. LIMITED

KENWOOD House, Dwight Road, Watford, Herts., WD18 9EB United Kingdom

KENWOOD ELECTRONICS EUROPE B.V.

Amsterdamseweg 37, 1422 AC Uithoorn, The Netherlands

KENWOOD ELECTRONICS ITALIA S.p.A.

Via G. Sirtori, 7/9 20129 Milano, Italy

KENWOOD IBERICA S.A.

Bolivia, 239-08020 Barcelona, Spain

KENWOOD ELECTRONICS AUSTRALIA PTY. LTD.

(A.C.N. 001 499 074)

16 Giffnock Avenue, Centrecourt Estate, North Ryde, N.S.W. 2113 Australia

KENWOOD ELECTRONICS (HONG KONG) LTD.

Unit 3712-3724, Level 37, Tower one Metroplaza, 223 Hing Fong Road, Kwai Fong, N.T., Hong Kong

KENWOOD ELECTRONICS SINGAPORE PTE LTD.

1 Ang Mo Kio Street 63, Singapore 569110

